

ICF-C1200

SERVICE MANUAL

Ver 1.0 2001.03

US Model
AEP Model
E Model
Tourist Model



SPECIFICATIONS

Time display:

North and South America and UK:
12-hour system

Other countries: 24-hour system

Frequency range:

Model for North and South America

Band	Frequency range	Channel step
FM	87.5 - 108 MHz	0.1 MHz
AM	530 - 1 710 kHz	10 kHz
	531 - 1 710 kHz	9 KHz

Model for other countries

Band	Frequency range	Channel step
FM	87.5 - 108 MHz	0.05 MHz
AM	531 - 1 602 kHz	9 kHz
	530 - 1 610 kHz	10 kHz

World model

Band	Frequency range	Channel step
FM	76 - 108 MHz	0.1 MHz
AM	531 - 1 710 kHz	9 kHz
	530 - 1 710 kHz	10 kHz

Speaker:

Approx. 2.8 cm (1 $\frac{1}{8}$ inches) dia. 7.2 Ω

Output:

⌀ (headphones) jack

(\emptyset 3.5 mm, stereo minijack)

Power output:

85 mW (at 10 % harmonic distortion)

Power requirements:

3.0 V DC, two R03 (size AAA)
batteries

Battery Life (EIAJ*) (Approx. hours)

	FM		AM	
	Stereo headphones	Speaker	Stereo headphones	Speaker
Sony alkaline LR03 (size AAA)	47	29	60	34
Sony R03 (size AAA)	21	12	29	16

* Measured value by the standard of EIAJ (Electronic Industries of Association of Japan). The battery life may shorten depending on the operation of the unit.

Dimensions:

Approx. 106.7 \times 63 \times 17.2 mm
(w/h/d)

(Approx. 4 $\frac{1}{4}$ \times 2 $\frac{1}{2}$ \times 1 $\frac{1}{16}$ inches)
incl. projecting parts and controls

Approx. 107.7 \times 64.2 \times 24.3 mm
(w/h/d)

(Approx. 4 $\frac{1}{4}$ \times 2 $\frac{5}{8}$ \times 3 $\frac{1}{32}$ inches)
with the cover

Mass:

Approx. 87 g (3.1 oz.)

not incl. batteries, the headphones,
and the cover

Approx. 153 g (5.4 oz.)

incl. batteries, the headphones, and
the cover

Accessories supplied

Stereo headphones (1)

Cover (1)

Sony R03 (size AAA) battery (2)

(Tourist model only)

Design and specifications are subject
to change without notice.

FM STEREO/AM PLL
SYNTHESIZED RADIO

TABLE OF CONTENTS

Specifications 1

1. GENERAL 2

2. DISASSEMBLY

2-1. Main Board 3

3. ELECTRICAL ADJUSTMENTS

3-1. Tuner Section 4

4. DIAGRAMS

4-1. Explanation of IC Terminals 6

4-2. Block Diagram 7

4-3. Printed Wiring Boards

– Main Section (1/2) (Side A) – 8

4-4. Printed Wiring Boards

– Main Section (2/2) (Side B) – 9

4-5. Schematic Diagram 10

5. EXPLODED VIEWS

5-1. Main Section 13

6. ELECTRICAL PARTS LIST 14

Notes on chip component replacement

- Never reuse a disconnected chip component.
- Notice that the minus side of a tantalum capacitor may be damaged by heat.

● **UNLEADED SOLDER**

Boards requiring use of unleaded solder are printed with the lead-free mark (LF) indicating the solder contains no lead. (Caution: Some printed circuit boards may not come printed with the lead free mark due to their particular size.)



Unleaded solder has the following characteristics.

- Unleaded solder melts at a temperature about 40°C higher than ordinary solder. Ordinary soldering irons can be used but the iron tip has to be applied to the solder joint for a slightly longer time. Soldering irons using a temperature regulator should be set to about 350°C. Caution: The printed pattern (copper foil) may peel away if the heated tip is applied for too long, so be careful!
- Strong viscosity Unleaded solder is more viscous (sticky, less prone to flow) than ordinary solder so use caution not to let solder bridges occur such as on IC pins, etc.
- Usable with ordinary solder It is best to use only unleaded solder but unleaded solder may also be added to ordinary solder.

**SECTION 1
GENERAL**

LOCATION AND FUNCTION OF CONTROLS

This section is extracted from instruction manual.

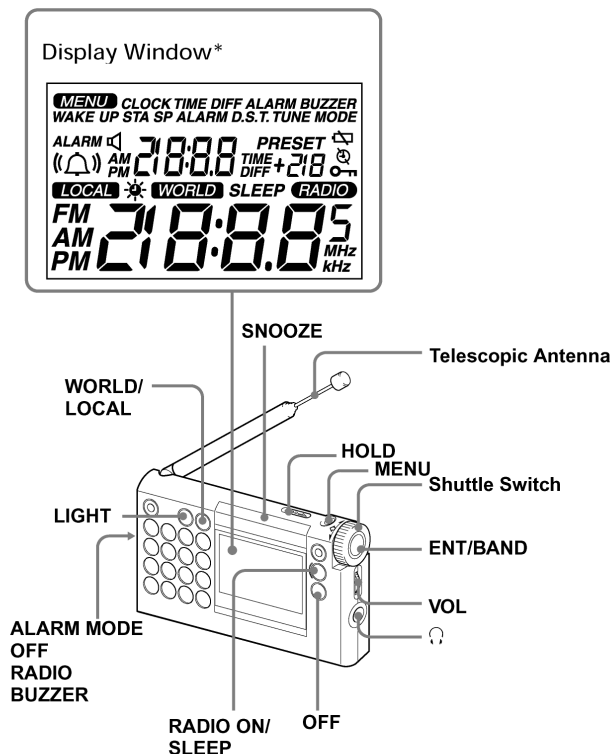

* Part of the display window may differ in some countries.

SECTION 2 DISASSEMBLY

Note : Follow the disassembly procedure in the numerical order given.

2-1. MAIN BOARD

• **Caution during assembly**
Align the hold switch(S301)
to the knob(HOLD).

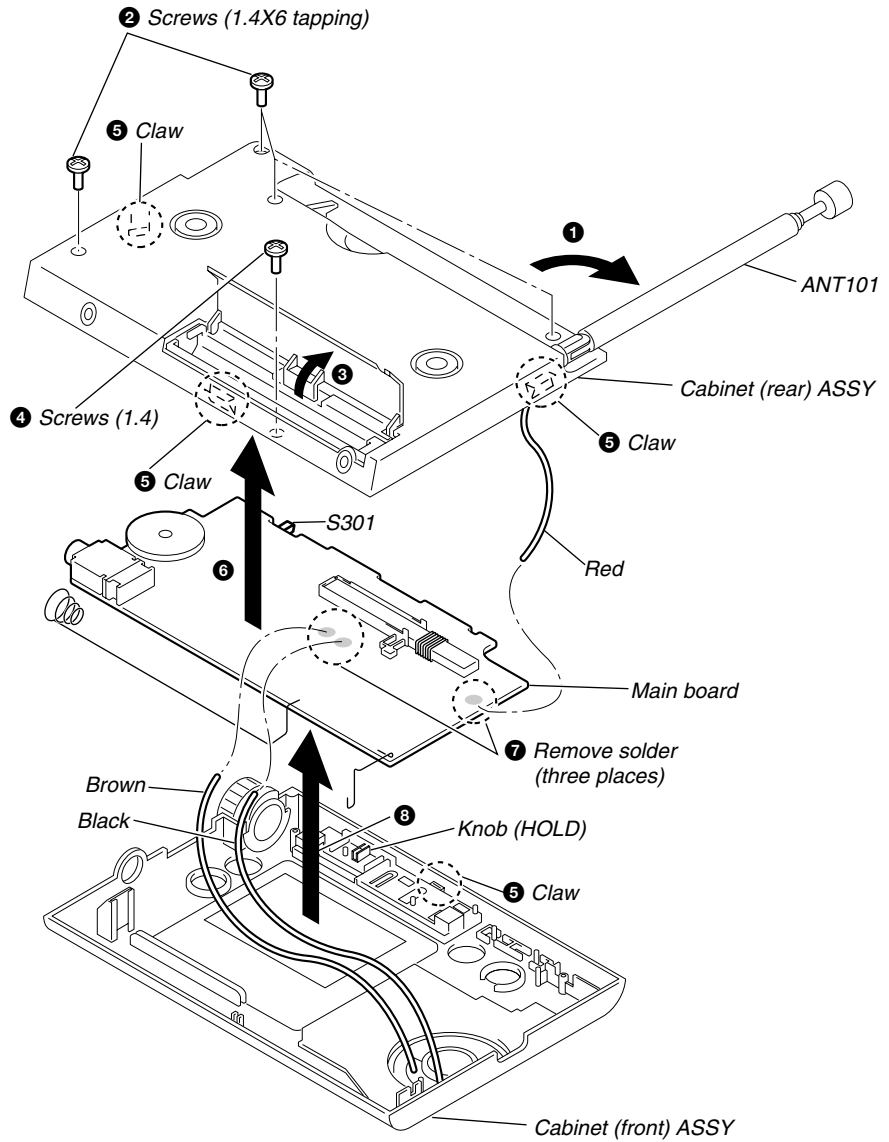

SECTION 3 ELECTRICAL ADJUSTMENTS

3-1. TUNER SECTION

AM Section 0dB=1μV

BAND button : AM
Volume : MIN

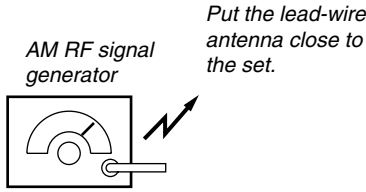

30% amplitude modulation by 400Hz signal.
Output level : as low as possible

FM Section

BAND button : FM
Volume : MIN

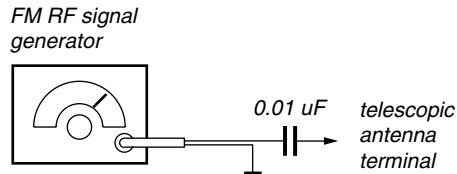

22.5kHz frequency deviation by 400Hz signal.
Output level : as low as possible

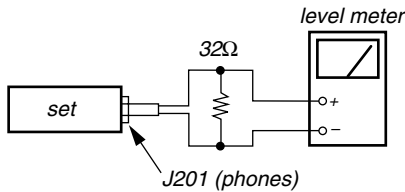

FM FREQUENCY COVERAGE CONFIRMATION		
Adjust part	Frequency display	reading on digital voltmeter
Confirmation	87.5MHz	3.0 to 4.0V
Confirmation	108MHz	9.5 to 10.5V

FM TRACKING ADJUSTMENT	
Adjust for a maximum reading on level meter.	
L103	87.5MHz
CT102	108MHz

Frequency Coverage Adjustment

Connect Location :

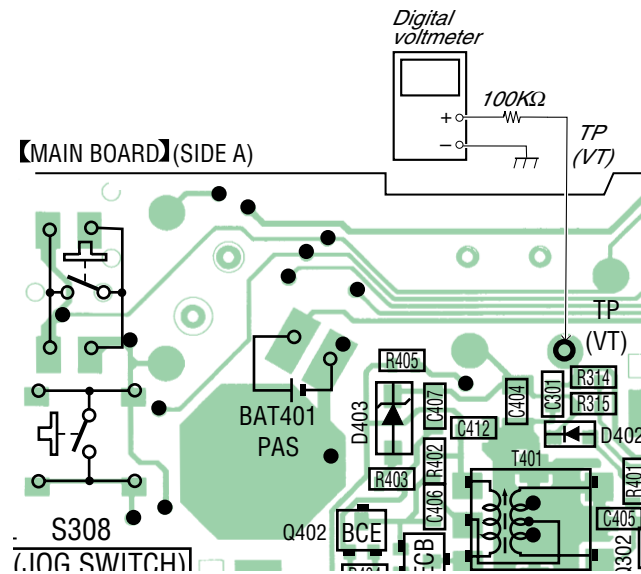

Adjustment Location : Main board (See page 5)

- Repeat the procedures in each adjustment several times, and the frequency coverage and tracking adjustments should be finally done by the trimmer capacitors.

< > : US model

AM IF ADJUSTMENT	
Adjust for a maximum reading on level meter.	
T101	1485kHz <1480kHz>

AM FREQUENCY COVERAGE ADJUSTMENT		
Adjust part	Frequency display	reading on digital voltmeter.
L105	531kHz <530kHz>	Adjustment value: 2.7V Standaed value: 2.5 to 2.9V

AM TRACKING ADJUSTMENT	
Adjust for a maximum reading on level meter.	
L 102	585kHz <580kHz>
CT101	1,485kHz <1,480kHz>

VCO Adjustment

Procedure :

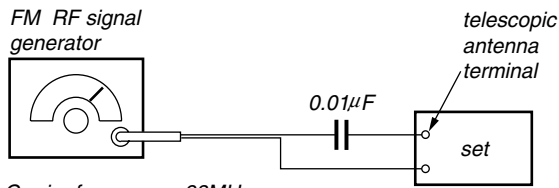

Carrier frequency : 98MHz
 Modulation : No modulation
 Output level : 1.38mV (-55dB)

1. Connect the frequency counter to TP (76k) and TP (3V) as shown the figure below.
2. Turn the set to 98MHz.
3. Adjust RV101 for 76kHz reading frequency counter.
 Standard value:75.5kHz to 76.5kHz.

【MAIN BOARD】(SIDE A)

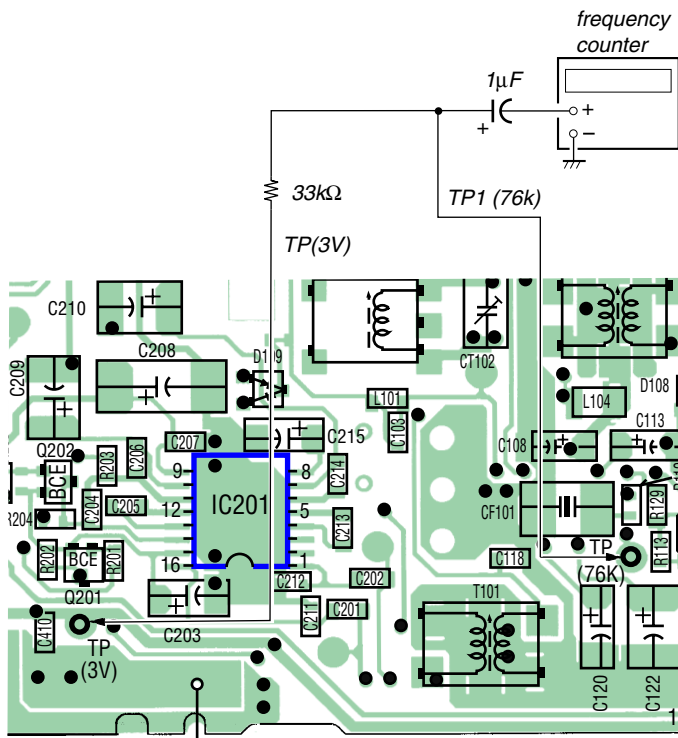

Adjustment Location:

【MAIN BOARD】(SIDE A)

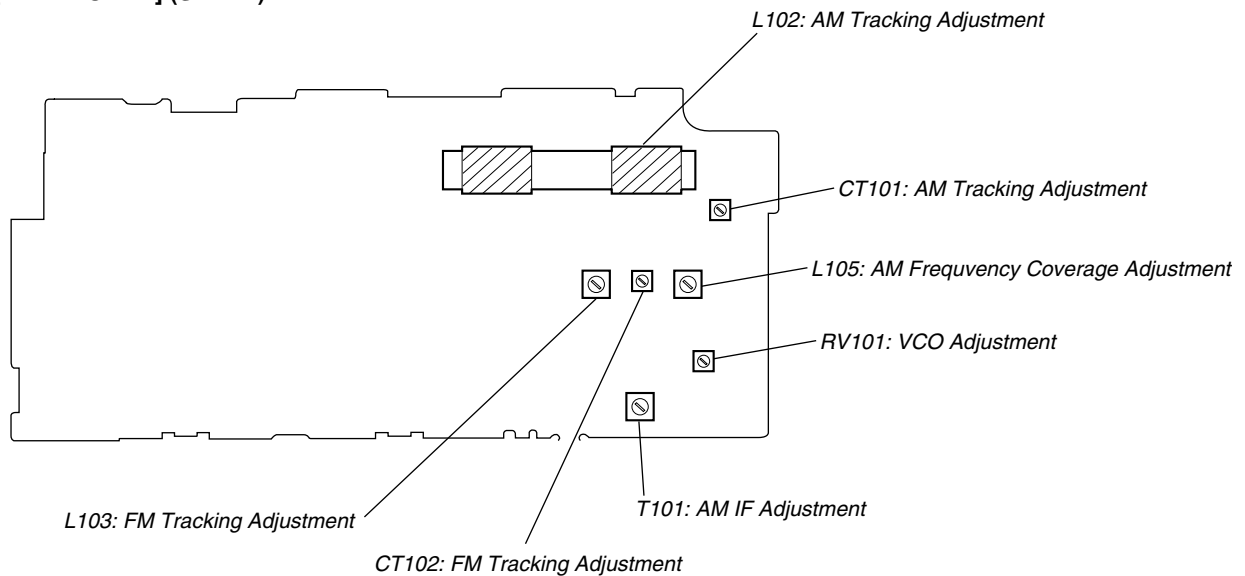

SECTION 4 DIAGRAMS

4-1. EXPLANATION OF IC TERMINALS

• IC301 TC9328AF-SR7491
(System control, LCD driver)

Pin No.	Pin name	I/O	Description
1-4	COM1-4	O	LCD common output.
5-26	S1-S22	O	LCD segment output.
27	HOLD SW	I	HOLD switch input. ON:L OFF:H
28-30	KR1-3	I	Key return input.
31	VDD	—	Power supply terminal.
32-34	KR1-3	O	Key souce output.
35	POWER	O	Power ON control signal output. ON:L OFF:H
36	BEEP	O	Beep signal output.
37	MUTE	O	Mute signal output.
38	WAKE UP	O	Alarm output at volume control min. ON:L OFF:H
39	LCD	I	LCD check test mode setting input.
40	BAND	O	Band select signal output. AM:H FM:L
41	TEST	—	Not used (Fixed at "L").
42	HOLD	—	Not used (Fixed at "L").
43	INTR1	I	1.9V voltage detection terminal. Radio OFF :L
44	INTR2	I	1.1V voltage detection terminal. All OFF :L
45	—	—	Not used (OPEN).
46	—	—	Not used (OPEN).
47	GND	—	Ground terminal.
48	FM IN	I	FM local oscillator signal input.
49	AM IN	I	AM local oscillator signal input.
50	VDD	—	Power supply terminal.
51	D01	—	Not used (OPEN).
52	D02	O	Tuning voltage control output.
53	VREG	—	Regulator output for phase compalator.
54	—	—	Not used (OPEN).
55	AL SW1	I	ALARM switch input (OFF).
56	AL SW2	I	ALARM switch input (RADIO).
57	AL SW3	I	ALARM switch input (BUZZER).
58	VDET	I	2.1V voltage detection input.
59	ID	I	Destination select input.
60	ID	I	Destination select input.
61	—	—	Not used (OPEN).
62	SP BEEP	O	Beep signal output.
63	LIGHT	O	LCD back light ON/OFF output.
64	ST/MO	O	Stereo/Mono select output.
65-69	—	—	Not used (OPEN).
70	RESET	I	Reset signal input.
71	XOUT	O	Oscillator output (75kHz).
72	XIN	I	Oscillator input (75kHz).
73	GND	—	Ground terminal.
74	VDB	—	Capacitor terminal.
75	C1	—	Capacitor terminal.
76	C2	—	Capacitor terminal.
77	VEE	—	Voltage pull-up terminal.
78	C3	—	Capacitor terminal.
79	C4	—	Capacitor terminal.
80	VLCD	—	Voltage pull-up terminal.

4-2. BLOCK DIAGRAMS

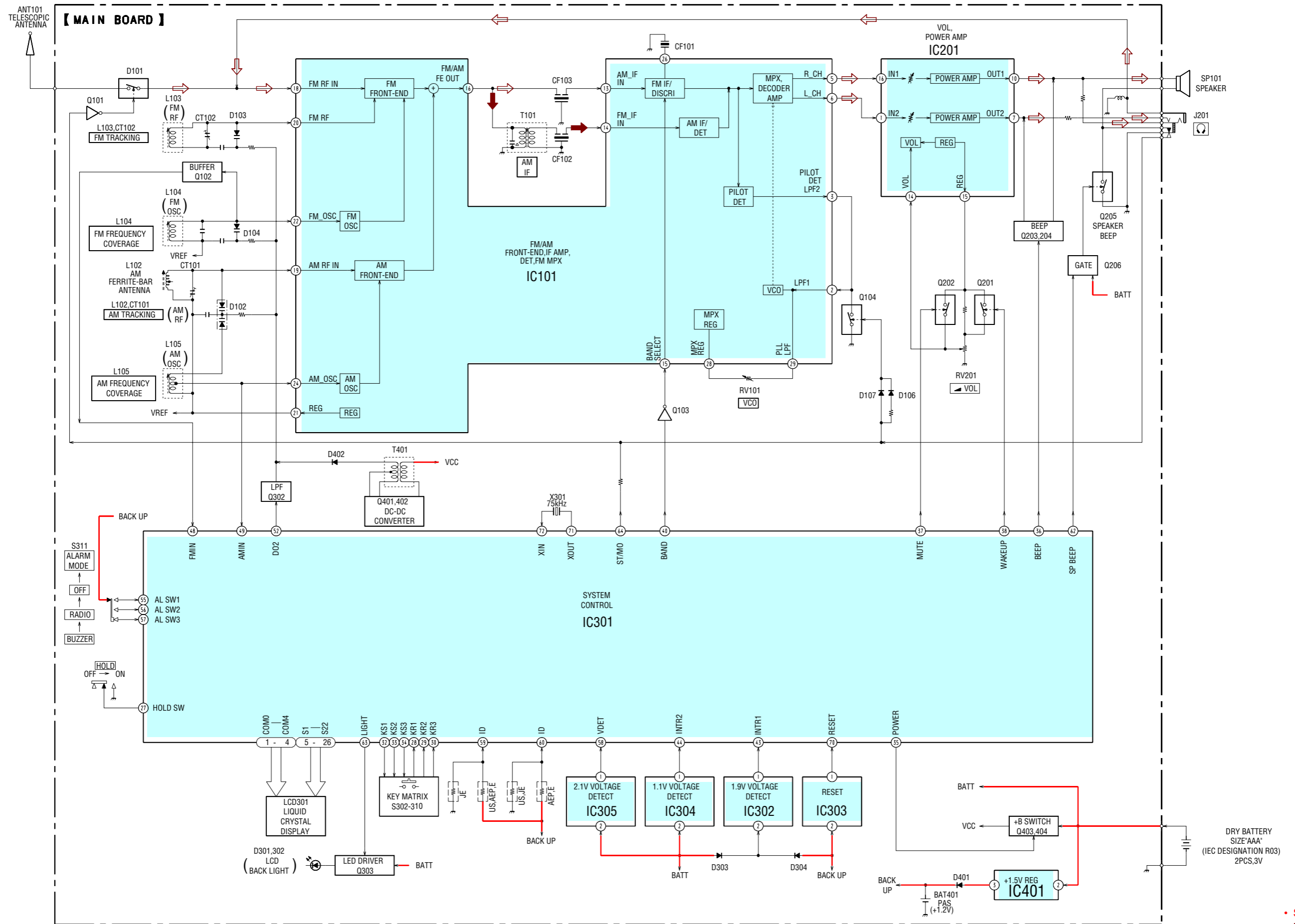

• Signal path.
 : Analog
 : Digital
• Abbreviation
 JE : Tourist

4-3. PRINTED WIRING BOARDS – MAIN SECTION (1/2) (SIDE A) –  : Uses unleaded solder.

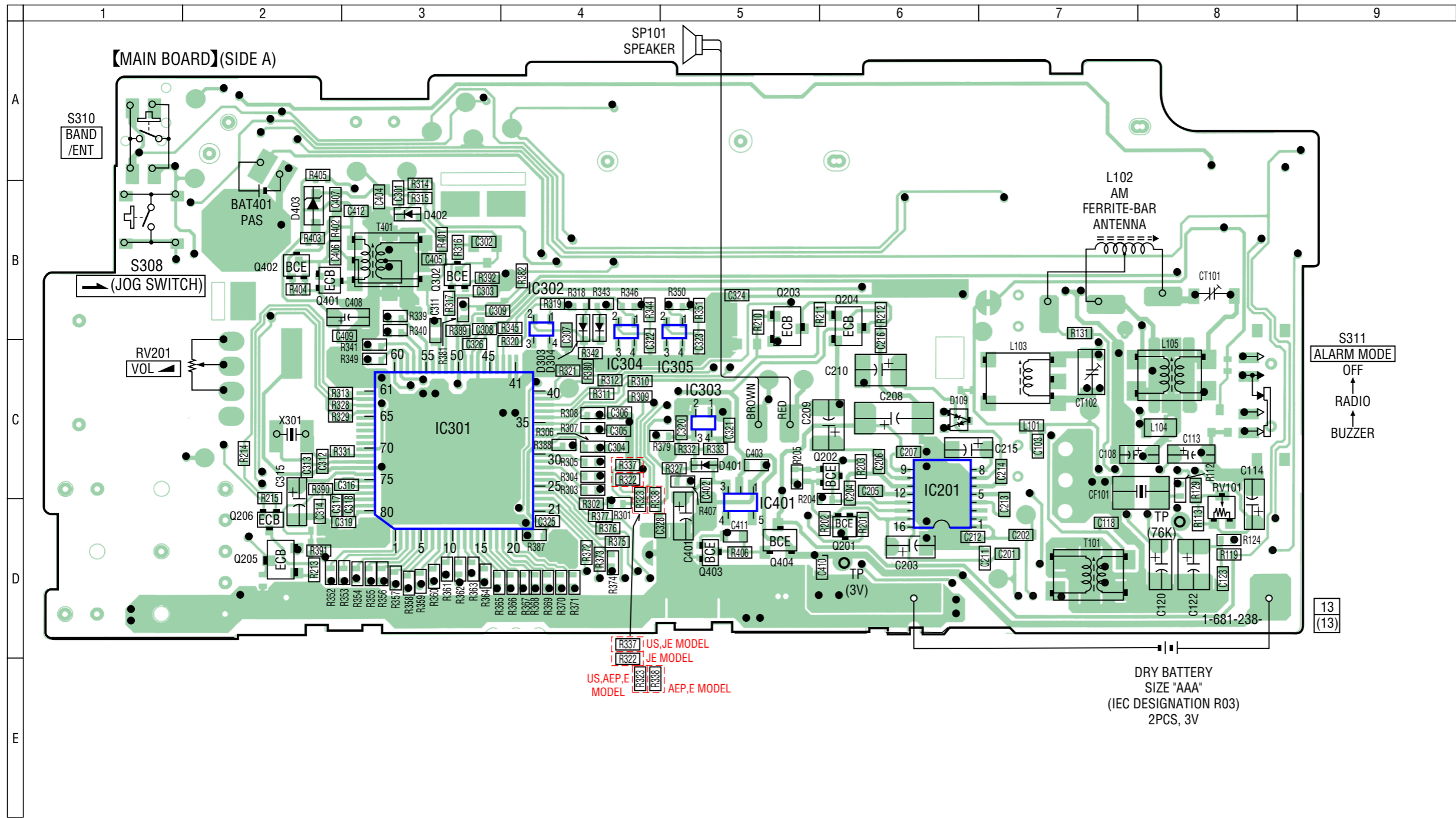

● Semiconductor Location

Ref. No.	Location
D109	C-6
D303	B-4
D304	B-4
D401	C-5
D402	B-3
D403	B-2
IC201	C-6
IC301	C-3
IC302	B-4
IC303	C-5
IC304	B-4
IC305	B-5
IC401	D-5
Q201	D-6
Q202	C-6
Q203	B-5
Q204	B-6
Q205	D-2
Q206	D-2
Q302	B-3
Q401	B-2
Q402	B-2
Q403	D-5
Q404	D-5

R337 US,JE MODEL
 R322 JE MODEL
 US,AEP,E MODEL R338
 R336 AEP,E MODEL

DRY BATTERY
 SIZE "AAA"
 (IEC DESIGNATION R03)
 2PCS, 3V

Note :

- : parts extracted from the component side.
- : Through hole.
- : Pattern from the side which enables seeing. (The other layers' patterns are not indicated.)

Caution:

Pattern face side: (Side B)	Parts on the pattern face side seen from the pattern face are indicated.
Parts face side: (Side A)	Parts on the parts face side seen from the parts face are indicated.

• Abbreviation
 JE : Tourist

4-4. PRINTED WIRING BOARDS – MAIN SECTION (2/2) (SIDE B) –  : Uses unleaded solder.

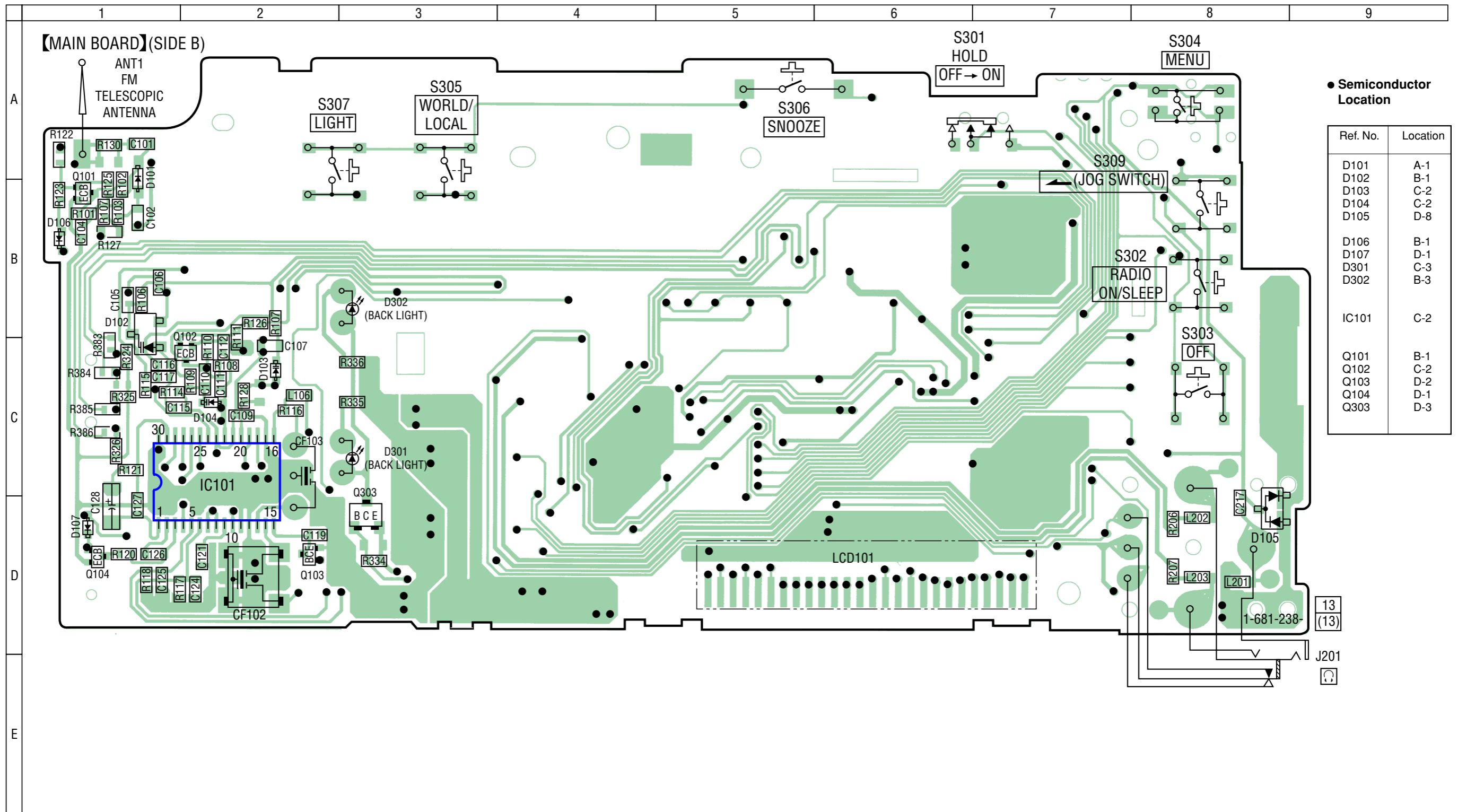

● Semiconductor Location

Ref. No.	Location
D101	A-1
D102	B-1
D103	C-2
D104	C-2
D105	D-8
D106	B-1
D107	D-1
D301	C-3
D302	B-3
IC101	C-2
Q101	B-1
Q102	C-2
Q103	D-2
Q104	D-1
Q303	D-3

Note :

- : parts extracted from the component side.
- : Through hole.
- : Pattern from the side which enables seeing. (The other layers' patterns are not indicated.)

Caution:

Pattern face side: (Side B)	Parts on the pattern face side seen from the pattern face are indicated.
Parts face side: (Side A)	Parts on the parts face side seen from the parts face are indicated.

• Abbreviation
JE : Tourist

Note on Schematic Diagram: MAIN SECTION

- All capacitors are in μF unless otherwise noted. pF: $\mu\mu\text{F}$ 50 WV or less are not indicated except for electrolytics and tantalums.
- All resistors are in Ω and $1/4\text{ W}$ or less unless otherwise specified.
- Δ : internal component.
- : B+ Line.
- : adjustment for repair.
- Power voltage is dc 3V and fed with regulated dc power supply from battery terminal.
- Voltages and waveforms are dc with respect to ground under no-signal (detuned) conditions.
- no mark : FM
- () : AM
- Voltages are taken with a VOM (Input impedance 10 M Ω). Voltage variations may be noted due to normal production tolerances.
- Waveforms are taken with an oscilloscope. Voltage variations may be noted due to normal production tolerances.
- Circled numbers refer to waveforms.
- Signal path.
- \Rightarrow : Analog
- \Rightarrow : Digital
- Abbreviation
- JE : Tourist

• Waveforms

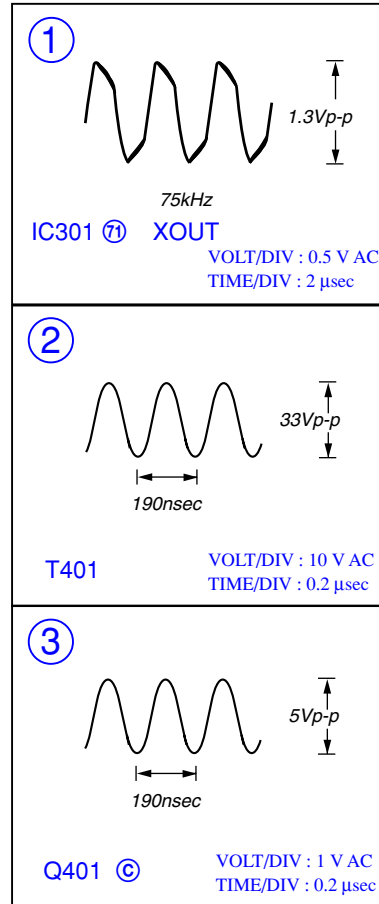

ICF-C1200

• IC BLOCK DIAGRAMS

IC101 CX1238N-T4

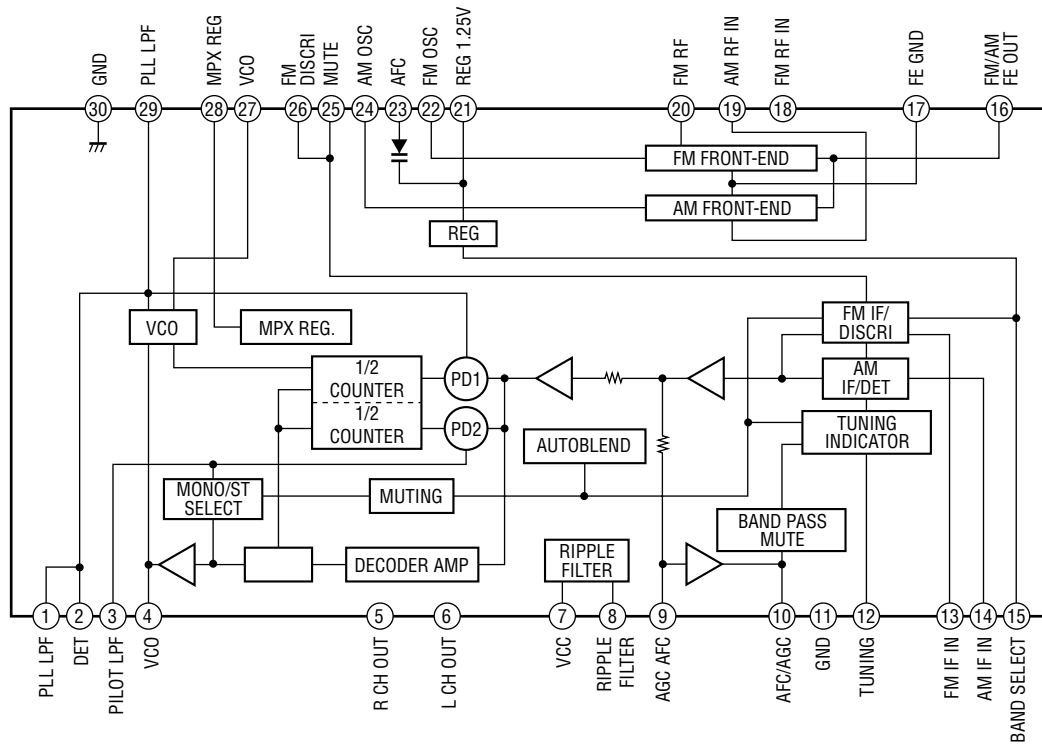

IC201 CXA1522N-T4

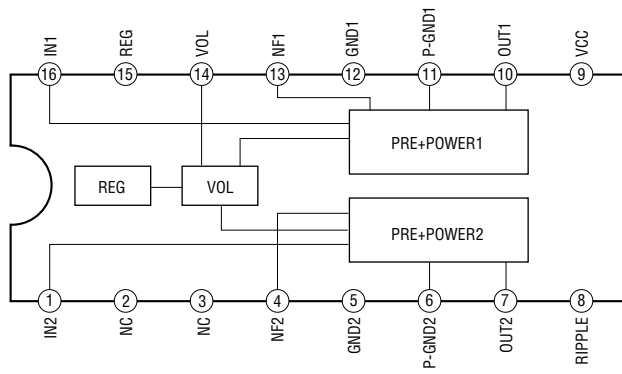

SECTION 5 EXPLODED VIEWS

NOTE :

- -XX, -X mean standardized parts, so they may have some difference from the original one.
- Items marked “ * ” are not stocked since they are seldom required for routine service. Some delay should be anticipated when ordering these items.
- The mechanical parts with no reference number in the exploded views are not supplied.
- Hardware (# mark) list and accessories and packing materials are given in the last of this parts list.
- Abbreviation
JE : Tourist

5-1. MAIN SECTION

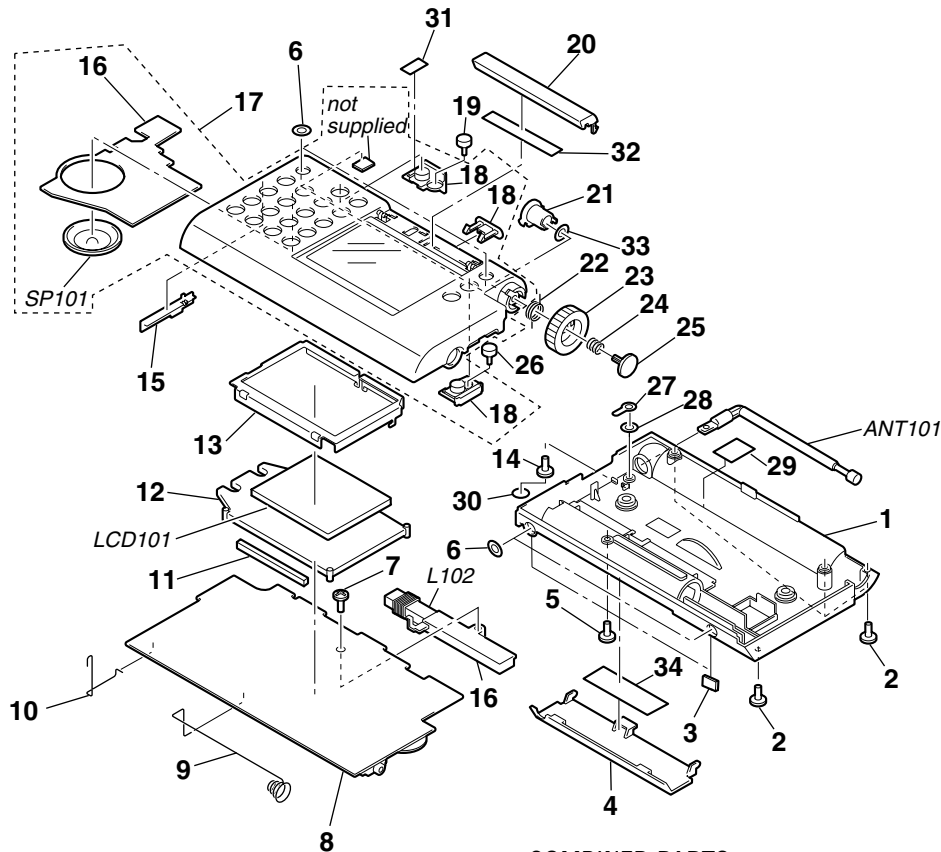

COMBINED PARTS (The order with a single article is not completed)

Ref. No.	Part No.	Description
16	3-229-726-01	HOLDER (COMBINED), HOLDER (SP), HOLDER (ANT)
18	3-229-731-01	BUTTON (COMBINED), KNOB (HOLD), BUTTON (MENU), BUTTON (LIGHT), BUTTON (POWER)

Ref. No.	Part No.	Description	Remark	Ref. No.	Part No.	Description	Remark
1	X-3380-789-1	CABINET,(REAR) ASSY		20	3-229-736-01	BUTTON (SNOOZE)	
2	3-309-597-61	SCREW (1.4X6), TAPPING		21	3-229-740-01	HOLDER (JOG)	
3	3-229-746-01	MAGNET		22	3-229-744-01	SPRING (JOG), TORSION	
4	3-229-729-01	LID, BATTERY CASE		23	3-229-738-01	KNOB (JOG)	
5	3-309-597-31	SCREW (1.4), TAPPING,PRECISION		24	3-229-745-01	SPRING (JOG), COMPRESSION	
6	3-230-045-01	WASHER		25	3-229-737-01	BUTTON (ENTER)	
7	3-309-597-01	SCREW (1.4), TAPPING		26	3-229-739-11	CAP	
* 8	A-3021-421-A	MAIN BOARD, COMPLETE (JE)		27	7-623-505-01	LUG, 2	
* 8	A-3021-422-A	MAIN BOARD, COMPLETE (AEP/E)		28	3-232-666-01	PAPER, ADHESIVE (SECONDARY BATTERY)	
* 8	A-3021-423-A	MAIN BOARD, COMPLETE (US)		29	3-233-522-01	CUSHION (ANT)	
9	3-229-743-01	TERMINAL (-), BATTERY		30	3-232-963-01	SHEET (ANT)	
10	3-229-742-01	TERMINAL (+), BATTERY		31	3-233-521-01	CUSHION (LIGHT)	
11	1-694-596-11	CONDUCTIVE BOARD, CONNECTION		32	3-233-520-01	CUSHION (SNOOZE)	
12	3-229-725-01	HOLDER (LCD)		33	3-232-964-01	SPACER (JOG)	
* 13	3-229-741-01	CASE (LCD), SHIELD		34	3-232-965-01	CUSHION (BATTERY LID)	
14	7-621-771-06	SCREW +B 2X5		ANT101	1-754-183-11	ANTENNA, TELESCOPIC	
15	3-229-730-01	KNOB (ALARM)		L102	1-501-974-41	ANTENNA, FERRITE-BAR (MW) (AM TRACKING)	
17	X-3380-788-1	CABINET,(FRONT) ASSY		LCD101	1-804-341-11	DISPLAY PANEL, LIQUID CRYSTAL	
19	3-229-739-01	CAP		SP101	1-529-187-11	SPEAKER (2.8cm)	

SECTION 6
ELECTRICAL PARTS LIST

NOTE :

- Due to standardization, replacements in the parts list may be different from the parts specified in the diagrams or the components used on the set.
- -XX, -X mean standardized parts, so they may have some difference from the original one.
- RESISTORS
All resistors are in ohms
METAL : Metal-film resistor
METAL OXIDE :Metal oxide-film resistor
F : nonflammable
- Items marked “ * ”are not stocked since they are seldom required for routine service. Some delay should be anticipated when ordering these items.

- SEMICONDUCTORS
In each case, u : μ , for example :
uA.... : μ A.... , uPA.... : μ PA....
uPB.... : μ PB.... , uPC.... : μ PC....
uPD.... : μ PD....
- CAPACITORS
uF : μ F
- COILS
uH : μ H
- Abbreviation
JE : Tourist

Ref. No.	Part No.	Description	Remark	Ref. No.	Part No.	Description	Remark
*	A-3021-421-A	MAIN BOARD, COMPLETE (JE)		C204	1-107-820-11	CERAMIC CHIP 0.1uF	16V
*	A-3021-422-A	MAIN BOARD, COMPLETE (AEP,E)		C205	1-125-837-11	CERAMIC CHIP 1uF	10% 6.3V
*	A-3021-423-A	MAIN BOARD, COMPLETE (US)		C206	1-125-837-91	CERAMIC CHIP 1uF	10% 6.3V
		*****		C207	1-115-156-11	CERAMIC CHIP 1uF	10V
	3-229-726-01	HOLDER (COMBINED)		C208	1-125-899-11	TANTAL. CHIP 220uF	20% 4V
		< BATTERY >		C209	1-127-569-11	TANTAL. CHIP 100uF	20% 4V
BAT401	1-528-412-11	BATTERY, PAS SECONDARY		C210	1-127-569-11	TANTAL. CHIP 100uF	20% 4V
		< CAPACITOR >		C211	1-164-937-11	CERAMIC CHIP 0.001uF	10% 16V
C101	1-115-416-11	CERAMIC CHIP 0.001uF	5% 25V	C212	1-164-937-11	CERAMIC CHIP 0.001uF	10% 16V
C102	1-115-416-11	CERAMIC CHIP 0.001uF	5% 25V	C213	1-125-837-11	CERAMIC CHIP 1uF	10% 6.3V
C103	1-164-844-11	CERAMIC CHIP 4PF	0.25PF 16V	C214	1-125-837-11	CERAMIC CHIP 1uF	10% 6.3V
C104	1-164-943-11	CERAMIC CHIP 0.01uF	10% 16V	C215	1-135-201-11	TANTALUM CHIP 10uF	20% 4V
C105	1-107-819-11	CERAMIC CHIP 0.022uF	16V	C216	1-107-820-11	CERAMIC CHIP 0.1uF	16V
C106	1-164-843-11	CERAMIC CHIP 3PF	0.25PF 16V	C217	1-164-874-11	CERAMIC CHIP 100PF	5% 16V
C107	1-115-416-11	CERAMIC CHIP 0.001uF	5% 25V	C301	1-125-777-11	CERAMIC CHIP 0.1uF	10% 10V
C108	1-104-847-11	TANTAL. CHIP 22uF	20% 4V	C302	1-110-501-11	CERAMIC CHIP 0.33uF	10% 16V
C109	1-164-943-11	CERAMIC CHIP 0.01uF	10% 16V	C303	1-164-937-11	CERAMIC CHIP 0.001uF	10% 16V
C110	1-115-416-11	CERAMIC CHIP 0.001uF	5% 25V	C304	1-164-939-11	CERAMIC CHIP 0.0022uF	10% 16V
C111	1-164-842-11	CERAMIC CHIP 2PF	0.25PF 16V (JE)	C305	1-164-939-11	CERAMIC CHIP 0.0022uF	10% 16V
C111	1-164-850-11	CERAMIC CHIP 10PF	0.50PF 16V (US,AEP,E)	C306	1-164-939-11	CERAMIC CHIP 0.0022uF	10% 16V
C112	1-164-842-11	CERAMIC CHIP 2PF	0.25PF 16V	C307	1-115-156-11	CERAMIC CHIP 1uF	10V
C113	1-135-151-21	TANTALUM CHIP 4.7uF	20% 4V	C308	1-164-937-11	CERAMIC CHIP 0.001uF	10% 16V
C114	1-135-201-11	TANTALUM CHIP 10uF	20% 4V	C309	1-164-943-11	CERAMIC CHIP 0.01uF	10% 16V
C115	1-164-858-11	CERAMIC CHIP 22PF	5% 16V	C311	1-117-863-11	CERAMIC CHIP 0.47uF	10% 6.3V
C116	1-164-930-11	CERAMIC CHIP 330PF	5% 16V	C312	1-164-854-11	CERAMIC CHIP 15PF	5% 16V
C117	1-164-872-11	CERAMIC CHIP 82PF	5% 16V	C313	1-164-850-11	CERAMIC CHIP 10PF	0.50PF 16V
C118	1-164-315-11	CERAMIC CHIP 470PF	5% 50V	C314	1-125-777-11	CERAMIC CHIP 0.1uF	10% 10V
C119	1-164-943-11	CERAMIC CHIP 0.01uF	10% 16V	C315	1-135-201-11	TANTALUM CHIP 10uF	20% 4V
C120	1-135-201-11	TANTALUM CHIP 10uF	20% 4V	C316	1-125-777-11	CERAMIC CHIP 0.1uF	10% 10V
C121	1-115-156-11	CERAMIC CHIP 1uF	10V	C317	1-125-777-11	CERAMIC CHIP 0.1uF	10% 10V
C122	1-127-569-11	TANTAL. CHIP 100uF	20% 4V	C318	1-125-777-11	CERAMIC CHIP 0.1uF	10% 10V
C123	1-115-156-11	CERAMIC CHIP 1uF	10V	C319	1-125-777-11	CERAMIC CHIP 0.1uF	10% 10V
C124	1-164-677-11	CERAMIC CHIP 0.033uF	10% 16V	C320	1-164-943-11	CERAMIC CHIP 0.01uF	10% 16V
C125	1-164-677-11	CERAMIC CHIP 0.033uF	10% 16V	C321	1-107-820-11	CERAMIC CHIP 0.1uF	16V
C126	1-115-156-11	CERAMIC CHIP 1uF	10V	C322	1-107-820-11	CERAMIC CHIP 0.1uF	16V
C127	1-113-619-11	CERAMIC CHIP 0.47uF	10V	C323	1-107-820-11	CERAMIC CHIP 0.1uF	16V
C128	1-135-151-21	TANTALUM CHIP 4.7uF	20% 4V	C324	1-164-937-11	CERAMIC CHIP 0.001uF	10% 16V
C201	1-115-156-11	CERAMIC CHIP 1uF	10V	C325	1-164-943-11	CERAMIC CHIP 0.01uF	10% 16V
C202	1-115-156-11	CERAMIC CHIP 1uF	10V	C326	1-164-943-11	CERAMIC CHIP 0.01uF	10% 16V
C203	1-135-201-11	TANTALUM CHIP 10uF	20% 4V	C328	1-125-777-11	CERAMIC CHIP 0.1uF	10% 10V
				C401	1-135-201-11	TANTALUM CHIP 10uF	20% 4V
				C402	1-164-937-11	CERAMIC CHIP 0.001uF	10% 16V
				C403	1-115-156-11	CERAMIC CHIP 1uF	10V

Ref. No.	Part No.	Description	Remark	Ref. No.	Part No.	Description	Remark
C404	1-164-346-11	CERAMIC CHIP 1uF	16V	L104	1-414-693-11	INDUCTOR 150nH	
C405	1-164-850-11	CERAMIC CHIP 10PF	0.50PF 16V			(FM FREQUENCY COVERAGE) (JE)	
C406	1-164-850-11	CERAMIC CHIP 10PF	0.50PF 16V	L104	1-414-690-21	INDUCTOR 82nH	
C407	1-107-826-11	CERAMIC CHIP 0.1uF	10% 16V			(FM FREQUENCY COVERAGE)(US,AEP,E)	
C408	1-135-201-11	TANTALUM CHIP 10uF	20% 4V	L105	1-406-258-21	COIL (OSC) (AM FREQUENCY COVERAGE)	
C409	1-107-820-11	CERAMIC CHIP 0.1uF	16V	L106	1-412-987-31	INDUCTOR 4.7uH	
C410	1-115-156-11	CERAMIC CHIP 1uF	10V	L201	1-412-987-31	INDUCTOR 4.7uH	
C411	1-115-156-11	CERAMIC CHIP 1uF	10V	L202	1-412-987-31	INDUCTOR 4.7uH	
C412	1-107-820-11	CERAMIC CHIP 0.1uF	16V	L203	1-412-987-31	INDUCTOR 4.7uH	
		< FILTER >				< LIQUID CRYSTAL DISPLAY >	
CF101	1-795-252-21	DISCRIMINATOR, CERAMIC		LCD101	1-804-341-11	DISPLAY PANEL, LIQUID CRYSTAL	
CF102	1-767-480-11	FILTER, CERAMIC (AM)				< TRANSISTOR >	
CF103	1-577-588-11	FILTER, CERAMIC					
		< TRIMMER >		Q101	8-729-037-92	TRANSISTOR 2SD2216J-R(TX).SO	
CT101	1-141-615-21	CAP, ADJ (AM TRACKING)		Q102	8-729-037-89	TRANSISTOR 2SC4627J-C(TX).SO	
CT102	1-141-615-21	CAP, ADJ (FM TRACKING)		Q103	8-729-037-71	TRANSISTOR UN9210J-(TX).SO	
		< DIODE >		Q104	8-729-037-71	TRANSISTOR UN9210J-(TX).SO	
D101	8-719-421-40	DIODE MA77		Q201	8-729-037-53	TRANSISTOR 2SB1462J-QR(TX).SO	
D102	8-719-072-59	DIODE SVC347S-TL		Q202	8-729-037-53	TRANSISTOR 2SB1462J-QR(TX).SO	
D103	8-719-075-24	DIODE HVC363BTRU (JE)		Q203	8-729-800-37	TRANSISTOR 2SD1048-X7	
D103	8-719-076-23	DIODE HVC202B TRU (US,AEP,E)		Q204	8-729-800-37	TRANSISTOR 2SD1048-X7	
D104	8-719-075-24	DIODE HVC363BTRU (JE)		Q205	8-729-800-37	TRANSISTOR 2SD1048-X7	
D104	8-719-076-23	DIODE HVC202B TRU (US,AEP,E)		Q206	8-729-037-53	TRANSISTOR 2SB1462J-QR(TX).SO	
D105	8-719-820-41	DIODE 1SS302		Q302	8-729-037-92	TRANSISTOR 2SD2216J-R(TX).SO	
D106	8-719-071-34	DIODE RB521S-30-TE61		Q303	8-729-800-71	TRANSISTOR 2SB815B7-TB	
D107	8-719-071-34	DIODE RB521S-30-TE61		Q401	8-729-037-92	TRANSISTOR 2SD2216J-R(TX).SO	
D109	8-719-820-41	DIODE 1SS302		Q402	8-729-037-92	TRANSISTOR 2SD2216J-R(TX).SO	
D301	8-719-084-27	LED SLI-343YCT32WST (LCD BACK LIGHT)		Q403	8-729-037-71	TRANSISTOR UN9210J-(TX).SO	
D302	8-719-084-27	LED SLI-343YCT32WST (LCD BACK LIGHT)		Q404	8-729-800-71	TRANSISTOR 2SB815B7-TB	
D303	8-719-071-34	DIODE RB521S-30-TE61				< RESISTOR >	
D304	8-719-071-34	DIODE RB521S-30-TE61		R101	1-218-985-11	RES-CHIP 470K 5% 1/16W	
D401	8-719-071-34	DIODE RB521S-30-TE61		R102	1-218-977-11	RES-CHIP 100K 5% 1/16W	
D402	8-719-046-91	DIODE MA2S111		R103	1-218-965-11	RES-CHIP 10K 5% 1/16W	
D403	8-719-420-87	DIODE MA8130		R104	1-218-953-11	RES-CHIP 1K 5% 1/16W	
		< IC >		R106	1-218-965-11	RES-CHIP 10K 5% 1/16W	
IC101	8-752-100-32	IC CXA1238N-T4		R107	1-218-977-11	RES-CHIP 100K 5% 1/16W	
IC201	8-752-065-32	IC CXA1522N-T4		R108	1-216-827-11	METAL CHIP 3.3K 5% 1/16W	
IC301	8-759-836-09	IC TC9328AF-SR7491		R109	1-218-977-11	RES-CHIP 100K 5% 1/16W	
IC302	8-759-578-28	IC S-80819ANNP-EDG-T2		R110	1-218-969-11	RES-CHIP 22K 5% 1/16W	
IC303	8-759-690-72	IC XC61CN0902NR		R111	1-218-945-11	RES-CHIP 220 5% 1/16W	
IC304	8-759-690-97	IC XC61CN1102NR		R112	1-218-941-11	RES-CHIP 100 5% 1/16W	
IC305	8-759-568-85	IC S-80821ANNP-EDJ-T2		R113	1-218-965-11	RES-CHIP 10K 5% 1/16W	
IC401	8-759-516-90	IC S-81218SG-QR-T1		R114	1-218-989-11	RES-CHIP 1M 5% 1/16W	
		< JACK >		R115	1-218-957-11	RES-CHIP 2.2K 5% 1/16W	
J201	1-507-893-21	JACK, MICROPHONE (☪)		R116	1-218-945-11	RES-CHIP 220 5% 1/16W	
		< COIL >		R117	1-216-827-11	METAL CHIP 3.3K 5% 1/16W	
L101	1-412-967-31	INDUCTOR 0.1uH		R118	1-216-827-11	METAL CHIP 3.3K 5% 1/16W	
L102	1-501-974-41	ANTENNA, FERRITE-BAR (MW) (AM TRACKING)		R119	1-208-635-11	RES-CHIP 10 5% 1/16W	
L103	1-416-903-21	COIL (WITH CORE) (AM TRACKING) (JE)		R120	1-218-971-11	RES-CHIP 33K 5% 1/16W	
L103	1-424-804-21	COIL, RF (FM TRACKING) (US,AEP,E)		R121	1-218-957-11	RES-CHIP 2.2K 5% 1/16W	
				R122	1-218-953-11	RES-CHIP 1K 5% 1/16W	
				R123	1-218-985-11	RES-CHIP 470K 5% 1/16W	
				R124	1-218-985-11	RES-CHIP 470K 5% 1/16W	
				R125	1-218-985-11	RES-CHIP 470K 5% 1/16W	
				R126	1-208-635-11	RES-CHIP 10 5% 1/16W	

ICF-C1200

MAIN

Ref. No.	Part No.	Description	Remark	Ref. No.	Part No.	Description	Remark
R127	1-216-864-11	SHORT	0	R342	1-218-989-11	RES-CHIP	1M 5% 1/16W
R128	1-218-990-11	SHORT	0	R343	1-218-965-11	RES-CHIP	10K 5% 1/16W
R129	1-803-120-21	THERMISTOR, NTC		R344	1-218-965-11	RES-CHIP	10K 5% 1/16W
R130	1-216-813-11	RES-CHIP	220 5%	R345	1-218-953-11	RES-CHIP	1K 5% 1/16W
R131	1-218-953-11	RES-CHIP	1K 5%	R346	1-218-989-11	RES-CHIP	1M 5% 1/16W
R201	1-218-973-11	RES-CHIP	47K 5%	R349	1-218-953-11	RES-CHIP	1K 5% 1/16W
R202	1-218-961-11	RES-CHIP	4.7K 5%	R350	1-218-989-11	RES-CHIP	1M 5% 1/16W
R203	1-218-956-11	RES-CHIP	1.8K 5%	R351	1-218-965-11	RES-CHIP	10K 5% 1/16W
R204	1-218-961-11	RES-CHIP	4.7K 5%	R352	1-218-981-11	RES-CHIP	220K 5% 1/16W
R205	1-218-973-11	RES-CHIP	47K 5%	R353	1-218-981-11	RES-CHIP	220K 5% 1/16W
R206	1-218-945-11	RES-CHIP	220 5%	R354	1-218-981-11	RES-CHIP	220K 5% 1/16W
R207	1-218-945-11	RES-CHIP	220 5%	R355	1-218-981-11	RES-CHIP	220K 5% 1/16W
R210	1-218-961-11	RES-CHIP	4.7K 5%	R356	1-218-985-11	RES-CHIP	470K 5% 1/16W
R211	1-218-961-11	RES-CHIP	4.7K 5%	R357	1-218-985-11	RES-CHIP	470K 5% 1/16W
R212	1-208-635-11	RES-CHIP	10 5%	R358	1-218-985-11	RES-CHIP	470K 5% 1/16W
R213	1-218-953-11	RES-CHIP	1K 5%	R359	1-218-985-11	RES-CHIP	470K 5% 1/16W
R214	1-218-977-11	RES-CHIP	100K 5%	R360	1-218-985-11	RES-CHIP	470K 5% 1/16W
R215	1-218-989-11	RES-CHIP	1M 5%	R361	1-218-985-11	RES-CHIP	470K 5% 1/16W
R301	1-218-985-11	RES-CHIP	470K 5%	R362	1-218-981-11	RES-CHIP	220K 5% 1/16W
R302	1-218-953-11	RES-CHIP	1K 5%	R363	1-218-985-11	RES-CHIP	470K 5% 1/16W
R303	1-218-953-11	RES-CHIP	1K 5%	R364	1-218-981-11	RES-CHIP	220K 5% 1/16W
R304	1-218-953-11	RES-CHIP	1K 5%	R365	1-218-985-11	RES-CHIP	470K 5% 1/16W
R305	1-218-953-11	RES-CHIP	1K 5%	R366	1-218-985-11	RES-CHIP	470K 5% 1/16W
R306	1-218-953-11	RES-CHIP	1K 5%	R367	1-218-985-11	RES-CHIP	470K 5% 1/16W
R307	1-218-953-11	RES-CHIP	1K 5%	R368	1-218-985-11	RES-CHIP	470K 5% 1/16W
R308	1-218-953-11	RES-CHIP	1K 5%	R369	1-218-985-11	RES-CHIP	470K 5% 1/16W
R309	1-218-953-11	RES-CHIP	1K 5%	R370	1-218-985-11	RES-CHIP	470K 5% 1/16W
R310	1-218-953-11	RES-CHIP	1K 5%	R371	1-218-985-11	RES-CHIP	470K 5% 1/16W
R311	1-218-953-11	RES-CHIP	1K 5%	R372	1-218-985-11	RES-CHIP	470K 5% 1/16W
R312	1-218-953-11	RES-CHIP	1K 5%	R373	1-218-985-11	RES-CHIP	470K 5% 1/16W
R313	1-218-953-11	RES-CHIP	1K 5%	R374	1-218-985-11	RES-CHIP	470K 5% 1/16W
R314	1-218-965-11	RES-CHIP	10K 5%	R375	1-218-981-11	RES-CHIP	220K 5% 1/16W
R315	1-218-985-11	RES-CHIP	220K 5%	R376	1-218-981-11	RES-CHIP	220K 5% 1/16W
R316	1-218-965-11	RES-CHIP	10K 5%	R377	1-218-985-11	RES-CHIP	470K 5% 1/16W
R317	1-218-965-11	RES-CHIP	10K 5%	R379	1-218-990-11	SHORT	0
R318	1-218-965-11	RES-CHIP	10K 5%	R380	1-218-985-11	RES-CHIP	470K 5% 1/16W
R319	1-218-989-11	RES-CHIP	1M 5%	R381	1-208-635-11	RES-CHIP	10 5% 1/16W
R320	1-218-953-11	RES-CHIP	1K 5%	R382	1-218-990-11	SHORT	0
R321	1-218-953-11	RES-CHIP	1K 5%	R383	1-218-953-11	RES-CHIP	1K 5% 1/16W
R322	1-218-977-11	RES-CHIP	100K 5%	R384	1-218-953-11	RES-CHIP	1K 5% 1/16W
			(JE)	R385	1-218-953-11	RES-CHIP	1K 5% 1/16W
R323	1-218-977-11	RES-CHIP	100K 5%	R386	1-218-953-11	RES-CHIP	1K 5% 1/16W
			(US,AEP,E)	R387	1-218-990-11	SHORT	0
R324	1-218-985-11	RES-CHIP	470K 5%	R388	1-218-941-11	RES-CHIP	100 5% 1/16W
R325	1-218-985-11	RES-CHIP	470K 5%	R389	1-218-937-11	RES-CHIP	47 5% 1/16W
R326	1-218-985-11	RES-CHIP	470K 5%	R390	1-218-969-11	RES-CHIP	22K 5% 1/16W
R327	1-208-635-11	RES-CHIP	10 5%	R391	1-218-990-11	SHORT	0
R328	1-218-953-11	RES-CHIP	1K 5%	R392	1-218-990-11	SHORT	0
R329	1-218-953-11	RES-CHIP	1K 5%	R401	1-218-953-11	RES-CHIP	1K 5% 1/16W
R331	1-218-961-11	RES-CHIP	4.7K 5%	R402	1-218-981-11	RES-CHIP	220K 5% 1/16W
R332	1-218-989-11	RES-CHIP	1M 5%	R403	1-218-977-11	RES-CHIP	100K 5% 1/16W
R333	1-218-965-11	RES-CHIP	10K 5%	R404	1-218-973-11	RES-CHIP	47K 5% 1/16W
R337	1-218-977-11	RES-CHIP	100K 5%	R405	1-218-937-11	RES-CHIP	47 5% 1/16W
			(US,JE)	R406	1-218-957-11	RES-CHIP	2.2K 5% 1/16W
R338	1-218-977-11	RES-CHIP	100K 5%	R407	1-218-945-11	RES-CHIP	220 5% 1/16W
			(AEP,E)			< VARIABLE RESISTOR >	
R339	1-218-953-11	RES-CHIP	1K 5%				
R340	1-218-953-11	RES-CHIP	1K 5%	RV101	1-241-479-11	RES, ADJ, CERMET 22K (VCO)	
R341	1-218-953-11	RES-CHIP	1K 5%	RV201	1-237-870-11	RES, VAR, CARBON 20K (VOL)	

Ref. No.	Part No.	Description	Remark
		< SWITCH >	
S301	1-771-790-21	SWITCH, SLIDE (HOLD)	
S302	1-786-015-21	SWITCH, TACTILE (RADIO ON/SLEEP)	
S303	1-786-015-21	SWITCH, TACTILE (OFF)	
S304	1-771-627-21	SWITCH, TACTILE (MENU)	
S305	1-786-015-21	SWITCH, TACTILE (WORLD/LOCAL)	
S306	1-572-473-11	SWITCH, TACTILE (SNOOZE)	
S307	1-786-015-21	SWITCH, TACTILE (LIGHT)	
S308	1-786-015-21	SWITCH, TACTILE (▶ JOG SWITCH)	
S309	1-786-015-21	SWITCH, TACTILE (◀ JOG SWITCH)	
S310	1-771-627-21	SWITCH, TACTILE (BAND/ENT)	
S311	1-692-605-31	SWITCH, SLIDE (ALARM MODE)	
		< TRANSFORMER >	
T101	1-416-019-11	TRANSFORMER, IF (AM) (AM IF)	
T401	1-449-021-21	COIL, DC/DC CONVERTER	
		< VIBRATOR >	
X301	1-795-329-21	VIBRATOR, CRYSTAL (75kHz)	

		MISCELLANEOUS	

11	1-694-596-11	CONDUCTIVE BOARD, CONNECTION	
L102	1-501-974-41	ANTENNA, FERRITE-BAR (MW)	(AM TRACKING)
SP101	1-529-187-11	SPEAKER (2.8cm)	
ANT101	1-754-183-11	ANTENNA, TELESCOPIC	
LCD101	1-804-341-11	DISPLAY PANEL, LIQUID CRYSTAL	

		ACCESSORIES & PACKING MATERIALS	

3-229-569-01		MANUAL, INSTRUCTION (JAPANESE,KOREAN,SIMPLIFIED CHINESE)(E,JE)	
3-229-569-11		MANUAL, INSTRUCTION (DUTCH,GERMAN,ITALIAN)(AEP)	
3-229-569-21		MANUAL, INSTRUCTION (ENGLISH,FRENCH,SPANISH)	
3-229-569-31		MANUAL, INSTRUCTION (PORTUGUESE,SWEDISH,,DANISH,FINNISH) (AEP)	
8-953-301-93		RECEIVER,EAR MDR-E805LP	
X-3380-571-1		COVER ASSY	

