

ICF-C253

SERVICE MANUAL

Australian Model

Ver 1.0 2000.04



SPECIFICATIONS

Time display

12-hour system

Frequency range

FM: 87.5–108 MHz

AM: 530–1,710 kHz

Channel steps

FM: 0.1 MHz (fixed)

AM: 10 kHz (fixed)

Speaker

Approx. 6.6 cm (2⁵/₈ in) dia.

Power output

200 mW (at 10% harmonic distortion)

Power requirements

120 V AC, 60 Hz

Dimensions

Approx. 180.5 × 55 × 140 mm (w/h/d)
(7¹/₈ × 2¹/₄ × 5⁵/₈ in) incl. projecting
parts and controls

Mass

Approx. 640 g (1 lb 7 oz)

Design and specifications are subject to change
without notice.

FM/AM PLL SYNTHESIZED CLOCK RADIO

SONY®

SECTION 1 GENERAL

This section is extracted
from instruction manual.

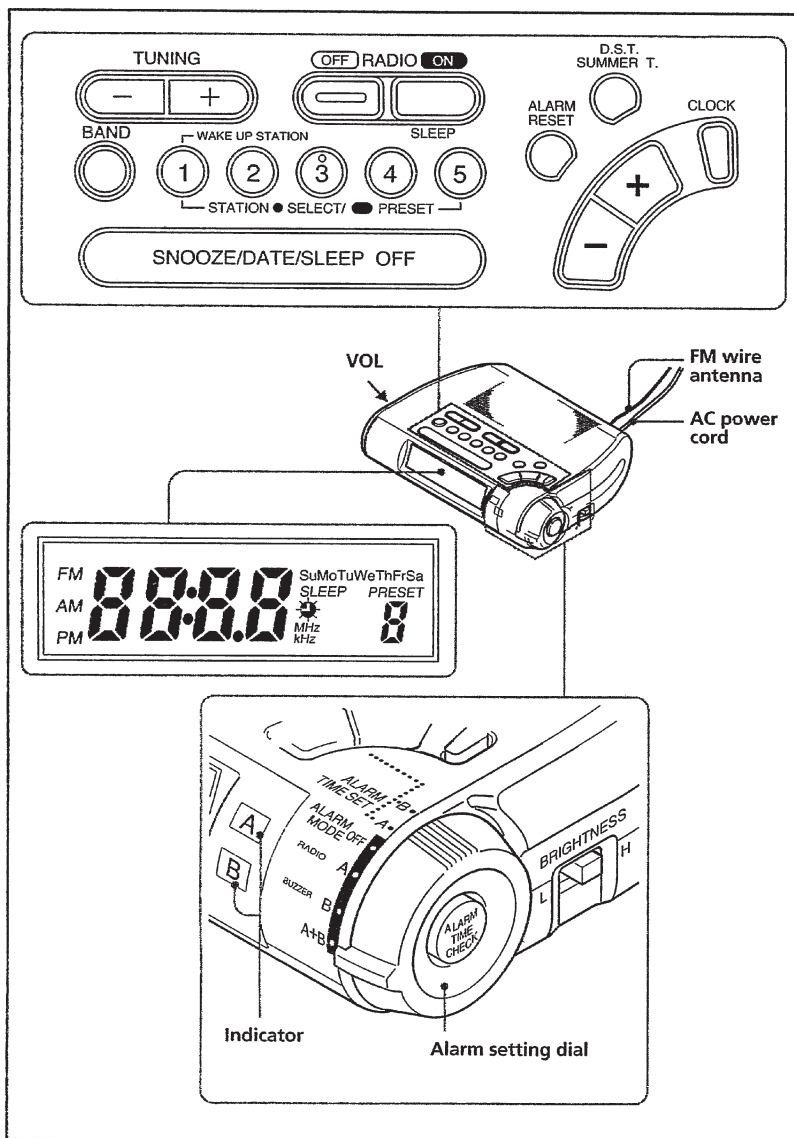

Setting the Clock

- 1** Set the alarm setting dial to **ALARM MODE OFF**.
- 2** Plug in the clock radio.
The display will flash "AM 12:00".
- 3** Press **CLOCK** for a few seconds.
You will hear a beep and the year will start to flash in the display.
- 4** Press **CLOCK +** or **-** until the correct year appears in the display.
- 5** Press **CLOCK** once.
- 6** Repeat steps **4** and **5** to set the month, date, hour, and minute.
After setting the minute, press **CLOCK** to start the counting of the seconds, and you will hear two short beeps.

- To display the year and date, press **SNOOZE/DATE/SLEEP OFF** once for the date, and within 2 seconds press it again for the year. The display shows the date or year for a few seconds and then changes back to the current time.
- To set the current time rapidly, hold down **CLOCK +** or **-**.
- In step **6**, when you press **CLOCK** after the minute setting to activate the clock, the seconds start counting from zero.
- When the alarm setting dial is set to **ALARM TIME SET A** or **B**, the clock cannot be set.

To change the display to the daylight saving time (summer time) indication

Press **D.S.T./SUMMER T**.
"☀" is displayed and the time indication changes to summer time.
To deactivate the summer time function, press **D.S.T./SUMMER T** again.

To set the brightness of the backlight

Set **BRIGHTNESS** for the display to **H** (high) or **L** (low) according to your preference.

SAFETY CHECK-OUT

After correcting the original service problem, perform the following safety checks before releasing the set to the customer.

1. Check the area of your repair for unsoldered or poorly-soldered connections. Check the entire board surface for solder splashes and bridges.
2. Check the interboard wiring to ensure that no wires are "pinched" or contact high-wattage resistors.
3. Look for unauthorized replacement parts, particularly transistors, that were installed during a previous repair. Point them out to the customer and recommend their replacement.
4. Look for parts which, through functioning, show obvious signs of deterioration. Point them out to the customer and recommend their replacement.
5. Check the B+ voltage to see it is at the values specified.
6. Flexible Circuit Board Repairing
 - Keep the temperature of the soldering iron around 270°C during repairing.
 - Do not touch the soldering iron on the same conductor of the circuit board (within 3 times).
 - Be careful not to apply force on the conductor when soldering or unsoldering.

SECTION 2 DISASSEMBLY

- The equipment can be removed using the following procedure.

Set → Cabinet (upper) → Key board → Main board → Power board

Note : Follow the disassembly procedure in the numerical order given.

2-1. CABINET (UPPER)

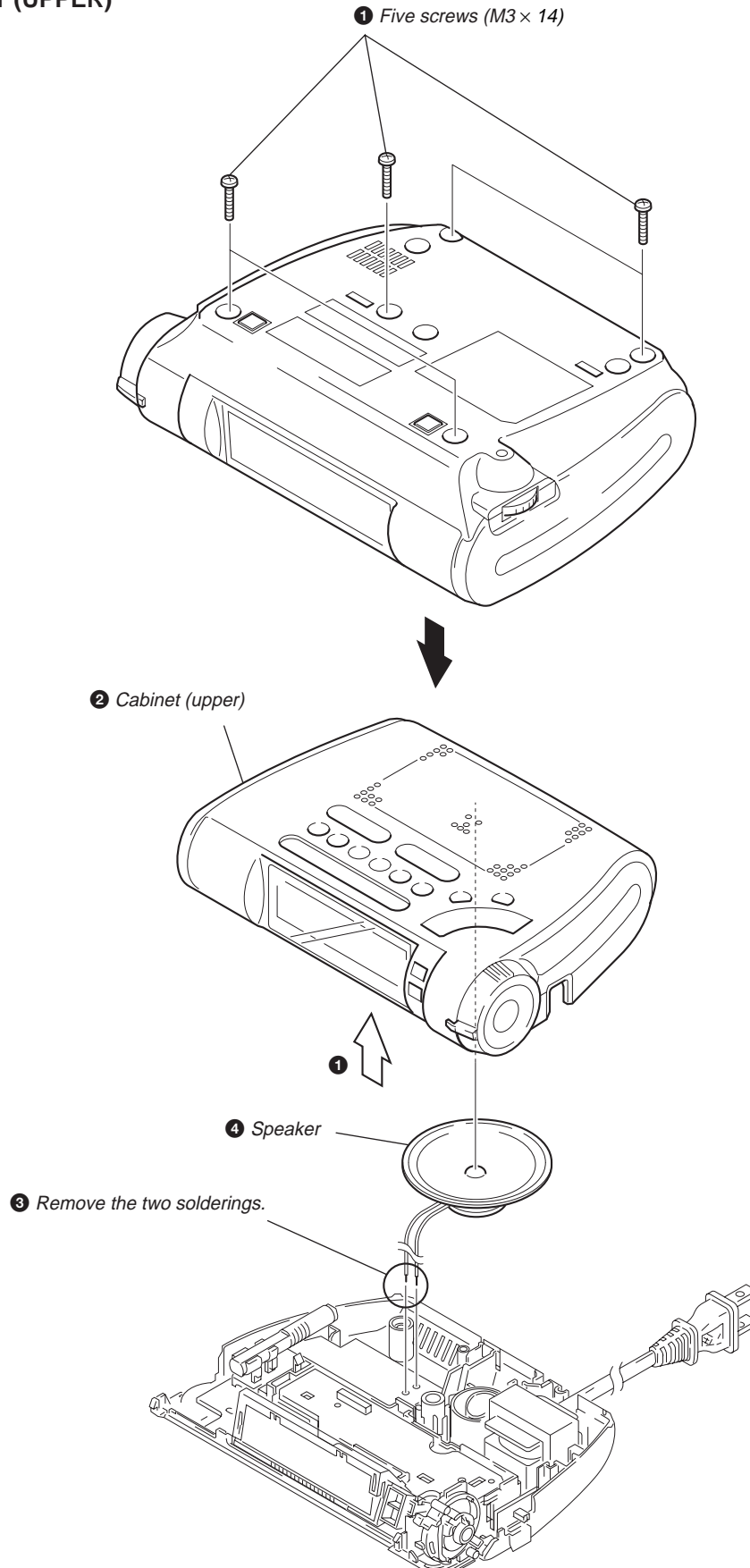

2-2. KEY BOARD

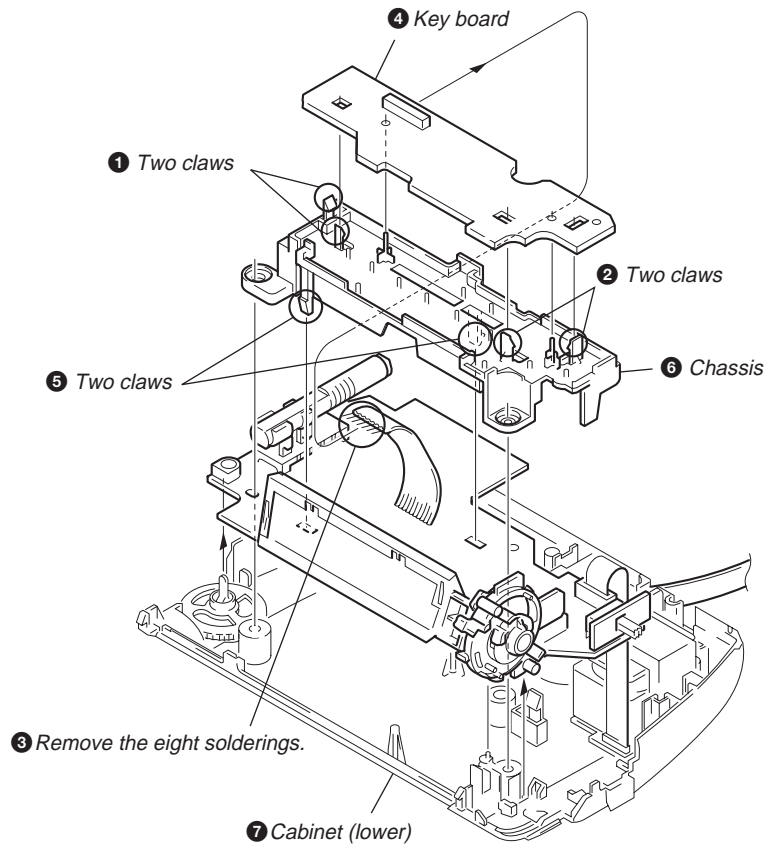

2-3. MAIN BOARD

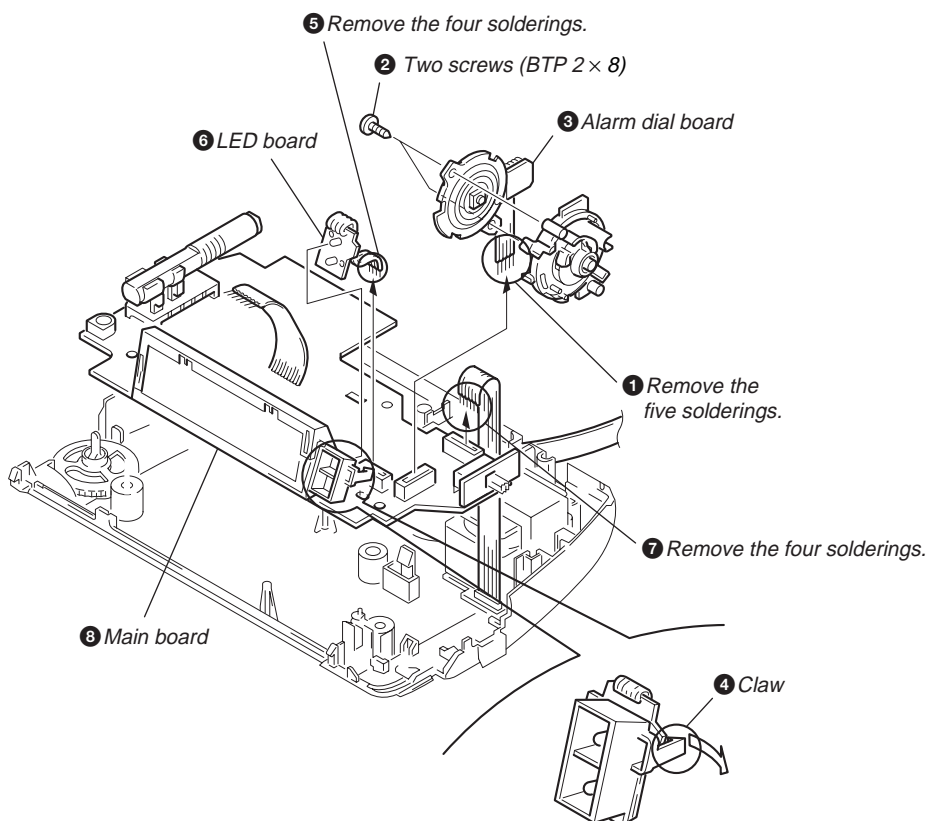

SECTION 3 ELECTRICAL ADJUSTMENTS

2-4. POWER BOARD

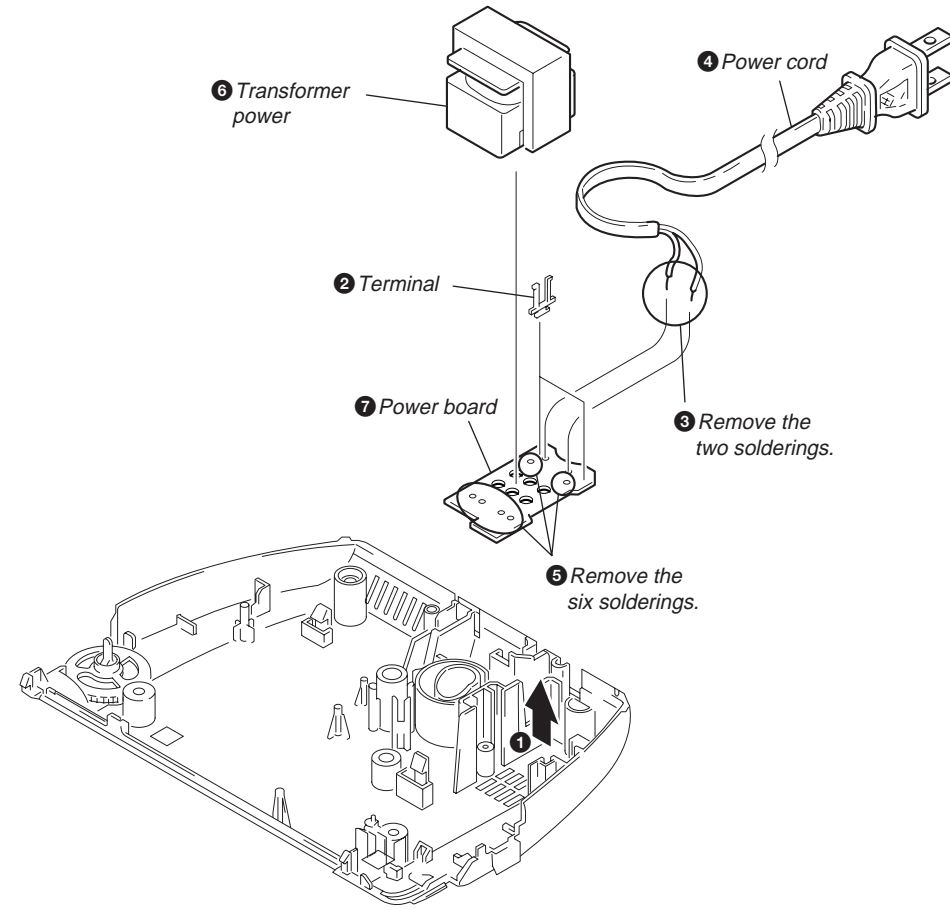

2-5. POWER CORD SETTING

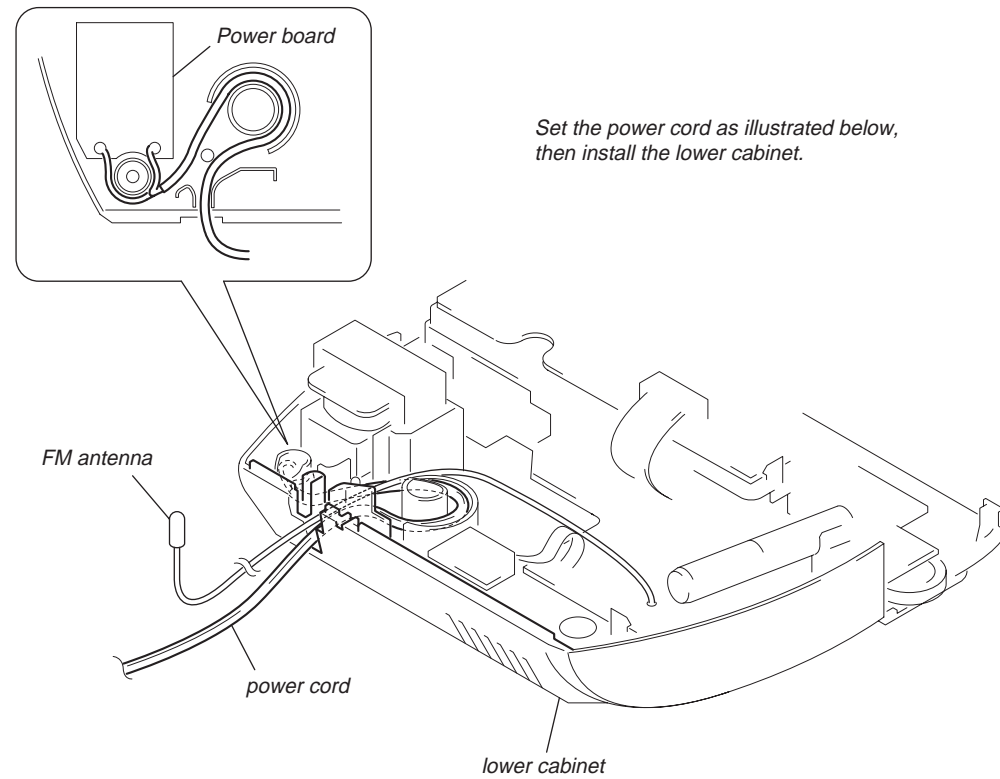

• Adjusting Location: MAIN board (Component Side)

[FM]
Setting:
BAND switch: FM

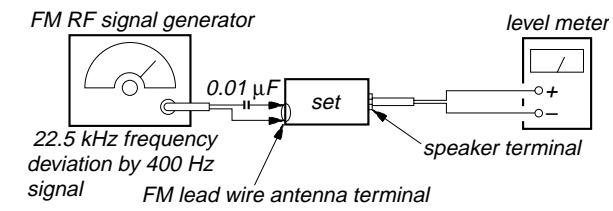

[AM]
Setting:
BAND switch: AM

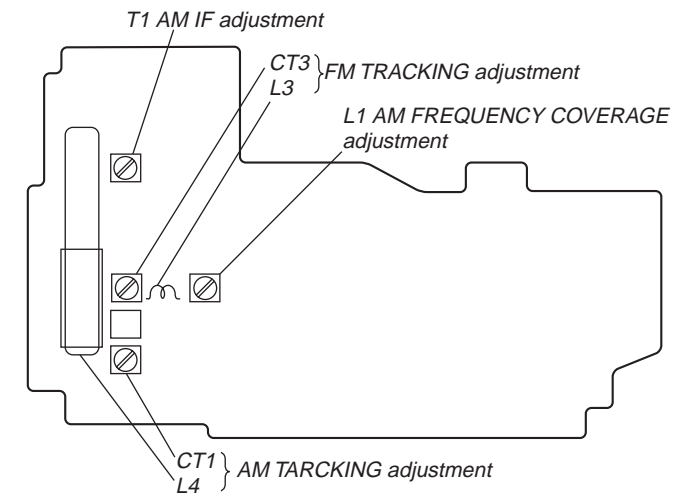
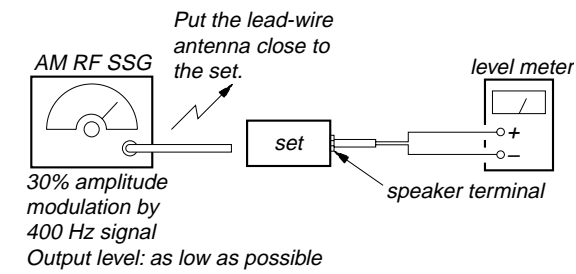

Repeat the procedures in each adjustment several times, and the frequency coverage and tracking adjustments should be finally done by the trimmer capacitors.

FM TRACKING ADJUSTMENT	
Adjust for a maximum reading on level meter.	
L3	CT3
87.5 MHz	108 Hz

AM FREQUENCY COVERAGE ADJUSTMENT	
Adjust for a maximum reading on level meter.	
L1	
531 kHz	

AM TRACKING ADJUSTMENT	
Adjust for a maximum reading on level meter.	
L4	CT1
621 kHz	1,404 kHz

AM IF ADJUSTMENT	
Adjust for a maximum reading on level meter.	
T1	
450 kHz	

SECTION 4
DIAGRAMS

4-1. PRINTED WIRING BOARDS

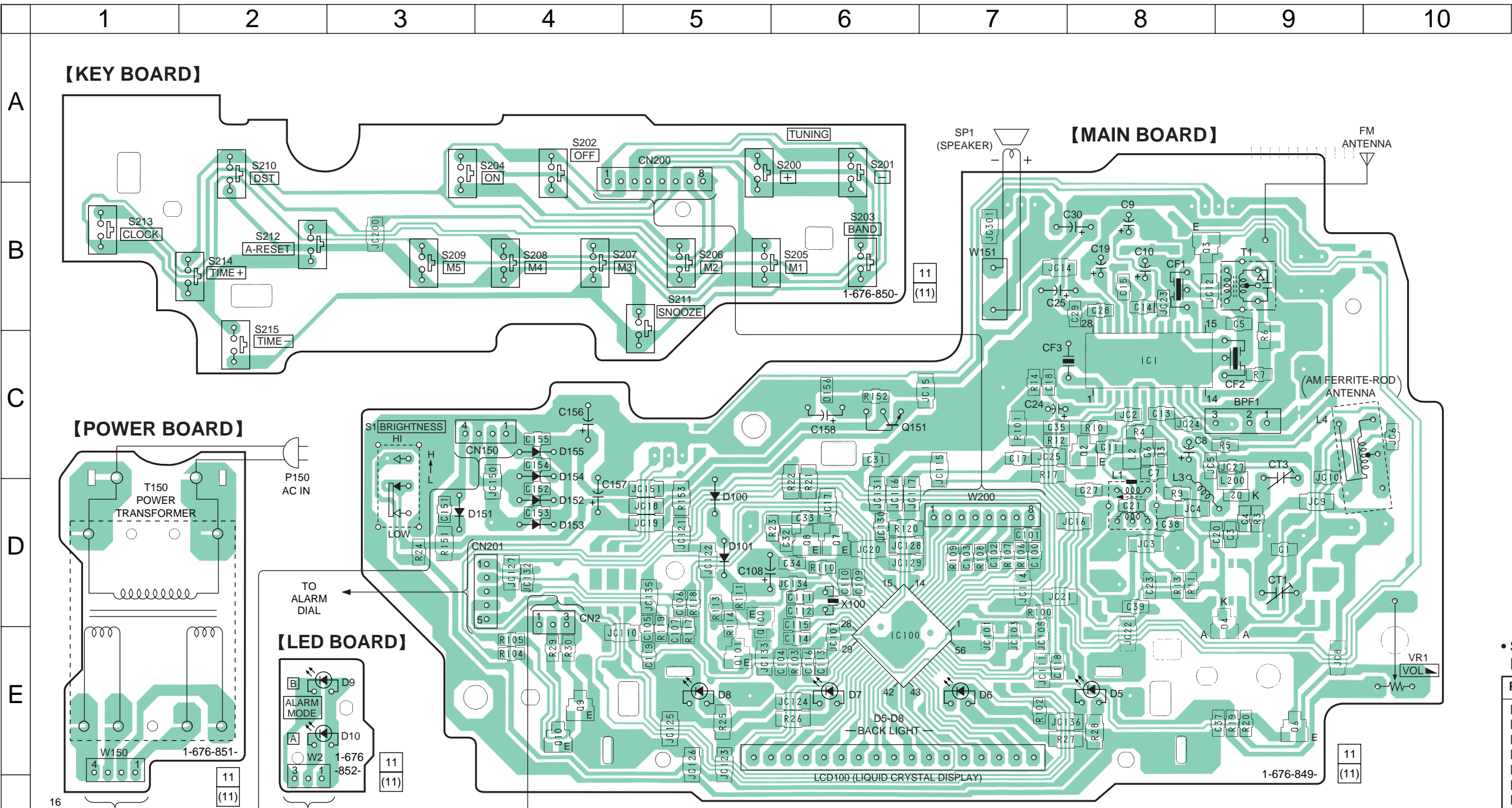

• Semiconductor Location

Ref. No.	Location
D5	E-8
D6	E-7
D7	E-6
D8	E-5
D9	E-3
D10	E-3
D100	D-5
D101	D-5
D151	D-4
D152	D-4
D153	D-4
D154	C-4
D155	C-4
D156	C-4
IC1	C-8
IC100	E-6
Q2	C-7
Q3	B-8
Q6	E-9
Q7	D-6
Q8	D-6
Q9	E-4
Q10	E-4
Q100	E-5
Q101	E-5
Q151	C-6

Note on Printed Wiring Boards:
 • — : parts extracted from the component side.
 • : Pattern from the side which enables seeing.

4-2. SCHEMATIC DIAGRAM

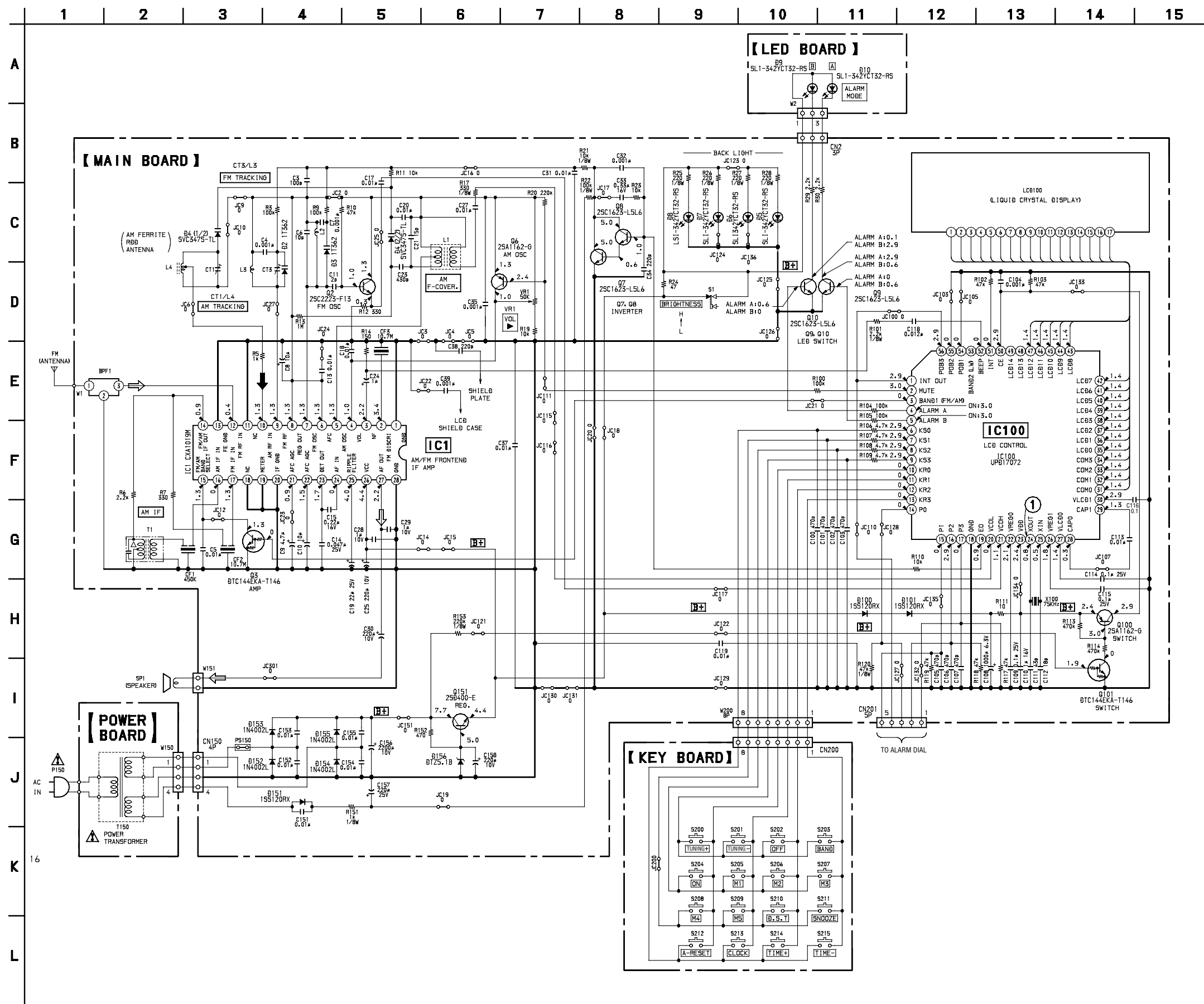

Note on Schematic Diagram:

- All capacitors are in μF unless otherwise noted. pF : μF 50 WV or less are not indicated except for electrolytics and tantalums.
- All resistors are in Ω and $1/4\text{ W}$ or less unless otherwise specified.
- Δ : internal component.
- \square : panel designation.

The components identified by mark Δ or dotted line with mark Δ are critical for safety. Replace only with part number specified.

- \square B+ : B+ Line.
- \square : adjustment for repair.
- Voltages are dc with respect to ground under no-signal (detuned) conditions.
 - no mark : FM
 - () : AM
 - * : Impossible to measure
- Voltages are taken with a VOM (Input impedance 10 M Ω). Voltage variations may be noted due to normal production tolerances.
- Signal path.
 - \Rightarrow : FM
 - \blackrightarrow : AM

Waveform

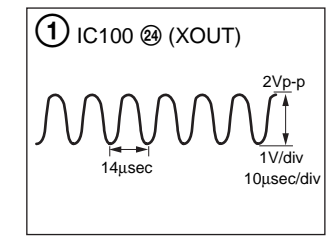

4-3. IC PIN FUNCTION DESCRIPTION

• IC100 LCD CONTROL (μPD17072GB-019-1A7)

Pin No.	Pin Name	I/O	Description
1	INT OUT	O	Initialization output.
2	MUTE	O	Mute output.
3	BAND1	O	Band output.
4	ALARM A	O	ALARM A indicator.
5	ALARM B	O	ALARM B indicator.
6 to 9	KS0 to KS3	O	Key strove signal.
10 to 13	XR0 to XR3	I	Key return signal.
14	P0	I	ALARM-TIME input.
15 to 17	P1 to P3	I	DIAL signal.
18	GND	-	Ground.
19	E0	O	PLL error output.
20	VCOL	I	LW/MW VCO input.
21	VCOH	I	FM VCO input.
22	Vreg0	-	Regulator.
23	VDD	-	VDD
24	Xout	O	System clock output.
25	Xin	I	System clock input.
26	Vreg1	-	Regulator.
27	VLCD0	-	LCD bubbler.
28, 29	CAP0, CAP1	-	
30	VLCD1	-	
31 to 34	COM0 to COM3	O	LCD drive. Common signal.
35 to 47	LCD0 to LCD12	O	LCD drive. Segment signal.
48, 49	LCD13, LCD14	O	Not used.
50	CE	I	Power failure detection.
51	INT	I	Not used.
52	BEEP	O	Buzzer output.
53	BAND2	O	Band output.
54 to 56	INIT IN	I	Initialization input.

SECTION 5 EXPLODED VIEWS

NOTE:

- -XX, -X mean standardized parts, so they may have some differences from the original one.
- Items marked “*” are not stocked since they are seldom required for routine service. Some delay should be anticipated when ordering these items.

- The mechanical parts with no reference number in the exploded views are not supplied.
- Accessories and packing materials are given in the last of this parts list.

The components identified by mark Δ or dotted line with mark Δ are critical for safety. Replace only with part number specified.

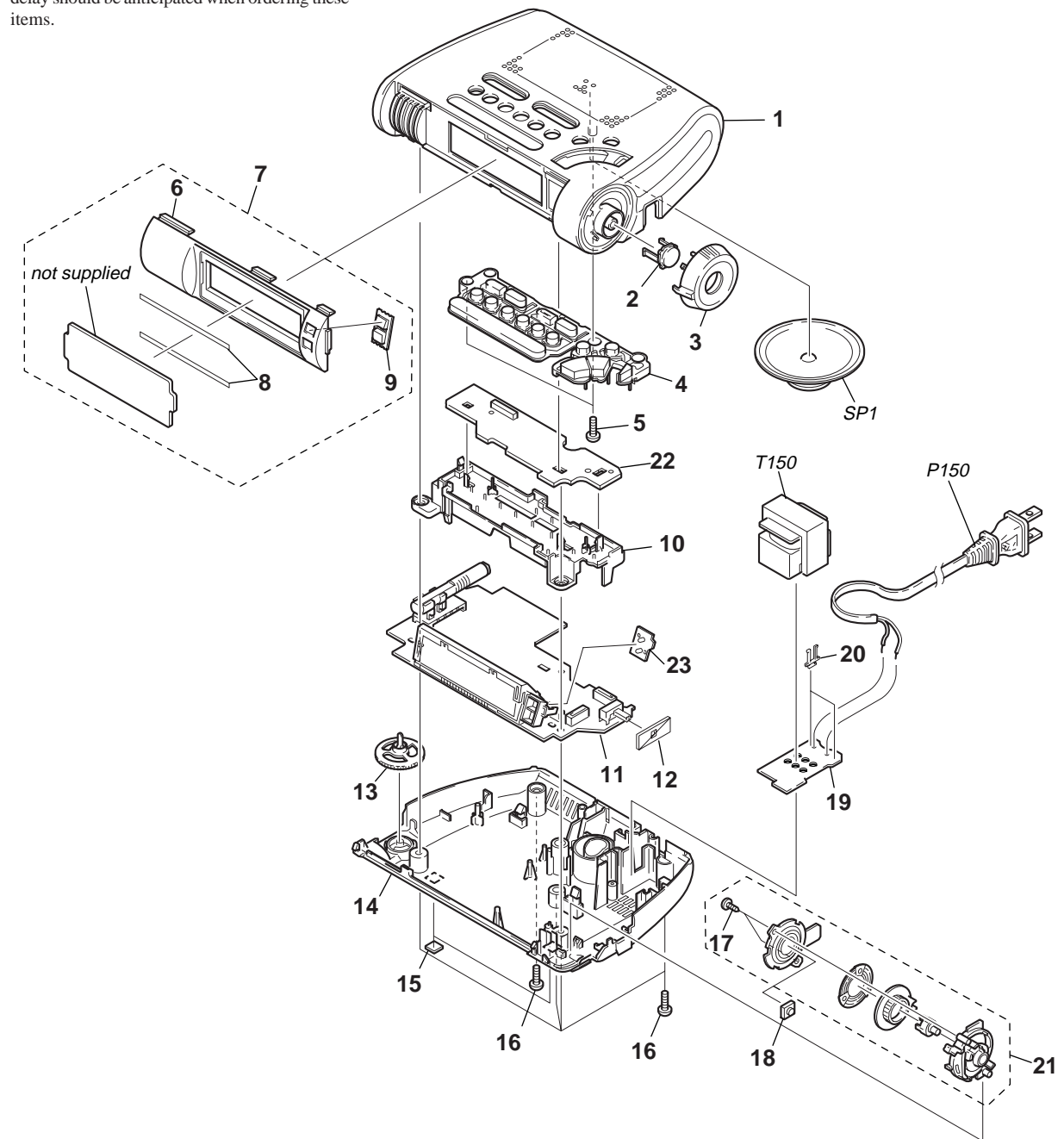

Ref. No.	Part No.	Description	Remarks	Ref. No.	Part No.	Description	Remarks
1	3-045-666-11	CABINET (UPPER)		14	3-045-667-11	CABINET (LOWER)	
2	3-045-669-01	KNOB(ALARM)		15	3-368-852-01	FOOT	
3	3-045-670-11	BUTTON (ALARM)		16	7-685-649-79	SCREW +P 3X14 TYPE2 NON-SLIT	
4	3-045-668-11	BUTTON (MAIN)		17	3-371-765-21	SCREW (2X8), +BTP	
5	7-685-647-79	SCREW+P 3X10 TYPE2 NON-SLIT		18	1-553-856-00	SWITCH, KEYBOARD	
6	3-045-675-01	PANEL, FRONT		* 19	1-676-851-11	POWER BOARD	
7	X-3378-799-1	PANELASSY, FRONT		* 20	1-535-771-11	TERMINAL	
8	3-049-387-01	SHEET(WINDOW), ADHESIVE		21	A-3638-829-A	DIAL (ALARM) ASSY	
9	3-045-677-01	WINDOW (LED)		22	1-676-850-11	KEY BOARD	
10	3-045-672-01	CHASSIS		23	1-676-852-11	LED BOARD	
* 11	A-3683-190-A	MAIN BOARD, COMPLETE		SP1	1-504-748-21	SPEAKER (6.6cm)	
12	3-933-547-01	SHEET (BAND)		Δ P150	1-790-431-11	CORD, POWER	
13	3-919-268-01	KNOB(VOL)		Δ T150	1-435-504-11	TRANSFORMER, POWER	

SECTION 6 ELECTRICAL PARTS LIST

KEY

LED

MAIN

NOTE:

- Due to standardization, replacements in the parts list may be different from the parts specified in the diagrams or the components used on the set.
- -XX, -X mean standardized parts, so they may have some difference from the original one.
- Items marked "*" are not stocked since they are seldom required for routine service. Some delay should be anticipated when ordering these items.

- CAPACITORS:
uF: μ F
- RESISTORS
All resistors are in ohms.
METAL: metal-film resistor
METAL OXIDE: Metal Oxide-film resistor
F: nonflammable
- COILS
uH: μ H

- SEMICONDUCTORS
In each case, u: μ , for example:
uA...: μ A..., uPA..., μ PA...,
uPB..., μ PB..., uPC..., μ PC...,
uPD..., μ PD...

When indicating parts by reference number, please include the board name.

The components identified by mark Δ or dotted line with mark Δ are critical for safety. Replace only with part number specified.

Ref. No.	Part No.	Description	Remarks	Ref. No.	Part No.	Description	Remarks
	1-676-850-11	KEY BOARD *****		C8	1-126-964-11	ELECT 10uF 20%	50V
		< CONNECTOR >		C9	1-126-963-11	ELECT 4.7uF 20%	50V
* CN200	1-580-187-11	SOCKET, CONNECTOR 8P < JUMPER >		C10	1-126-964-11	ELECT 10uF 20%	50V
JC200	1-216-296-91	SHORT 0 < SWITCH >		C11	1-163-085-00	CERAMIC CHIP 2PF	50V
S200	1-692-014-11	SWITCH, KEY BOARD (+)		C13	1-163-021-91	CERAMIC CHIP 0.01uF 10%	50V
S201	1-692-014-11	SWITCH, KEY BOARD (-)		C14	1-163-809-11	CERAMIC CHIP 0.047uF 10%	25V
S202	1-692-014-11	SWITCH, KEY BOARD (OFF)		C15	1-164-489-11	CERAMIC CHIP 0.22uF 10%	16V
S203	1-692-014-11	SWITCH, KEY BOARD (BAND)		C17	1-163-021-91	CERAMIC CHIP 0.01uF 10%	50V
S204	1-692-014-11	SWITCH, KEY BOARD (ON)		C18	1-163-021-91	CERAMIC CHIP 0.01uF 10%	50V
S205	1-692-014-11	SWITCH, KEY BOARD (M1)		C19	1-128-551-11	ELECT 22uF 20%	25V
S206	1-692-014-11	SWITCH, KEY BOARD (M2)		C20	1-163-021-91	CERAMIC CHIP 0.01uF 10%	50V
S207	1-692-014-11	SWITCH, KEY BOARD (M3)		C21	1-163-231-11	CERAMIC CHIP 15PF 5%	50V
S208	1-692-014-11	SWITCH, KEY BOARD (M4)		C23	1-163-132-00	CERAMIC CHIP 430PF 5%	50V
S209	1-692-014-11	SWITCH, KEY BOARD (M5)		C24	1-126-960-11	ELECT 1uF 20%	50V
S210	1-692-014-11	SWITCH, KEY BOARD (D.S.T)		C25	1-126-934-11	ELECT 220uF 20%	10V
S211	1-692-014-11	SWITCH, KEY BOARD (SNOOZE)		C27	1-163-021-91	CERAMIC CHIP 0.01uF 10%	50V
S212	1-692-014-11	SWITCH, KEY BOARD (A-RESET)		C28	1-109-982-11	CERAMIC CHIP 1uF 10%	10V
S213	1-692-014-11	SWITCH, KEY BOARD (CLOCK)		C29	1-109-982-11	CERAMIC CHIP 1uF 10%	10V
S214	1-692-014-11	SWITCH, KEY BOARD (TIME +)		C30	1-126-934-11	ELECT 220uF 20%	10V
S215	1-692-014-11	SWITCH, KEY BOARD (TIME -)		C31	1-163-021-91	CERAMIC CHIP 0.01uF 10%	50V
*****				C32	1-163-009-11	CERAMIC CHIP 0.001uF 10%	50V
	1-676-852-11	LED BOARD *****		C33	1-110-501-11	CERAMIC CHIP 0.33uF 10%	16V
		< DIODE >		C34	1-163-125-00	CERAMIC CHIP 220PF 5%	50V
D9	8-719-079-31	LED SLI-342YCT32-RS (B)		C35	1-163-009-11	CERAMIC CHIP 0.001uF 10%	50V
D10	8-719-079-31	LED SLI-342YCT32-RS (A)		C37	1-163-021-91	CERAMIC CHIP 0.01uF 10%	50V
*****				C38	1-163-259-91	CERAMIC CHIP 220PF 5%	50V
* A-3683-190-A		MAIN BOARD, COMPLETE *****		C39	1-163-009-11	CERAMIC CHIP 0.001uF 10%	50V
		< FILTER >		C100	1-163-133-00	CERAMIC CHIP 470PF 5%	50V
BPF1	1-236-022-11	FILTER, BAND PASS < CAPACITOR >		C101	1-163-133-00	CERAMIC CHIP 470PF 5%	50V
C3	1-163-251-11	CERAMIC CHIP 100PF 5% 50V		C102	1-163-133-00	CERAMIC CHIP 470PF 5%	50V
C4	1-163-141-00	CERAMIC CHIP 0.001uF 5% 50V		C103	1-163-133-00	CERAMIC CHIP 470PF 5%	50V
C5	1-163-021-91	CERAMIC CHIP 0.01uF 10% 50V		C104	1-163-009-11	CERAMIC CHIP 0.001uF 10%	50V
C6	1-163-227-11	CERAMIC CHIP 10PF 0.50PF 50V		C105	1-163-133-00	CERAMIC CHIP 470PF 5%	50V
C7	1-163-141-00	CERAMIC CHIP 0.001uF 5% 50V		C106	1-163-133-00	CERAMIC CHIP 470PF 5%	50V
				C107	1-163-133-00	CERAMIC CHIP 470PF 5%	50V
				C108	1-126-916-11	ELECT 1000uF 20%	6.3V
				C109	1-163-038-91	CERAMIC CHIP 0.1uF	25V
				C110	1-164-346-11	CERAMIC CHIP 1uF	16V
				C111	1-163-108-00	CERAMIC CHIP 43PF 5%	50V
				C112	1-163-233-11	CERAMIC CHIP 18PF 5%	50V
				C113	1-163-021-91	CERAMIC CHIP 0.01uF 10%	50V
				C114	1-163-038-91	CERAMIC CHIP 0.1uF	25V
				C115	1-163-038-91	CERAMIC CHIP 0.1uF	25V
				C116	1-163-038-91	CERAMIC CHIP 0.1uF	25V
				C118	1-163-022-00	CERAMIC CHIP 0.012uF 10%	50V

MAIN

Ref. No.	Part No.	Description	Remarks	Ref. No.	Part No.	Description	Remarks
C119	1-163-021-91	CERAMIC CHIP	0.01uF 10% 50V	JC15	1-216-296-91	SHORT	0
C151	1-163-021-91	CERAMIC CHIP	0.01uF 10% 50V	JC16	1-216-296-91	SHORT	0
C152	1-163-021-91	CERAMIC CHIP	0.01uF 10% 50V	JC17	1-216-296-91	SHORT	0
C153	1-163-021-91	CERAMIC CHIP	0.01uF 10% 50V	JC18	1-216-296-91	SHORT	0
C154	1-163-021-91	CERAMIC CHIP	0.01uF 10% 50V	JC19	1-216-296-91	SHORT	0
C155	1-163-021-91	CERAMIC CHIP	0.01uF 10% 50V	JC20	1-216-296-91	SHORT	0
C156	1-126-927-11	ELECT	2200uF 20% 10V	JC21	1-216-296-91	SHORT	0
C157	1-104-666-11	ELECT	220uF 20% 25V	JC22	1-216-296-91	SHORT	0
C158	1-126-934-11	ELECT	220uF 20% 10V	JC23	1-216-295-91	SHORT	0
< FILTER >				JC24	1-216-295-91	SHORT	0
* CF1	1-577-319-11	FILTER, CERAMIC	450kHz	JC25	1-216-296-91	SHORT	0
CF2	1-579-632-41	FILTER, CERAMIC	10.7MHz	JC27	1-216-295-91	SHORT	0
CF3	1-579-632-41	FILTER, CERAMIC	10.7MHz	JC100	1-216-295-91	SHORT	0
< CONNECTOR >				JC103	1-216-295-91	SHORT	0
CN2	1-568-269-11	SOCKET, CONNECTOR	3P	JC105	1-216-295-91	SHORT	0
* CN150	1-568-270-11	SOCKET, CONNECTOR	4P	JC107	1-216-295-91	SHORT	0
* CN201	1-568-271-11	SOCKET, CONNECTOR	5P	JC110	1-216-296-91	SHORT	0
< TRIMMER >				JC111	1-216-296-91	SHORT	0
CT1	1-141-601-21	CAP, ADJ		JC114	1-216-296-91	SHORT	0
CT3	1-141-601-21	CAP, ADJ		JC115	1-216-296-91	SHORT	0
< DIODE >				JC116	1-216-296-91	SHORT	0
D2	8-713-100-12	DIODE	1T362	JC117	1-216-296-91	SHORT	0
D3	8-713-100-12	DIODE	1T362	JC121	1-216-296-91	SHORT	0
D4	8-719-072-59	DIODE	SVC347S-TL	JC122	1-216-296-91	SHORT	0
D5	8-719-079-31	LED	SLI-342YCT32-RS (BACK LIGHT)	JC122	1-216-296-91	SHORT	0
D6	8-719-079-31	LED	SLI-342YCT32-RS (BACK LIGHT)	JC123	1-216-296-91	SHORT	0
D7	8-719-079-31	LED	SLI-342YCT32-RS (BACK LIGHT)	JC124	1-216-296-91	SHORT	0
D8	8-719-079-31	LED	SLI-342YCT32-RS (BACK LIGHT)	JC125	1-216-296-91	SHORT	0
D100	8-719-074-44	DIODE	1SS120RX	JC126	1-216-296-91	SHORT	0
D101	8-719-074-44	DIODE	1SS120RX	JC127	1-216-296-91	SHORT	0
D151	8-719-074-44	DIODE	1SS120RX	JC128	1-216-296-91	SHORT	0
D152	8-719-031-85	DIODE	1N4002L	JC129	1-216-296-91	SHORT	0
D153	8-719-031-85	DIODE	1N4002L	JC130	1-216-295-91	SHORT	0
D154	8-719-031-85	DIODE	1N4002L	JC131	1-216-296-91	SHORT	0
D155	8-719-031-85	DIODE	1N4002L	JC132	1-216-295-91	SHORT	0
D156	8-719-976-99	DIODE	DTZ5.1B	JC133	1-216-296-91	SHORT	0
< IC >				JC134	1-216-295-91	SHORT	0
IC1	8-752-050-16	IC	CXA1019M	JC135	1-216-296-91	SHORT	0
IC100	8-759-664-99	IC	uPD17072GB-019-1A7	JC136	1-216-296-91	SHORT	0
< JUMPER >				JC151	1-216-296-91	SHORT	0
JC2	1-216-295-91	SHORT	0	JC301	1-216-296-91	SHORT	0
JC3	1-216-296-91	SHORT	0	< COIL >			
JC4	1-216-296-91	SHORT	0	L1	1-406-485-11	COIL (OSC)	
JC5	1-216-295-91	SHORT	0	L2	1-414-690-11	INDUCTOR	82nH
JC6	1-216-295-91	SHORT	0	L3	1-406-545-11	COIL, AIR-CORE	
JC8	1-216-296-91	SHORT	0	L4	1-402-616-11	ANTENNA, FERRITE-ROD (MW)	
JC9	1-216-296-91	SHORT	0	< LIQUID CRYSTAL DISPLAY >			
JC10	1-216-295-91	SHORT	0	LCD100	1-803-947-11	DISPLAY PANEL, LIQUID CRYSTAL	
JC12	1-216-296-91	SHORT	0	< IC LINK >			
JC14	1-216-296-91	SHORT	0	PS150	1-533-588-31	LINK, IC	
< TRANSISTOR >				Q2	8-729-102-07	TRANSISTOR	2SC2223-F13
Q3	1-801-806-11	TRANSISTOR	DTC144EKA-T146	Q6	8-729-216-22	TRANSISTOR	2SA1162-G
Q6	8-729-216-22	TRANSISTOR	2SA1162-G	Q7	8-729-120-28	TRANSISTOR	2SC1623-L5L6
Q7	8-729-120-28	TRANSISTOR	2SC1623-L5L6	Q8	8-729-120-28	TRANSISTOR	2SC1623-L5L6
Q8	8-729-120-28	TRANSISTOR	2SC1623-L5L6				

Ref. No.	Part No.	Description	Remarks	Ref. No.	Part No.	Description	Remarks
Q9	8-729-120-28	TRANSISTOR	2SC1623-L5L6	R120	1-216-238-91	RES-CHIP 47K	5% 1/8W
Q10	8-729-120-28	TRANSISTOR	2SC1623-L5L6	R151	1-216-198-91	RES-CHIP 1K	5% 1/8W
Q100	8-729-216-22	TRANSISTOR	2SA1162-G	R152	1-216-041-00	METAL CHIP 470	5% 1/10W
Q101	1-801-806-11	TRANSISTOR	DTC144EKA-T146	R153	1-216-254-00	RES-CHIP 220K	5% 1/8W
Q151	8-729-840-00	TRANSISTOR	2SD400-E			< SWITCH >	
		< RESISTOR >		S1	1-692-181-31	SWITCH, SLIDE (BRIGHTNESS)	
R3	1-216-097-91	RES-CHIP	100K	5%	1/10W	< TRANSFORMER >	
R5	1-216-049-91	RES-CHIP	1K	5%	1/10W		
R6	1-216-057-00	METAL CHIP	2.2K	5%	1/10W	T1	1-404-790-11
R7	1-216-037-00	METAL CHIP	330	5%	1/10W		
R9	1-216-097-91	RES-CHIP	100K	5%	1/10W		
		< VARIABLE RESISTOR >					
R10	1-216-089-91	RES-CHIP	47K	5%	1/10W	VR1	1-228-790-00
R11	1-216-073-00	METAL CHIP	10K	5%	1/10W		
R12	1-216-037-00	METAL CHIP	330	5%	1/10W		
R13	1-216-121-91	RES-CHIP	1M	5%	1/10W		
R14	1-216-029-00	METAL CHIP	150	5%	1/10W		
		< FLAT CABLE >					
R17	1-216-186-00	RES-CHIP	330	5%	1/8W	W1	1-501-907-21
R19	1-216-073-00	METAL CHIP	10K	5%	1/10W		
R20	1-216-105-91	RES-CHIP	220K	5%	1/10W		
R21	1-216-222-00	RES-CHIP	10K	5%	1/8W		
R22	1-216-246-00	RES-CHIP	100K	5%	1/8W		
		< VIBRATOR >					
						X100	1-767-517-11
							VIBRATOR, CRYSTAL 75kHz

						*	1-676-851-11
							POWER BOARD

						*	1-535-771-11
							TERMINAL
							< TRANSFORMER >
						△ T150	1-435-504-11
							TRANSFORMER, POWER

							MISCELLANEOUS

						18	1-553-856-00
							SWITCH, KEY BOARD
						SP1	1-504-748-21
							SPEAKER (6.6cm)
						△ P150	1-790-431-11
							CORD, POWER

							ACCESSORIES & PACKING MATERIALS

						3-046-172-11	MANUAL, INSTRUCTION
							(ENGLISH, FRENCH, GERMAN, DUTCH)
R113	1-216-113-00	METAL CHIP	470K	5%	1/10W		
R114	1-216-113-00	METAL CHIP	470K	5%	1/10W		
R117	1-216-089-91	RES-CHIP	47K	5%	1/10W		
R118	1-216-089-91	RES-CHIP	47K	5%	1/10W		
R119	1-216-089-91	RES-CHIP	47K	5%	1/10W		

The components identified by mark △ or dotted line with mark △ are critical for safety. Replace only with part number specified.

