

ICF-C250/C250SY

SERVICE MANUAL

US Model
ICF-C250SY

AEP Model
E Model
ICF-C250

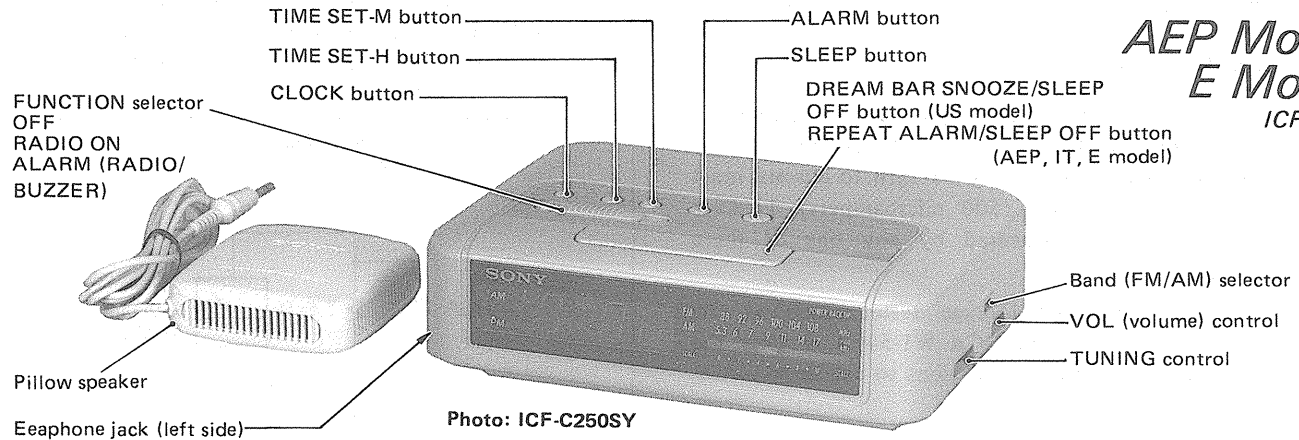

SPECIFICATIONS

Frequency range	FM	AM
US model	87.6–108MHz	530–1,710kHz
AEP, E model	87.6–107.5MHz	531–1,602kHz
IT model	87.5–108MHz	526.5–1,606.5kHz

Antenna	FM: AC power cord antenna AM: Built-in ferrite bar antenna
Speaker	Approx. 6.6 cm (2 5/8 inches) dia.
Output	Earphone jack (minijack)
Power output	100 mW (at 10% harmonic distortion)
Power requirements	120 V AC, 60 Hz (US model) 220 V AC, 50 Hz (AEP, IT, E model) For the power backup function: 9 V DC, one 6F22 battery
Battery life	Approx. 80 hours, using Sony battery S-006P (U)
Dimensions	Approx. 181.5 × 59 × 144 mm (w/h/d) (7 1/4 × 2 3/8 × 5 3/4 inches) incl. projecting parts and controls
Weight	Approx. 520 g (1 lb 3 oz) not incl. battery
Accessory supplied	Pillow Speaker (1) (ICF-C250SY)

Design and specifications subject to change without notice.



US model	AEP, IT, E model
12-hours system	24-hour system
AM 12:00 = midnight PM 12:00 = noon	0:00 = midnight 12:00 = noon

IT model: Italian model

FEATURES

- Electronic digital alarm clock and sleep timer are combined.
- Two wake-up modes available: radio or buzzer alarm.
- DREAM BAR SNOOZE/SLEEP OFF bar (US model), REPEAT ALARM/SLEEP OFF bar (AEP, IT, E model), operable with a feather-light touch, offers two functions: snooze alarm and sleep timer turn off.
- Power back-up function to keep the clock operating during a power interruption, using an optional 6F22 battery.

SAFETY-RELATED COMPONENT WARNING!!

COMPONENTS IDENTIFIED BY MARK  OR DOTTED LINE WITH MARK  ON THE SCHEMATIC DIAGRAMS AND IN THE PARTS LIST ARE CRITICAL TO SAFE OPERATION. REPLACE THESE COMPONENTS WITH SONY PARTS WHOSE PART NUMBERS APPEAR AS SHOWN IN THIS MANUAL OR IN SUPPLEMENTS PUBLISHED BY SONY.

FM/AM DIGITAL CLOCK RADIO
SONY[®]

SAFETY CHECK-OUT

After correcting the original service problem, perform the following safety check before releasing the set to the customer:

Check the antenna terminals, metal trim, "metallized" knobs, screws, and all other exposed metal parts for AC leakage. Check leakage as described below.

LEAKAGE TEST

The AC leakage from any exposed metal part to earth ground and from all exposed metal parts to any exposed metal part having a return to chassis, must not exceed 0.5 mA (500 microampers). Leakage current can be measured by any one of three methods.

1. A commercial leakage tester, such as the Simpson 229 or RCA WT-540A. Follow the manufacturers' instructions to use these instruments.
2. A battery-operated AC milliammeter. The Data Precision 245 digital multimeter is suitable for this job.

3. Measuring the voltage drop across a resistor by means of a VOM or battery-operated AC voltmeter. The "limit" indication is 0.75 V, so analog meters must have an accurate low-voltage scale. The Simpson 250 and Sanwa SH-63Trd are examples of a passive VOM that is suitable. Nearly all battery operated digital multimeters that have a 2 V AC range are suitable. (See Fig. A)

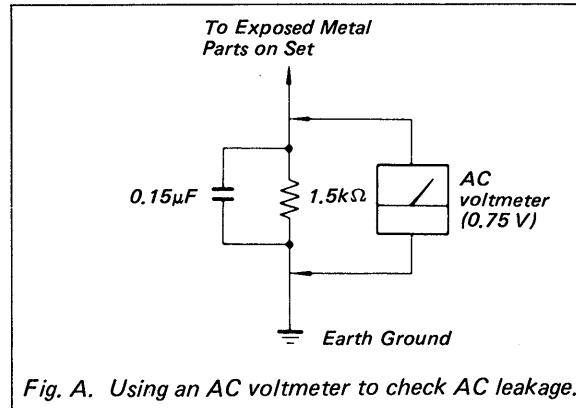

SECTION 1 GENERAL

1-1. MODEL IDENTIFICATION

—Model Number Label—
Carved on lower cabinet

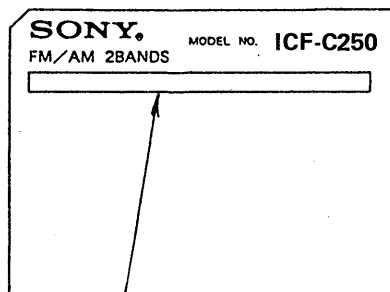

US model: AC: 120V 60Hz 5W
AEP, IT, E model: AC: 220V ~ 50Hz 5W

1-2. MAIN BOARD REMOVAL

- 1 Turn TUNING knob fully clockwise.
- 2 Remove screw (+B 2.6X5)
- 3 Release fook.
- 4 Remove main board pressing down TUNING knob.

Note: When installing main board, align shaft of VOL knob with a hole of adjustable resistor.

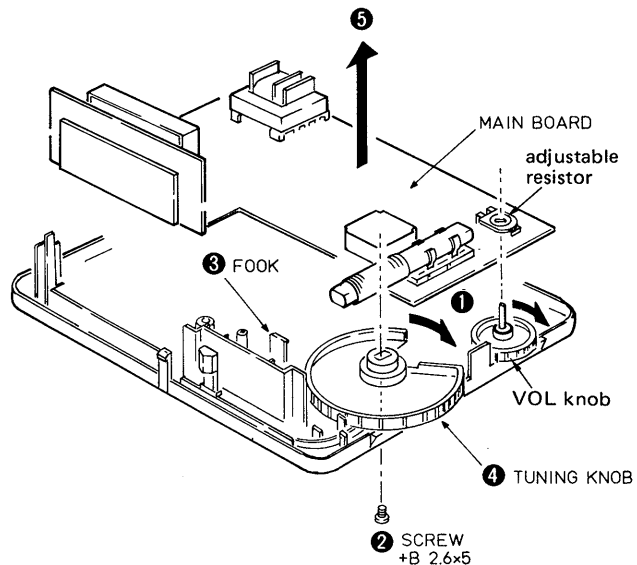

13. FUNCTION OF CONTROLS

How to Set the Clock

Example: To set to 8:15 AM (12-hours system)

- 1 Plug in the unit.**
- 2 Set the hour.**
- 3 Set the minute.**

Release the CLOCK button just at 8:15 AM. The clock will begin to operate.

- Each press on the H or M button advances the displayed number by one.
- The minute digits advance to "00" after "59". The hour digits do not advance by pressing M button.

To adjust the time exactly to the second, release the H or M button simultaneously with the radio or telephone time signal.

How to Use the Supplied Pillow Speaker

When connecting a pillow speaker to the ICF-C250SY, the radio or alarm (radio or buzzer) can be heard only from the pillow speaker. Adjust the volume with VOL on the unit.

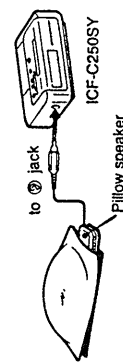

You can also connect an optional earphone to the Ⓣ jack.

Radio Operation

- 1 Turn on the radio.**
- 2 Turn VOL to get sound.**
- 3 Select the desired band.**
- 4 Tune in the desired station.**

To stop the radio

To improve the radio reception
FM: Extend the AC power cord fully.

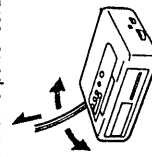

AM: Rotate the unit horizontally.

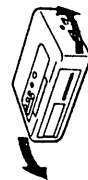

How to Set the Alarm (RADIO or BUZZER)

For radio alarm, first tune in the desired station and adjust the volume.
Example: To set the alarm time to 7:15 AM (12-hours system)

- 1 Set the hour.**
- 2 Set the minute.**
- 3 Set the function selector.**

The desired alarm sound will come on at the preset time, and shut off automatically after 119 minutes.

If you want to doze a few more minutes

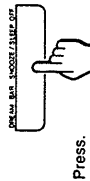

The alarm sound will be silenced, but will automatically come on again after about nine minutes. You can repeat this snooze function as many times as you like within 119 minutes from the preset alarm time.

To completely cancel the alarm mode

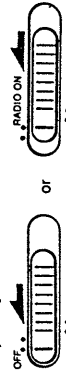

To set the alarm time to the same time again, repeat step 3 above.

The volume of the alarm sound
The radio volume can be adjusted.
The buzzer volume is fixed.

To check the preset time

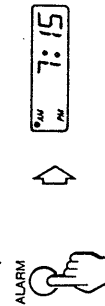

How to Set the Sleep Timer

- 1 While listening to the radio, set the function selector to OFF.**
- 2 Press SLEEP.**

To turn off the radio before the preset time

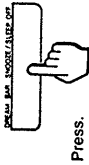

Every time the SLEEP button is pressed, the sleep timer is reset to 59 minutes.

If the preset alarm time comes while the sleep timer is operating

The alarm buzzer will not sound.

SECTION 2 ELECTRICAL ADJUSTMENTS

RADIO SECTION

FM Section

FM rf signal generator

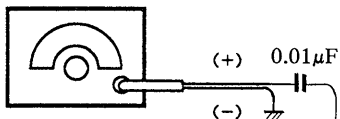

±22.5 kHz frequency deviation by 400 Hz signal
output level : as low as possible

AM Section

AM rf signal generator

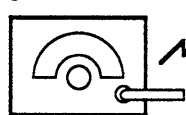

400Hz, 30% AM modulation
Output level : as low as possible

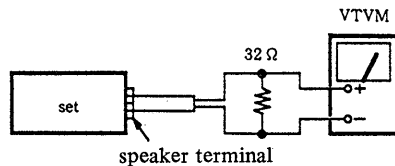

- Repeat the procedures in each adjustment several times, and the frequency coverage and tracking adjustments should be finally done by the trimmer capacitors.

FM FREQUENCY COVERAGE ADJUSTMENT	
Adjust for a maximum reading on VTVM.	
L4	86.5 (87.35)<87.3>MHz
CT2	109.5 (108.05)<108.3>MHz

FM TRACKING ADJUSTMENT	
Adjust for a maximum reading on VTVM.	
L5, L6	86.5 (87.35)<87.3>MHz
CT1	109.5 (108.05)<108.3>MHz

(): AEP, E model
< >: IT model

AM IF ALIGNMENT	
Adjust for a maximum reading on VTVM.	
T2	
455kHz	

AM FREQUENCY COVERAGE ADJUSTMENT	
Adjust for a maximum reading on VTVM.	
L3	520 (520)<516.5>kHz
CT4	1,750 (1,650)<1,631.5>kHz

AM TRACKING ADJUSTMENT	
Adjust for a maximum reading on VTVM.	
L7	600kHz
CT3	1,400kHz

【MAIN BOARD】 - component side -

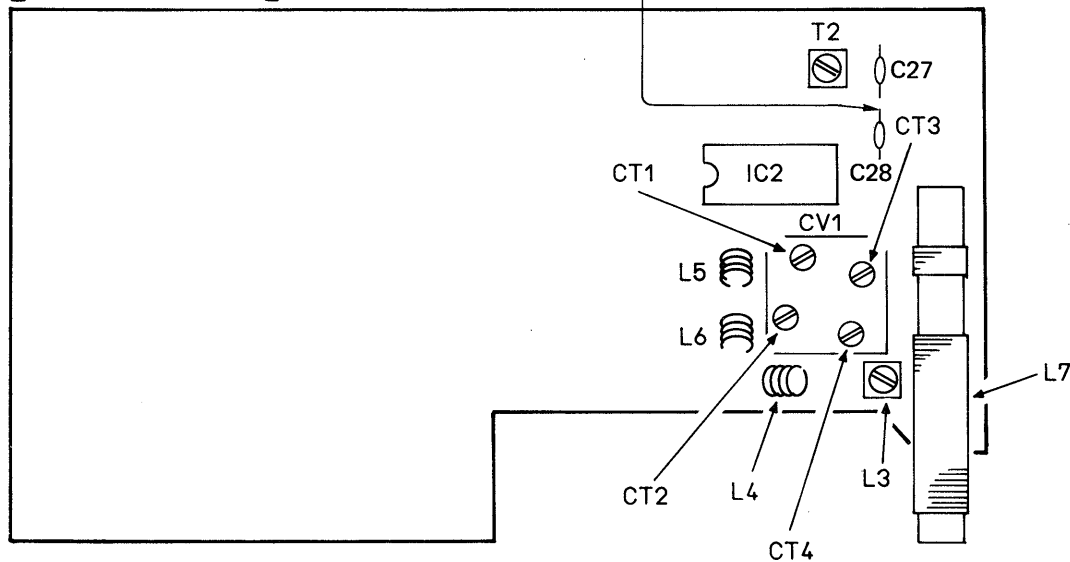

SECTION 3 DIAGRAMS

3-1. PRINTED WIRING BOARDS

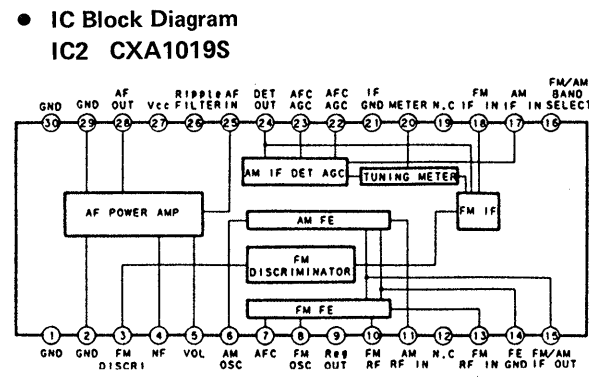
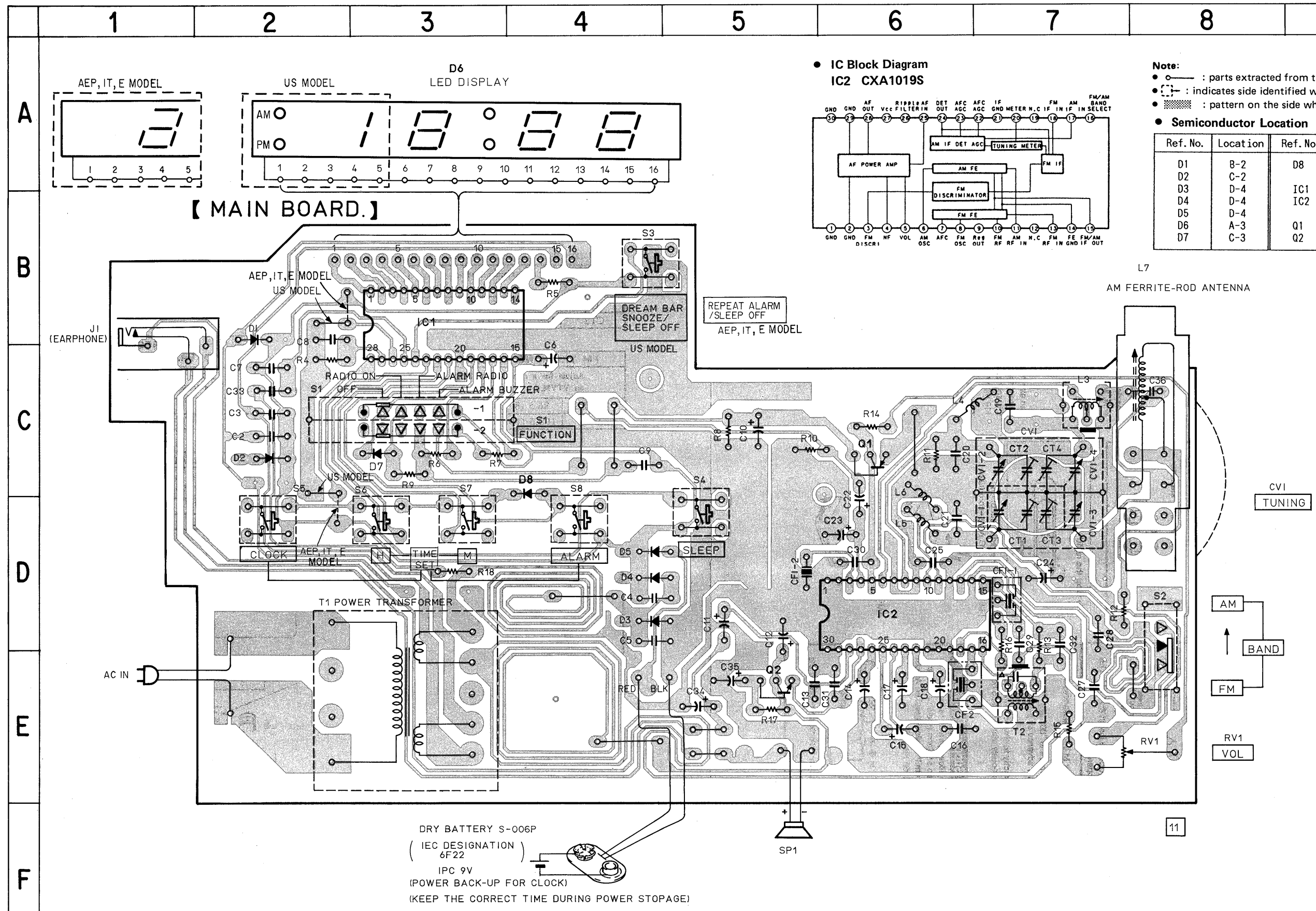

Note:
 ● — : parts extracted from the component side.
 ● — : indicates side identified with part number.
 ● — : pattern on the side which is seen.

● Semiconductor Location

Ref. No.	Location	Ref. No.	Location
D1	B-2	D8	C-4
D2	C-2	IC1	B-3
D3	D-4	IC2	D-6
D4	D-4		
D5	D-4		
D6	A-3	Q1	C-6
D7	C-3	Q2	E-5

【 MAIN BOARD. 】

L7
AM FERRITE-ROD ANTENNA

CV1
TUNING

AM
↑
BAND
FM
RV1
VOL

DRY BATTERY S-006P
(IEC DESIGNATION)
6F22
IPC 9V
(POWER BACK-UP FOR CLOCK)
(KEEP THE CORRECT TIME DURING POWER STOPAGE)

3-2. SCHEMATIC DIAGRAM

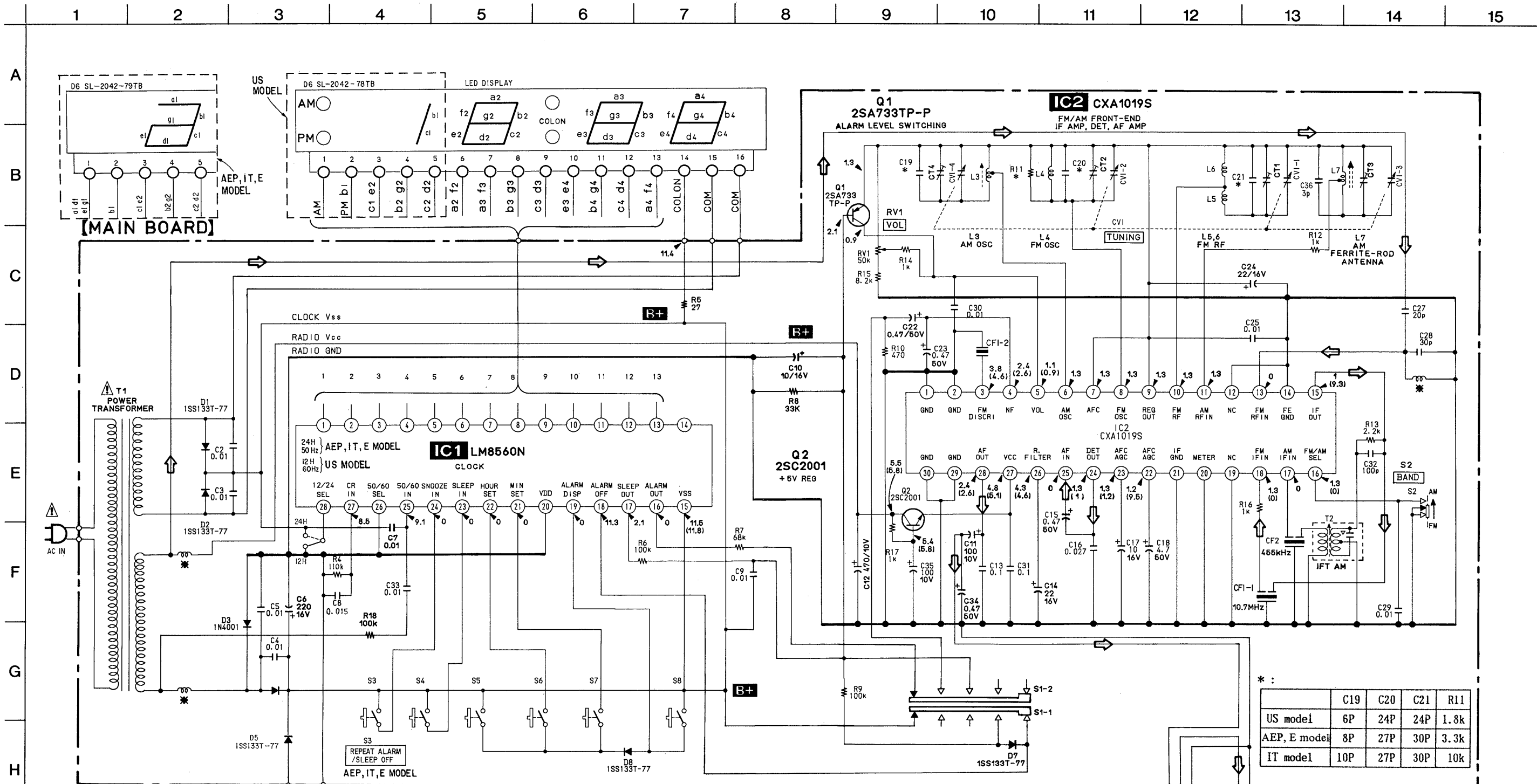

* :

	C19	C20	C21	R11
US model	6P	24P	24P	1.8k
AEP, E model	8P	27P	30P	3.3k
IT model	10P	27P	30P	10k

• SEMICONDUCTOR LEAD LAYOUTS

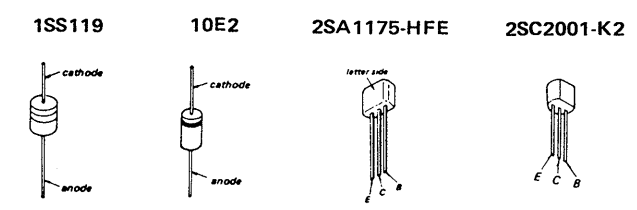

Note: The components identified by mark or dotted line with mark are critical for safety. Replace only with part number specified.

- IT model: Italian model.
- : Printed pattern functions as a kind of coil.
- All capacitors are in μF unless otherwise noted. pF: μpF 50WV or less are not indicated except for electrolytics and tantalums.
- All resistors are in Ω and $\frac{1}{4}\text{W}$ or less unless otherwise specified.
- Δ : internal component.
- **B+**: B+ lines.
- Voltage and waveforms are dc with respect to ground

- under detuned conditions.
- no mark: FM
- (): AM
- Voltages are taken with a VOM. (input impedance 10 M Ω) Voltage variations may be noted due to normal production tolerances.
- Signal path.
- : FM

SECTION 4 EXPLODED VIEWS

NOTE:

- The mechanical parts with no reference number in the exploded views are not supplied.
- The construction parts of an assembled part are indicated with a collation number in the remark column.
- Items marked "★" are not stocked since they are seldom required for routine service. Some delay should be anticipated when ordering these items.

- Due to standardization, parts with part number suffix -XX and -X may be different from the parts specified in the components used on the set.
- Color Indication of Appearance Parts Example:
(RED) ... KNOB, BALANCE (WHITE)

↑ Cabinet's Color ↑ Parts Color

The components identified by mark or dotted line with mark are critical for safety. Replace only with part number specified.

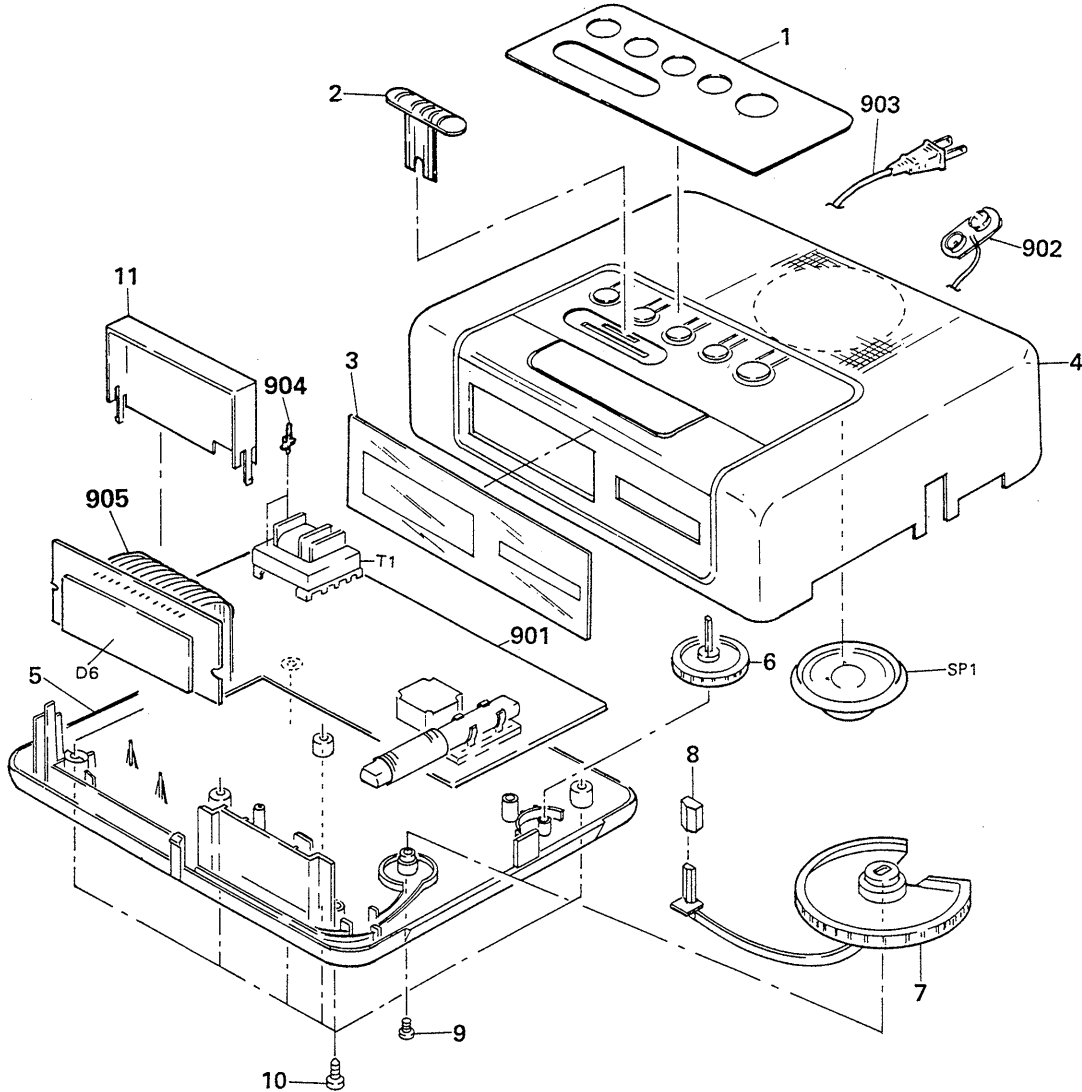

No.	Part No.	Description	Remarks
1	3-902-093-41	(BROWN)...PLATE, ORNAMENTAL (GRAIN)	
	3-902-093-51	(WHITE)...PLATE, ORNAMENTAL (LIGHT GRAY)	
	3-902-093-71	(BLACK)...PLATE, ORNAMENTAL (BLACK)	
2	3-902-092-01	(WHITE)...KNOB (FUNCTION)	
	3-902-092-31	(BLACK)...KNOB (FUNCTION)	
	3-902-092-42	(BROWN)...KNOB (FUNCTION)	
3	3-902-090-02	(US).....SCALE, DIAL	
	3-902-090-11	(AEP,E)...SCALE, DIAL	
	3-902-090-31	(IT).....SCALE, DIAL	
4	3-902-471-01	(WHITE)...CABINET (UPPER)	
	3-902-471-11	(BROWN)...CABINET (UPPER)	
	3-902-471-31	(BLACK)...CABINET (UPPER)	
5	3-902-470-31	(BROWN)...CABINET (LOWER)	
	3-902-470-41	(WHITE)...CABINET (LOWER)	
	3-902-470-61	(BLACK)...CABINET (LOWER)	
6	3-902-091-01	(BROWN,BLACK)...KNOB (VOL)(GRAY)	
	3-902-091-11	(WHITE).....KNOB (VOL)(LIGHT GRAY)	
7	3-902-474-01	(BROWN,BLACK)...KNOB (TUNING)(GRAY)	
	3-902-474-11	(WHITE).....KNOB (TUNING)(LIGHT GRAY)	

No.	Part No.	Description	Remarks
8	*3-902-463-01	CAP (POINTER)	
9	7-621-775-20	SCREW +B 2.6X5	
10	7-685-648-79	SCREW +BTP 3X12 TYPE2 N-S	
11	3-902-094-02	(US).....STOPPER (DREAM BAR)	
	3-902-094-02	(AEP,IT,E)...STOPPER (REPEAT ALARM BAR)	
901	*A-3615-363-A	(C250:IT).....MOUNTED PCB, MAIN	
	*A-3615-364-A	(C250:AEP,E)...MOUNTED PCB, MAIN	
	*A-3615-346-A	(C250SY).....MOUNTED PCB, MAIN	
902	1-535-253-00	SNAP, BATTERY	
903	▲1-555-795-00	(AEP,IT,E)...CORD, POWER	
	▲1-557-102-31	(US).....CORD, POWER	
904	1-535-476-11	(AEP,IT,E)...TERMINAL	
905	*1-575-159-11	CORD, CONNECTON	
D6	1-808-653-11	(US).....LED BLOCK SL-2042-78TB	
D6	1-808-653-21	(AEP,IT,E)...LED BLOCK SL-2042-79TB	
SP1	1-503-082-00	SPEAKER	
T1	▲1-449-801-11	(US).....TRANSFORMER, POWER	
T1	▲1-449-940-11	(AEP,IT,E)...TRANSFORMER, POWER	

SECTION 5 ELECTRICAL PARTS LIST

NOTE:

- Due to standardization, replacements in the parts list may be different from the parts specified in the diagrams or the components used on the set.
- Items marked "★" are not stocked since they are seldom required for routine service. Some delay should be anticipated when ordering these items.
- If there are two or more same circuits in a set such as a stereophonic machine, only typical circuit parts may be indicated and capacitors and resistors in other same circuits may be omitted.

CAPACITORS:

MF: μ F, PF: μ MF.

RESISTORS

- All resistors are in ohms.
- F: nonflammable

COILS

- MMH: mH, UH: μ H

SEMICONDUCTORS

In each case, U: μ , for example:

UA....: μ A...., UPA....: μ PA....,
UPC....: μ PC, UPD....: μ PD....

The components identified by mark Δ or dotted line with mark Δ are critical for safety.
Replace only with part number specified.

Ref.No.	Part No.	Description
901	*A-3615-363-A	(C250:IT).....MOUNTED PCB, MAIN
	*A-3615-364-A	(C250:AEP,E)...MOUNTED PCB, MAIN
	*A-3615-346-A	(C250SY).....MOUNTED PCB, MAIN
902	1-535-253-00	SNAP, BATTERY
903	Δ 1-555-795-00	(AEP,IT,E)...CORD, POWER
	Δ 1-557-102-31	(US).....CORD, POWER
904	1-535-476-11	(AEP,IT,E)...TERMINAL
905	*1-575-159-11	CORD, CONNECTION
C2	1-101-004-00	CERAMIC 0.01MF 50V
C3	1-101-004-00	CERAMIC 0.01MF 50V
C4	1-101-004-00	CERAMIC 0.01MF 50V
C5	1-101-004-00	CERAMIC 0.01MF 50V
C6	1-124-120-11	ELECT 220MF 20% 16V
C7	1-101-004-00	CERAMIC 0.01MF 50V
C8	1-130-485-00	MYLAR 0.015MF 5% 50V
C9	1-161-379-00	CERAMIC 0.01MF 30% 16V
C10	1-123-356-00	ELECT 10MF 20% 16V
C11	1-126-101-11	ELECT 100MF 20% 10V
C12	1-124-472-11	ELECT 470MF 20% 10V
C13	1-162-851-11	CERAMIC 0.1MF 20% 16V
C14	1-123-330-00	ELECT 22MF 20% 16V
C15	1-123-379-00	ELECT 0.47MF 20% 50V
C16	1-161-056-00	CERAMIC 0.027MF 10% 25V
C17	1-123-356-00	ELECT 10MF 20% 16V
C18	1-123-369-00	ELECT 4.7MF 20% 50V
C19	1-102-943-00	(US).....CERAMIC 6PF 0.5PF 50V
C19	1-102-945-00	(AEP,E)...CERAMIC 8PF 0.5PF 50V
C19	1-102-947-00	(IT).....CERAMIC 10PF 0.5PF 50V
C20	1-102-960-00	(US)...CERAMIC 24PF 5% 50V
C20	1-102-961-00	(AEP,IT,E)... CERAMIC 27PF 5% 50V
C21	1-102-960-00	(US)...CERAMIC 24PF 5% 50V
C21	1-102-962-00	(AEP,IT,E)... CERAMIC 30PF 5% 50V
C22	1-123-379-00	ELECT 0.47MF 20% 50V
C23	1-123-379-00	ELECT 0.47MF 20% 50V
C24	1-123-330-00	ELECT 22MF 20% 16V
C25	1-101-004-00	CERAMIC 0.01MF 50V
C27	1-102-958-00	CERAMIC 20PF 5% 50V
C28	1-102-962-00	CERAMIC 30PF 5% 50V
C29	1-101-004-00	CERAMIC 0.01MF 50V
C30	1-101-004-00	CERAMIC 0.01MF 50V
C31	1-162-851-11	CERAMIC 0.1MF 20% 16V
C32	1-102-973-00	CERAMIC 100PF 5% 50V
C33	1-101-004-00	CERAMIC 0.01MF 50V
C34	1-123-379-00	ELECT 0.47MF 20% 50V
C35	1-126-101-11	ELECT 100MF 20% 10V
C36	1-102-936-00	CERAMIC 3PF 0.25PF 50V
CF1	1-567-166-00	FILTER, CERAMIC
CF2	1-577-072-11	FILTER, CERAMIC
CT1-4	1-151-614-11	(AEP,IT,E)...CAP, VARIABLE
CV1		(US)...CAP, VARIABLE
CT1-4	1-151-628-11	(US)...CAP, VARIABLE
CV1		(US)...CAP, VARIABLE
D1	8-719-911-19	DIODE 1SS119
D2	8-719-911-19	DIODE 1SS119
D3	8-719-200-02	DIODE 10E2
D4	8-719-911-19	DIODE 1SS119
D5	8-719-911-19	DIODE 1SS119
D6	1-808-653-11	(US).....LED BLOCK SL-2042-78TB
D6	1-808-653-21	(AEP,IT,E)...LED BLOCK SL-2042-79TB
D7	8-719-911-19	DIODE 1SS119
D8	8-719-911-19	DIODE 1SS119

Ref.No.	Part No.	Description
IC1	8-759-821-46	IC LM8560N
IC2	8-752-035-29	IC CXAI019S
J1	1-563-836-21	JACK (EARPHONE)
L3	1-406-150-11	COIL, MW OSC
L4	*1-405-962-00	(AEP,E)...COIL, FM OSC
L4	*1-422-130-00	(US).....COIL, FM OSC
L4	1-459-815-11	(IT).....COIL (WITH CORE), FM OSC
L5	*1-422-291-11	COIL, AIR-CORE
L6	*1-422-291-11	COIL, AIR-CORE
L7	1-402-405-11	(AEP,IT,E)...ANTENNA, FERRITE-ROD (MW)
L7	1-402-413-21	(US).....ANTENNA, FERRITE-ROD (MW)
Q1	8-729-119-76	TRANSISTOR 2SA1175-HFE
Q2	8-729-100-13	TRANSISTOR 2SC2001-K2
R4	1-247-880-11	CARBON 110K 5% 1/4W
R5	1-249-398-11	CARBON 27 5% 1/4W
R6	1-249-441-11	CARBON 100K 5% 1/4W
R7	1-249-439-11	CARBON 68K 5% 1/4W
R8	1-249-435-11	CARBON 33K 5% 1/4W
R9	1-249-441-11	CARBON 100K 5% 1/4W
R10	1-249-413-11	CARBON 470 5% 1/4W
R11	1-249-420-11	(US).....CARBON 1.8K 5% 1/4W
R11	1-249-423-11	(AEP,E)...CARBON 3.3K 5% 1/4W
R11	1-249-429-11	(IT).....CARBON 10K 5% 1/4W
R12	1-249-417-11	CARBON 1K 5% 1/4W
R13	1-249-421-11	CARBON 2.2K 5% 1/4W
R14	1-249-417-11	CARBON 1K 5% 1/4W
R15	1-249-428-11	CARBON 8.2K 5% 1/4W
R16	1-249-417-11	CARBON 1K 5% 1/4W
R17	1-249-417-11	CARBON 1K 5% 1/4W
R18	1-249-441-11	CARBON 100K 5% 1/4W
RV1	1-228-790-00	RES, VAR, CARBON 50K (VOL)
S1	1-572-023-11	SWITCH, SLIDE (FUNCTION)
S2	1-552-370-31	SWITCH, SLIDE (BAND)
S3	1-553-856-00	(US)....SWITCH, KEY BOARD (DREAM BAR SNOOZE/SLEEP OFF)
S3	1-553-856-00	(AEP,IT,E)...SWITCH, KEY BOARD (REPEAT ALARM/SLEEP OFF)
S4	1-553-856-00	SWITCH, KEY BOARD (SLEEP)
S5	1-553-856-00	SWITCH, KEY BOARD (LOCK)
S6	1-553-856-00	SWITCH, KEY BOARD (TIME SET-H)
S7	1-553-856-00	SWITCH, KEY BOARD (TIME SET-M)
S8	1-553-856-00	SWITCH, KEY BOARD (ALARM)
SP1	1-503-082-00	SPEAKER
T1	Δ 1-449-801-11	(US).....TRANSFORMER, POWER
T1	Δ 1-449-940-11	(AEP,IT,E)...TRANSFORMER, POWER
T2	1-404-790-11	TRANSFORMER, IF

ACCESSORY & PACKING MATERIAL

- 3-751-271-21 (C250SY)....MANUAL, INSTRUCTION (ENGLISH)
- 3-751-271-41 (C250:AEP,E)...MANUAL, INSTRUCTION (ENGLISH,FRENCH,GERMAN,DUTCH,PORTUGUESE,SPANISH)
- 3-751-271-51 (C250:IT)...MANUAL, INSTRUCTION (ENGLISH,SPANISH,ITALIAN,SWEDISH)
- *3-902-434-02 (C250SY)...INDIVIDUAL CARTON
- *3-902-451-01 (C250)....INDIVIDUAL CARTON
- *3-902-464-01 (C250)....CUSHION
- *3-903-122-01 (C250SY)...CUSHION
- A-3637-027-A (C250SY)...SPEAKER ASSY, PILLOW