

ICF-SW07

AN-LP2

SERVICE MANUAL

Ver 1.0 1999.02

*US Model
Canadian Model
AEP Model
E Model
Tourist Model*



Antenna module



Antenna Controller

AN-LP2



ICF-SW07

SPECIFICATIONS

ICF-SW07

Circuit system

- FM: Super heterodyne
- AM: Dual conversion super heterodyne

Frequency range

- FM: 76–108 MHz
- SW: 1,621–29,999 kHz
- MW: 530–1,620 kHz
- LW: 150–529 kHz

Intermediate frequency

- FM: 10.7 MHz
- SW/MW/LW: 55.845 MHz (1st), 455 kHz (2nd)

Output

- LINE OUT jack (stereo minijack) approx. 245 mV, less than 10 kilohms
- ⌀ (headphones) jack (stereo minijack) 16 ohms

Speaker

- Approx. 40 mm (1⁵/₈ inches) diameter, 8 ohms

Maximum output

- 200 mW (at 10 % harmonic distortion)

Power requirements

- DC 3 V, two R6 (size AA) batteries

External power source

- DC IN 3V jack accepts: supplied AC power adaptor*

Dimensions

- Approx. 135 x 32.5 x 91 mm (w/h/d)(5³/₈ x 1⁵/₁₆ x 3⁵/₈ inches) not incl. projecting parts

Mass

- Approx. 220 g (7.8 oz)
- Approx. 257 g (9.1 oz) incl. batteries

AN-LP2

Power requirements

- DC 3 V, two R6 (size AA) batteries

Dimensions (w/h/d)

Antenna Module

- In use: Approx. 490 x 480 x 17.8 mm (19³/₈ x 19 x 2¹/₃₂ in.)
- Folded: Approx. 205 x 180 x 17.8 mm (8¹/₈ x 7¹/₈ x 2¹/₃₂ in.)

Antenna Controller

- Approx. 120 x 29.5 x 72 mm (4³/₄ x 1³/₁₆ x 2⁷/₈ in.)

Mass

- Antenna Module: approx. 92 g (3.3 oz.)
- Antenna Controller: approx. 144 g (5.1 oz.) incl. batteries

Supplied accessories

- Stereo headphones (1)
- Ear pads (2)
- AC power adaptor (1)*
- AC plug adaptor (1)*
- Active antenna AN-LP2 (1)
- Carrying case for ICF-SW07 (1)
- Carrying case for AN-LP2 (1)
- Wave Handbook (1)
- * Not supplied with the UK, Australian, Chinese (including Hong Kong), and Argentine model.

Your dealer may not handle some of the above listed optional accessories. Please ask your dealer for detailed information on the optional accessories available in your country.

Design and specifications are subject to change without notice.

**FM STEREO/SW/MW/LW
PLL SYNTHESIZED RECEIVER**



SONY®

TABLE OF CONTENTS

Specifications	1
1. SERVICE NOTE	3
2. GENERAL	4
3. DISASSEMBLY	
3-1. Cabinet (Lower), Cabinet ASSY	25
3-2. Chassis ASSY	26
3-3. Main Board	26
3-4. Key Board	27
3-5. Microcomputer Board	27
3-6. Cabinet (Front), Reel ASSY	28
3-7. Cabinet (Rear), Reel Board, Control Board	28
4. ELECTRICAL ADJUSTMENTS	29
5. DIAGRAMS	
5-1. Explanation of IC Terminals	34
5-2. Block Diagrams	37
5-3. Printed Wiring Boards (Main Section)	41
5-4. Schematic Diagram (Main Section)	46
5-5. Printed Wiring Boards (Key Section)	50
5-6. Schematic Diagram (Key Section)	53
5-7. Printed Wiring Boards (Microcomputer Section) ...	55
5-8. Schematic Diagram (Microcomputer Section)	56
5-9. Printed Wiring Boards (Antenna Section)	59
5-10. Schematic Diagram (Antenna Section)	61
6. EXPLODED VIEWS	
6-1. Cabinet Section	64
6-2. Chassis Section	65
6-3. Antenna Controller Section	66
6-4. SW Loop Antenna Section	67
7. ELECTRICAL PARTS LIST	68

Flexible Circuit Board Repairing

- Keep the temperature of the soldering iron around 270°C during repairing.
- Do not touch the soldering iron on the same conductor of the circuit board (within 3 times).
- Be careful not to apply force on the conductor when soldering or unsoldering.

Notes on chip component replacement

- Never reuse a disconnected chip component.
- Notice that the minus side of a tantalum capacitor may be damaged by heat.

SAFETY-RELATED COMPONENT WARNING!!

COMPONENTS IDENTIFIED BY MARK \triangle OR DOTTED LINE WITH MARK \triangle ON THE SCHEMATIC DIAGRAMS AND IN THE PARTS LIST ARE CRITICAL TO SAFE OPERATION. REPLACE THESE COMPONENTS WITH SONY PARTS WHOSE PART NUMBERS APPEAR AS SHOWN IN THIS MANUAL OR IN SUPPLEMENTS PUBLISHED BY SONY.

ATTENTION AU COMPOSANT AYANT RAPPORT À LA SÉCURITÉ!

LES COMPOSANTS IDENTIFIÉS PAR UNE MARQUE \triangle SUR LES DIAGRAMMES SCHÉMATIQUES ET LA LISTE DES PIÈCES SONT CRITIQUES POUR LA SÉCURITÉ DE FONCTIONNEMENT. NE REMPLACER CES COMPOSANTS QUE PAR DES PIÈCES SONY DONT LES NUMÉROS SONT DONNÉS DANS CE MANUEL OU DANS LES SUPPLÉMENTS PUBLIÉS PAR SONY.

SECTION 1 SERVICE NOTE

REPLACING THE SW STATION CALL ROM

The propagation of short-wave radio waves is greatly affected by many causes such as atmospheric phenomenon due to dark spots on the sun, etc.

This makes it necessary for short wave radio broadcast stations to periodically change their broadcast frequencies. This set can be replaced with a new SW STATION CALL ROM to allow changing the broadcast frequencies.

This set came with the latest ROM (Sony) when purchased. The user can later on when needed, purchase the latest updated ROM (F Corp.) version from the F Corporation on referring to the instructions for "Purchasing the Latest SW STATION CALL ROM" which are included with the unit. These ROMs can also be custom made to match the user's particular combination of broadcast station frequencies.

- Identify the 2 different types of ROMs (Sony or F Corp.) as follows.
 - The Sony ROM has no printing on it.
 - The F Corp. ROM is marked with the F Corporation name.
- Servicing is provided for the accessory Sony ROM.
- Only the most recent version is supplied for replacing the Sony ROM.
- A new Sony ROM is issued every year in October and the part No. suffix is also changed.
- A new updated Sony ROM is issued every year so is not usually kept in stock.
- Servicing is not provided for the F Corp. ROM.
- Instruct the user to directly contact the F Corporation when the F Corp. ROM is obviously malfunctioning or defective.

Address
 Mail : F Corporation P.O. Box 816
 Tokyo 100-8692 Japan
 Fax : 81-3-3436-1932
 E-mail : fco@wavehandbook.com

Exchanging the SW STATION CALL ROM

To purchase the newest ROM, refer to "Purchasing the latest SW STATION CALL ROM" and contact F Corporation.

- 1 Hold down the ROM compartment lid at the bottom of the unit and slide RELEASE in the direction of the arrow. Then, release your finger slowly from the lid.

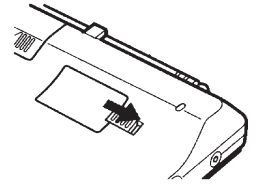

- 2 Remove the ROM compartment lid and the ROM in the compartment. Be careful not to touch the contact surfaces (metallic parts).

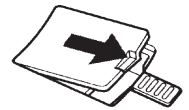

- 3 Insert the projection of the ROM in the compartment cavity and place the replacement ROM in the ROM compartment with the contact surface facing down. Be careful not to touch the contact surfaces.

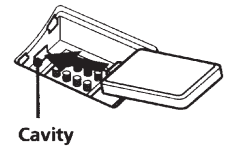

- 4 Insert the projections of the ROM compartment lid in the compartment cavities and lock the cover by sliding RELEASE opposite the direction of the arrow while holding down the lid.

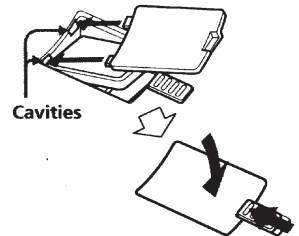

Note

Do not touch the contact surfaces on the ROM or the radio, as this may cause a malfunction.

Cleaning the SW STATION CALL ROM contact surface

If "NO" "ROM" is displayed with the SW STATION CALL ROM inserted in the ROM compartment, the contact surface of the ROM may be dirty.

Remove the ROM following the steps above and clean the contact surface with a cotton swab.

Note

Do not clean the contact springs of the main unit, as they may deform and cause a malfunction.

46^{GB} Additional information

AEP, 7AEP model only

Connecting short land as in the figure when changed main board.

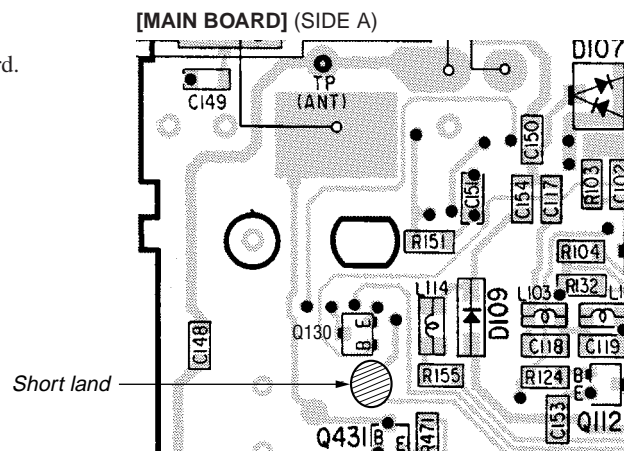

LOCATION AND FUNCTION OF CONTROLS

Preparation

Location of parts and controls

Refer to the pages in the parentheses for details.

Front

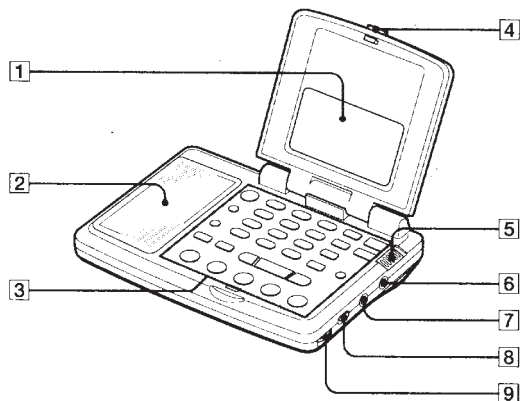

- | | |
|---------------------|--|
| 1 Display (7) | 7 LINE OUT (recording output) jack (35) |
| 2 Speaker | 8 TONE/ST•MONO (stereo•monaural) selector (17) |
| 3 Controls (6) | 9 VOL (volume) control (17) |
| 4 OPEN button (4) | |
| 5 HOLD switch (42) | |
| 6 (headphones) jack | |

Opening the cover

Push the OPEN button to open the cover. Adjust the angle to your choice.

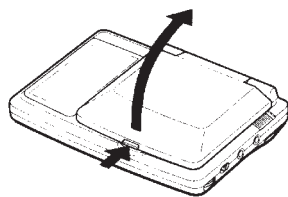

Rear

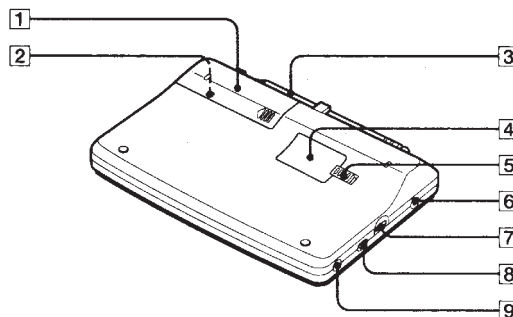

- | | |
|--|--|
| 1 Battery compartment (9) | 5 RELEASE (ROM compartment lid slide open) switch (46) |
| 2 RESET button
Press this button in the battery compartment with a pointed object when the radio fails to function properly. The clock settings, etc., will revert to the factory preset. The frequencies you have preset in the memory are retained. | 6 DC IN 3V (external power input) jack (11) |
| 3 Telescopic antenna (17) | 7 ATT (attenuator) control (21) |
| 4 ROM compartment lid (46) | 8 ATT ON•OFF (attenuator on•off) selector (21) |
| | 9 AM EXT ANT (external antenna) jack (33) |

Extending the antenna

Gently pull out the base of the antenna before rotating it, as shown below.

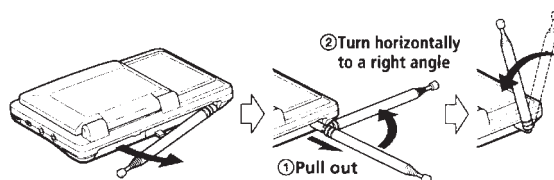

Preparation

Controls

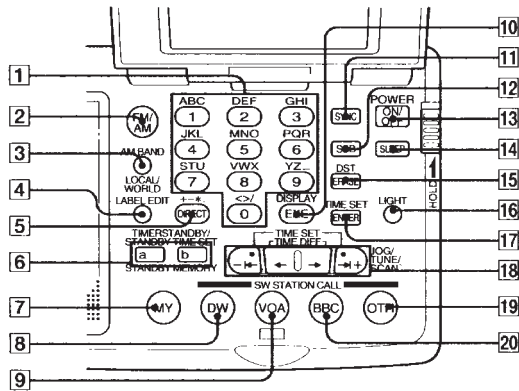

- | | |
|---|--|
| <p>1 Number buttons (16, 22, 36)</p> <p>2 FM / AM button (16, 43)</p> <p>3 AM BAND • LOCAL / WORLD (local time / world time) button (14, 18)</p> <p>4 LABEL EDIT button (36)</p> <p>5 DIRECT button (16)</p> <p>6 STANDBY MEMORY • TIMER STANDBY / STANDBY TIMESET button (38)</p> <p>7 MY button (27)</p> <p>8 DW button (24)</p> <p>9 VOA button (24)</p> <p>10 EXE • DISPLAY button (13, 16, 36)
Press to switch to clock display while operating the radio. Press again to return to the previous display. If you do not press the button, the display will return to the previous condition in about 10 seconds.</p> | <p>11 SYNC (Synchronous detection) button (31)</p> <p>12 SSB (Single Side Band) button (30)</p> <p>13 POWER ON / OFF button (16)</p> <p>14 SLEEP button (41)</p> <p>15 ERASE • DST (Daylight Saving Time) button (12, 23, 29, 40)</p> <p>16 LIGHT button
Press this button to illuminate the display for approximately 30 seconds.</p> <p>17 ENTER • TIME SET button (12, 22, 27, 38)</p> <p>18 JOG / TUNE / SCAN • TIME DIFF / TIME SET buttons (12, 18, 20)</p> <p>19 OTH (others) button (25)</p> <p>20 BBC button (24)</p> |
|---|--|

Display

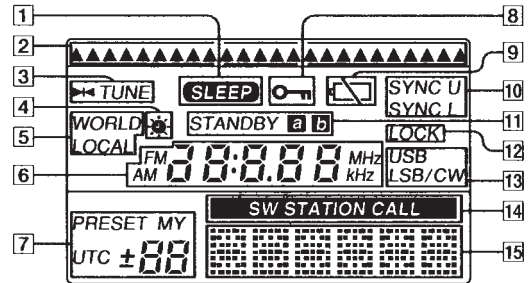

- | | |
|--|--|
| <p>1 SLEEP indicator (41)
Appears when the sleep timer is in effect.</p> <p>2 Time zone indicator (12, 14)
Points at the time zone on the map corresponding to your time difference setting.</p> <p>3 TUNE indicator (16)
Appears when a station is tuned in.</p> <p>4 ☀ (Daylight Saving Time) indicator (12, 14)
Appears when the time display is adjusted to the Daylight Saving Time.</p> <p>5 WORLD • LOCAL indicator (12, 14)</p> <p>6 Time / frequency display (12, 16)</p> <p>7 Memory number / time difference display (12, 22, 27)</p> <p>8 HOLD indicator (42)
Appears when HOLD is in effect. All buttons will be inoperative.</p> | <p>9 Battery indicator (10)</p> <p>10 SYNC U • SYNC L (synchronous detection) indicators (31)</p> <p>11 STANDBY a • b indicators (38)
Appear when standing by for timer activated reception.</p> <p>12 LOCK (synchronous detection lock) indicator (31)
Appears when synchronous detection is in effect.</p> <p>13 USB • LSB / CW (single side band / continuous wave) indicators (30)</p> <p>14 SW STATION CALL indicator (24)</p> <p>15 Label display (12, 16)
Names of the preset stations, cities, bands or meter bands are displayed.</p> |
|--|--|

Short wave active antenna AN-LP2

Refer to page 32 on how to use the active antenna.

Antenna controller

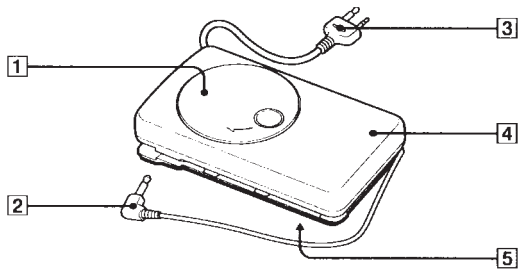

- 1 Cord winder
- 2 Short cord
- 3 Long cord
- 4 Power lamp
- 5 Battery compartment

Antenna module

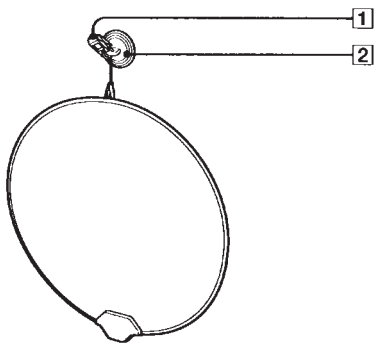

- 1 Clip
- 2 Suction cup

Power sources

Operating on batteries

To operate the unit on house current, see "Operating on house current", page 11.

To operate the unit on a car battery, see "Operating on car battery", page 11.

- 1 Slide and open the battery compartment lid.

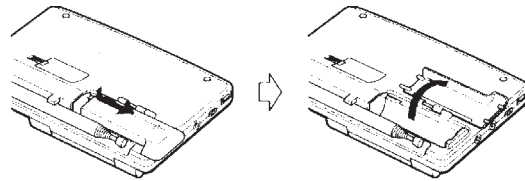

- 2 Insert two R6 (size AA) batteries in the battery compartment.
Insert with correct polarity as shown.

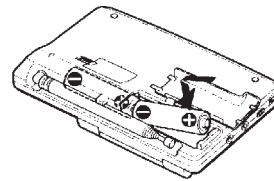

- 3 Close the battery compartment lid.

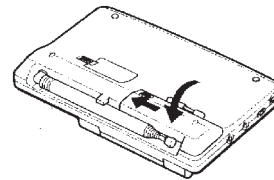

Preparation

Replacing the batteries

The sound will be distorted and "⏻" will flash in the display when the batteries become weak. Replace both batteries with new ones.

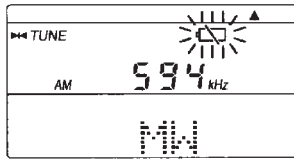

Battery Life

	Sony LR6 alkaline (size AA)	Sony R6(size AA)
FM	approx. 32 hours	approx. 10 hours
AM	approx. 23 hours	approx. 8 hours

Tips

- Replace the batteries within 3 minutes. Otherwise, the clock setting will be erased. Frequencies preset in the memory are not erased.
- When the batteries are completely exhausted, the power turns off, and "⏻" stops flashing and lights up in the display. All buttons except the LIGHT button will become inoperable. The buttons will not become operable again until you replace the batteries and press POWER ON/OFF to turn on the power and clear the "⏻" indication.

Notes on dry batteries

- Insert the batteries with the correct polarity.
- Do not mix new and used batteries. Do not mix different types of batteries.
- Do not try to charge dry batteries, as they cannot be charged.
- Remove the batteries when the unit is not to be used for a long time.
- Should any battery leakage occur, wipe the battery compartment thoroughly before installing new batteries.

Operating on house current

To operate the unit on house current, connect the supplied AC power adaptor* to the DC IN 3V jack of the unit.

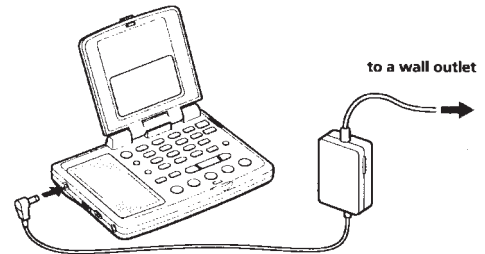

Notes on the AC power adaptor

- Do not bend or twist the power cord forcibly. Do not place heavy objects on the power cord.
- When disconnecting the AC power adaptor from the wall outlet, pull out by the plug. Do not pull the cord itself.
- Disconnect the AC power adaptor from the wall outlet and the radio when the unit is not to be used for a long period of time.

Tip

When the AC power adaptor or the car battery cord is plugged into the DC IN 3V jack, the batteries are disconnected, and the unit automatically switches to external power source.

Operating on car battery

To operate the unit on car batteries, connect a recommended Sony car battery cord to the DC IN 3V jack of the unit. Refer to its Operating Instructions for details.

Notes on external power sources

- Keep the batteries installed even when operating on external power, as they supply power for the unit's memory backup. Replace the batteries once a year.
- Turn off the unit when connecting or disconnecting external power sources. Otherwise, the power may go off and "⏻" may appear. In this case, turn on the power again to clear the "⏻" indication.
- When operating the unit on batteries, first disconnect the AC power adaptor or the car battery cord from the wall outlet or car battery, then disconnect the AC power adaptor or the car battery cord from the DC IN 3V jack of the unit. The unit will not run on batteries as long as the DC IN 3V jack is plugged in.
- Use only the recommended AC power adaptor or car battery cord manufactured by Sony. Using AC power adaptors or car battery cords with different specifications (polarity of the plug, etc.) will result in malfunction and damage to the unit.
- Use the supplied AC plug adaptor* if the AC power adaptor plug does not match your wall outlet.



* Not supplied for models for certain countries. See "Specifications".

Setting the clock

Setting the Local Time

Set the clock if "0:00" flashes in the display (i.e., when you installed the batteries for the first time or after you reset the clock). Set the clock with the radio turned off.

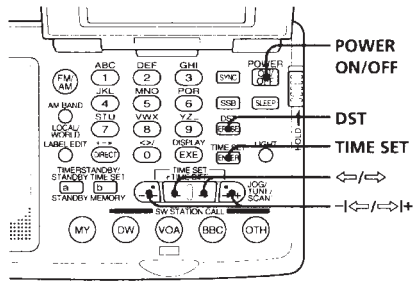

LOCAL time signifies the time for your time zone, while WORLD time is the time for any other time zone in the world.

Clock adjustment is done in LOCAL time. Before setting the clock, refer to the table on page 15 and check the time difference between your area and the UTC (Coordinated Universal Time). Names of major cities and their time differences from the UTC are preset in the unit's memory.

- 1 If the radio is turned on, press POWER ON/OFF to turn it off.
- 2 Hold down TIME SET and press ← or → to choose a city or the time difference between your local time and the UTC.
When TIME SET is pressed, the clock display will automatically switch to LOCAL time if WORLD time had been displayed. The LOCAL indication flashes. Each time you press ← or →, the time zone indicator will move to the right or left.
When you release TIME SET, LOCAL indication will stop flashing and light up. Your local time zone has been selected.
- 3 Press DST if your area is now under daylight saving time.
☀ appears in the display.
If daylight saving time is not used in your area, or if ☀ is already displayed, skip this step.



- 4 Hold down TIME SET and press ← or → to set the local time.
Each time you press ← or →, the current time will decrease or increase by a minute.
To change the digits rapidly, hold down ← or →.

- 5 Release TIME SET.
" : " starts flashing and the clock starts running.

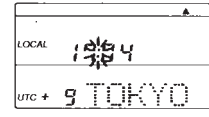

To switch to clock display while the radio is turned on
Press EXE. The current time appears for about 10 seconds and then returns to the previous display. Press EXE again to return to the previous display manually.

The display will not switch to the clock while the radio is running a scan.

For areas adopting daylight saving time (summer time)
Press DST to light up the ☀ indication if you are now in the summer time period (step 3 in the previous page). If you are now in the standard time period, press DST at the beginning of the daylight saving time period. Press again at the end of the daylight saving time period to clear the indication. The time display will be adjusted accordingly.

Note
You cannot set the clock while listening to the radio.
If the radio is on, press POWER ON/OFF first to turn off the radio.

- Tips**
- The clock is displayed in the 24 hour system.
 - Press TIME SET to stop the flashing of "0:00".
 - To adjust the time to the second, release TIME SET at the time of the tone.

Preparation

Setting the clock (continued)

Finding out the time in other areas of the world

Besides your local time, you can display the time for any other area in the world (WORLD time). Turn off the radio to display the WORLD time.

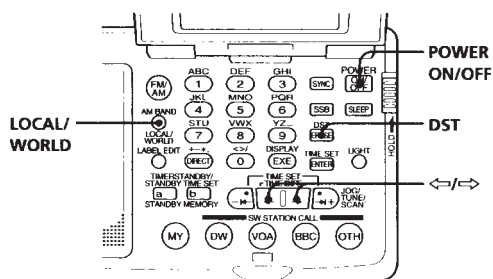

- 1 If the radio is turned on, press POWER ON/OFF to turn it off.
- 2 If the LOCAL indication is displayed, press LOCAL/WORLD to switch the indication to WORLD.
- 3 Press \leftrightarrow or \Rightarrow to choose a city or the time difference with the UTC.
- 4 Press DST to light up the \star indication if the specified area is now under daylight saving time.

If daylight saving time is not used in the desired area, or if \star is already displayed, skip this step.
The current time for the area you have specified will appear in the display.

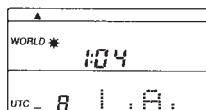

To switch back to the LOCAL time display

Press LOCAL/WORLD again.

If the desired city name or area name is not preset

Select the area by selecting the time difference with the UTC.

To edit the label (i.e., name of the city) for the time zone, see "Editing labels", page 36.

Time difference between local time and UTC

The table shows the time difference of each time zone with the UTC, which could be formulated as follows:

$$\text{Time difference} = \text{Local time}^* - \text{UTC}$$

The number of hours marked with a plus sign (+) indicate the hours ahead of the UTC, while those marked with a minus sign (-) indicate the hours behind the UTC.

Time difference	Label **	City or area	Other cities in the area	Scan step
± 0	LONDON	London		9 kHz
+ 1	C.EURO	Central Europe	Amsterdam, Berlin, Brussels, Lisbon, Madrid, Paris, Rome, Stockholm, Vienna, Zurich	
+ 2	CAIRO	Cairo	Athens, Istanbul	
+ 3	JEDDAH	Jeddah	Nairobi, Riyadh, Moscow	
+ 4	DUBAI	Dubai		
+ 5	KARACH	Karachi		
+ 6	DHAKA	Dhaka(Dacca)		
+ 7	BNGKOK	Bangkok	Jakarta	
+ 8	S.PORE	Singapore	Beijing, Hongkong	
+ 9	TOKYO	Tokyo	Seoul	
+ 10	SYDNEY	Sydney	Guam	
+ 11	SOLMON	Solomon	Noumea	
+ 12	AUKLND	Auckland	Fiji	10 kHz
- 11	SAMOA	Samoa		
- 10	HAWAII	Hawaii	Honolulu, Tahiti	
- 9	ANCHRG	Anchorage		
- 8	L.A.	Los Angeles	San Francisco, Vancouver	
- 7	DENVER	Denver	Calgary	
- 6	CHICAG	Chicago	Dallas, Mexico City	
- 5	N.Y.	New York	Lima, Panama, Toronto	
- 4	CARACS	Caracas	Santiago	
- 3	RIO	Rio de Janeiro	Buenos Aires, San Paulo	
- 2	FN.ISL	Fernando island		9 kHz
- 1	AZORES	Azores Island		

* Local time prior to DST (daylight saving time) adjustment. The DST setting does not affect the time difference indication.

** Default labels. To change the labels, see "Editing labels", page 36.

Automatic adjustment of the MW channel step

A channel step is the basic interval unit in a frequency allocation system. The MW channel step differs from country to country (10 kHz for North and South American countries, and 9 kHz for Japan, Europe and other countries). Normally, the scanning or tuning steps needs to be adjusted to match the system for the area to scan or manually tune MW frequencies. This unit, however, determines your local area from your time zone setting (the time difference from the UTC) and automatically chooses the appropriate channel step.

Various ways of reception

Direct tuning

If you know the frequency of the station you want to listen to, enter the frequency digits with the number buttons directly.

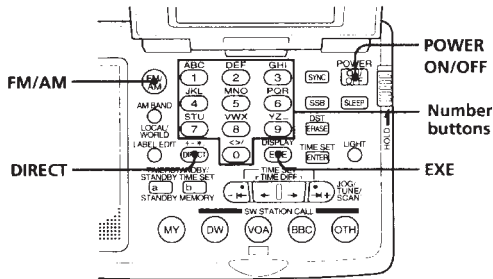

- 1 Press POWER ON/OFF to turn on the radio.
- 2 Press FM/AM to select either band.
To listen to SW (short wave), MW (medium wave) or LW (long wave) broadcasts, select AM.
- 3 Press DIRECT.
The frequency disappears and "DIRECT" appears in the display.
- 4 Press the number buttons and input the frequency of the desired station.
FM band: You can ignore the decimal point.
To enter 84.7 MHz, for example, press 8, 4 and 7.
AM band: You can ignore the last 3 digits if they are all zero.
To enter 10,000 kHz, for example, press 1 and 0.
Complete each button operation within 10 seconds.
The minimum frequency step for direct input is 0.05 MHz (50 kHz) for FM, and 1 kHz for AM.
- 5 Press EXE to enter.
"▶▶ TUNE" appears in the display when the station is tuned in.

To correct input

Press DIRECT and repeat from step 3.

If "TRY" "AGAIN" appears in the display

When you enter an invalid frequency (i.e., a figure that is not within the frequency range of the band you chose), you will hear a beep and "TRY" "AGAIN" appears in the display. Check the frequency and repeat from step 3.

Notes

- Complete each operation from step 3 to 5 within 10 seconds. If the display returns to the previously tuned frequency, repeat from step 3.
- The unit will not beep if the beep is set to BEEP OFF (see "Turning off the beep", page 43).

Other operations

To	Press or adjust
Fine tune the reception	-I<=>, <=>, =>, =>I+
Adjust the volume	VOL
Turn off the radio*	POWER ON/OFF

*The radio tunes to the previously tuned frequency when you turn on the radio.

To improve reception

FM reception

Gently pull out the telescopic antenna and adjust the length, angle and direction (see "Extending the antenna", page 5).

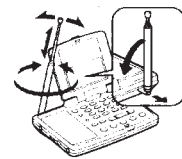

MW/LW reception

Retract the telescopic antenna and rotate the unit to reorient the built-in ferrite bar antenna.

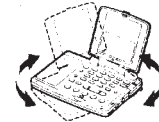

SW reception

Gently pull out the telescopic antenna vertically to its full length.

For SW reception, you can enjoy even better reception by using the supplied external antenna (see "Using the supplied external antenna", page 32).

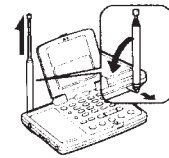

Tips

- Plug in the supplied stereo headphones to enjoy FM stereo reception. Set ST • MONO to ST or MONO to select stereo or monaural reception. Select MONO when reception is noisy or unclear.
- When listening to news programs, etc., set TONE to NEWS. Speaking voices will be heard clearer. When listening to music programs, set TONE to MUSIC.
- Reception of frequencies around 3.0MHz and 3.64 MHz may be difficult due to internal spurious signals generated by the built-in oscillators.

Various ways of reception (continued)

Manual tuning

Use \leftarrow , \rightarrow or \leftarrow , \rightarrow to change the frequency manually step by step. The outer buttons (\leftarrow and \rightarrow) change the frequency in large frequency steps, and the inner buttons (\leftarrow and \rightarrow) in small frequency steps.

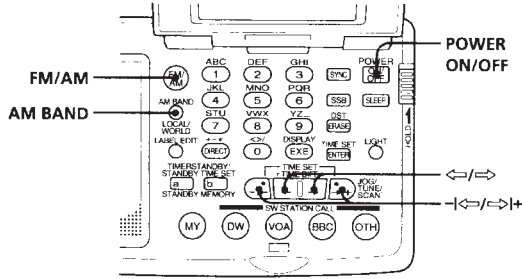

- 1 Press POWER ON/OFF to turn on the radio.
- 2 Press FM/AM to select either band.
To listen to SW, MW or LW broadcasts, select AM.
- 3 For the AM bands, hold down AM BAND and press \leftarrow or \rightarrow to select MW (medium wave), LW (long wave) or a meter band (short wave).

The name of the band or the meter band and its lowest frequency appears in the display.
For FM, skip this step.



- 4 Press \leftarrow , \rightarrow or \leftarrow , \rightarrow repeatedly to tune in to the desired broadcast station.
With each press, the frequency changes in the channel steps shown below. (The figures in the parentheses indicate the steps in the SSB mode).

Band	\leftarrow or \rightarrow	\leftarrow or \rightarrow
FM	0.05 MHz	0.05 MHz
SW	5 kHz (1 kHz)	1 kHz (0.1 kHz**)
MW	9 or 10 kHz* (1 kHz)	1 kHz (0.1 kHz**)
LW	9 kHz (1 kHz)	1 kHz (0.1 kHz**)

* The frequency step is adjusted automatically to your time zone according to your local time zone setting (see "Automatic adjustment of the MW channel step", page 15).

** Units of 0.1 kHz are not indicated in the display.

Tips

- The unit starts scan tuning when \leftarrow or \rightarrow is held down (see "Scan tuning", page 20).
- The frequency changes rapidly when \leftarrow or \rightarrow is held down, and stops when released. In the AM bands (MW, SW, and LW), the unit scans continuously in the range of 150 to 29,999 kHz.

Frequency range of the bands/meter bands

The short wave range is divided into 14 bands that are generally referred to as "meter bands".

(kHz for AM / MHz for FM)

Band	Frequency Range	Scan Frequency Range	Meter band	
AM	LW	150-529	153-522	—
		MW	530-1620	530-1620* 531-1620**
	SW		1621-29999	2250-2550
		3150-3450		90 meter band
		3850-4050		75 meter band
		4700-5100		60 meter band
		5900-6250		49 meter band
		7100-7400		41 meter band
		9400-10000		31 meter band
		11500-12150		25 meter band
		13500-13900		22 meter band
		15000-15700		19 meter band
		17450-18000		16 meter band
		18850-19100		15 meter band
21450-21950	13 meter band			
25600-26100	11 meter band			
FM	76.00-108.00	76.00-108.00	—	

*1 10 kHz channel step (see page 15).

*2 9 kHz channel step (see page 15).

Note

The actual frequency range of short wave broadcasts and the range of the meter bands for this unit may differ. Refer to the supplied "Wave Handbook" for more information.

Various ways of reception (continued)

Scan tuning

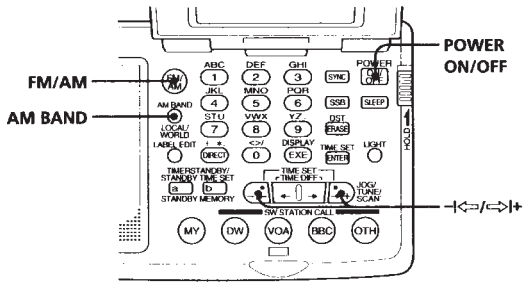

- 1** Press POWER ON/OFF to turn on the radio.
- 2** Press FM/AM to select either band.
To listen to SW, MW or LW broadcasts, select AM.
- 3** For AM bands, hold down AM BAND and press -I< or =>I+ to select MW (medium wave), LW (long wave) or a meter band (short wave).
The name of the band or the meter band and its lowest frequency appear in the display.
For FM, skip this step.
- 4** Hold down -I< or =>I+. Release when the unit starts scanning.
"SCAN" is displayed. The unit stops at each reception and resumes scanning after about 3 seconds.
The unit scans within the frequency range of the chosen band or meter band (see "Frequency range of the bands/meter bands", page 19). In the SSB reception mode, the unit scans the whole 150 to 29999 kHz frequency range.
- 5** Press -I< or =>I+ to stop scanning and listen to the desired broadcast.
"SCAN" disappears and the name of the band appears in the display.

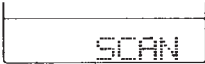

Tips

- The unit scans the frequencies in descending order when holding down -I<, and in ascending order when holding down =>I+.
- To change scanning direction, hold down either -I< or =>I+ opposite to the current direction. This is convenient when, for example, you want to return to the previous reception after the unit has resumed scanning.
- When scanning for MW broadcasts at night when reception is intense, or when scanning under prevalent interference, the unit may stop scanning to null broadcasts frequently. Switch ATT to ON and adjust sensitivity with the ATT Control (see "Controlling scan stops", below). Under normal conditions, set ATT to OFF.

Controlling scan stops — using the ATT switch and the ATT Control

Use the ATT (attenuator) switch and the ATT Control to control reception sensitivity when the unit stops scanning to null broadcasts frequently or when scanning under prevalent interference. Under normal conditions, use the radio with ATT set to OFF (i.e., with maximum sensitivity).

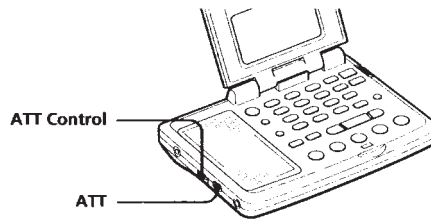

The ATT Control is activated when ATT is switched ON. Turn the ATT Control toward MAX to reduce sensitivity. The radio will skip weaker signals and stop at only stronger ones.

Note

If the ATT Control is turned too much toward MAX, the radio will not stop on any weaker signals at all. Switch ATT to OFF if you do not need to use the attenuator.

Listening to the radio

Various ways of reception (continued)

Preset tuning

You can preset a total of 20 stations of your choice to the number buttons (10 for FM and 10 for AM).

Presetting stations

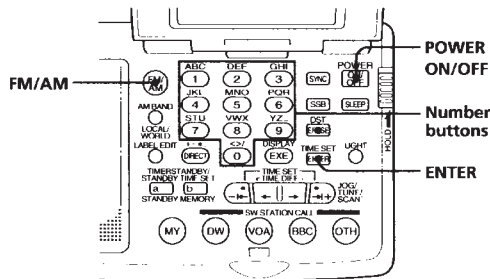

- 1 Press POWER ON/OFF to turn on the radio.
- 2 Tune in to the station you want to preset.
- 3 Hold down ENTER and press a number button (0–9) of your choice.

When ENTER is held down, "PRESET MY" will flash in the display.

A beep sounds when a number button is pressed. The station is stored to the selected button. The preset number and the preset label are displayed.

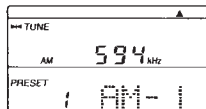

Note

If a station is already stored to the button you chose, it will be overwritten by the new preset. If the preset label had been edited, it will return to the default setting.

Default preset labels

Each time a station is preset, the preset key is assigned the default preset label as shown.

To change labels, see "Editing labels", page 36.

Button	AM	FM
1	AM-1	FM-1
2	AM-2	FM-2
3	AM-3	FM-3
4	AM-4	FM-4
5	AM-5	FM-5
6	AM-6	FM-6
7	AM-7	FM-7
8	AM-8	FM-8
9	AM-9	FM-9
0	AM-0	FM-0

Tuning in to a preset station

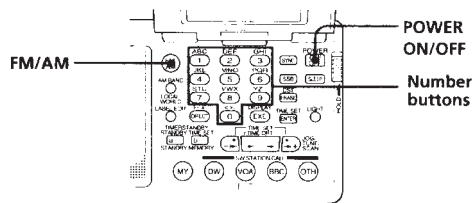

- 1 Press POWER ON/OFF to turn on the radio.
- 2 Press FM/AM to select either band.
- 3 Press a number button (0–9) of your choice.
The radio receives the station assigned to the button.

If no station is preset

A beep sounds and "MEMORY" "EMPTY" appears in the display. Then the display will return to the previous condition.

Notes

- The radio may have frequencies stored in the preset memory at factory shipment.
- The unit will not beep if the beep is set to BEEP OFF (see "Turning off the beep", page 43).

Erasing a preset station

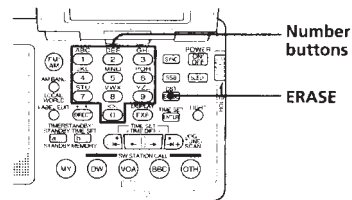

- 1 Press a number button (0–9) for the preset station you want to erase.
- 2 Hold down ERASE.
The preset number flashes in the display while ERASE is held down.
A beep sounds after 3 seconds and the station assigned to the button you chose is erased. The preset number and the preset label disappear.

Note

When a preset station is erased, any changes to its default label is erased as well.

Various ways of reception (continued)

SW STATION CALL tuning

Tune in to major short wave stations by just pressing the station buttons: DW, VOA, BBC and OTH (others). The radio automatically chooses the frequencies used in your time zone from the SW STATION CALL ROM* encased at the bottom of the unit, scans for them, and stops scan at reception.

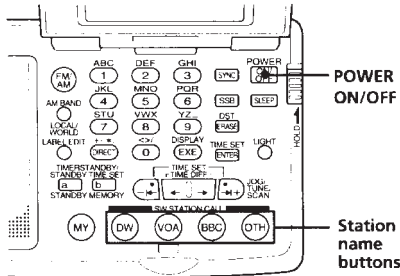

*ROM = Read Only Memory

1 Set the time zone to your area.

For LOCAL time, see "Setting the Local Time", page 12.
For WORLD time, see "Finding out the time in other areas of the world", page 14.

SW STATION CALL automatically selects **only the frequencies that are receivable in the area corresponding to your time zone setting**, regardless of LOCAL or WORLD time. Thus, it is crucial that you set the time zone properly to match your current location before using SW STATION CALL.

2 Press POWER ON/OFF to turn on the radio.

3 Press the station button of your choice.

"SW STATION CALL", the station name and a frequency is displayed. The time difference from the UTC and the time zone indicator flash for about 3 seconds, and then light up. Confirm your time zone setting. The frequency actually displayed may be different from the illustration.

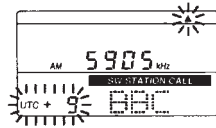

4 Press the same station button again.

The radio scans the frequencies for your area in ascending order, and stops at reception.
Press the button again to resume scanning.

To stop scanning

Press the same station button during scan.

To manually recall the selected frequencies one by one

Hold down the station button and press \leftarrow , \rightarrow or $-I\leftarrow$, $\rightarrow I+$.

The frequency changes quickly when $-I\leftarrow$ or $\rightarrow I+$ is held down, and stops when released.

Tip

When scanning at night when reception is intense, or when scanning under prevalent interference, the unit may stop scanning to null broadcasts frequently. Switch ATT to ON and adjust sensitivity with the ATT Control (see "Controlling scan stops", page 21). Under normal conditions, set ATT to OFF.

Stations recalled by the SW STATION CALL station buttons

Button	Station and program
DW	English and German programs of Deutsche Welle
VOA	English programs of Voice of America
BBC	English programs of British Broadcasting Corporation
OTH	Choose one of the following*; R.NED – English and Dutch programs of Radio Nederland RFI – English and French programs of Radio France International R.JPN – English and Japanese programs of Radio Japan REF – English and Spanish programs of Radio Exterior de España CRI – English and Chinese programs of China Radio International

*Selecting the station for the OTH button

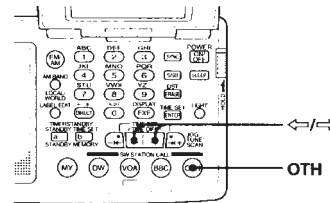

Turn off the radio if it is turned on.

Hold down OTH and press \leftarrow or \rightarrow . Release OTH when the station of your choice appears in the display.

Steps for reception is the same as the other SW STATION CALL buttons.

When there is no reception

If the radio was not able to receive any of the frequencies for the time zone stored in the ROM, scanning stops with a beep when the radio returns to the frequency where it started scanning.

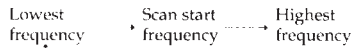

Short wave reception may be difficult at times due to various factors, such as sunspot activity and atmospheric conditions. Furthermore, the major broadcast stations whose data are stored in the ROM may change the broadcast time and/or frequencies at the change of season, etc. In such cases, the radio may not be able to receive the frequencies stored in the SW STATION CALL ROM.

Updating the SW STATION CALL ROM

To conform with possible changes in frequencies, the SW STATION CALL ROM is designed to be replaceable by the user to an updated version of the ROM. The newest SW STATION CALL ROM is sold by F Corporation. The ROM is to be updated in around October every year. We recommend the ROM to be replaced at least once in 2 to 3 years.

To purchase the newest ROM, refer to "Purchasing the latest SW STATION CALL ROM" and contact F Corporation.

To exchange the ROM, see "Exchanging the SW STATION CALL ROM", page 46.

Notes

- Many of the worldwide broadcast programs of the major broadcast stations stored in the ROM are broadcast only at certain times of the day. If the station is not broadcasting on the scanned frequency at the time, the radio will not receive any broadcast or receive broadcast by some other station, such as a local station, broadcasting on the same frequency.
- If the frequency is changed by manual tuning, etc., when "SW STATION CALL" indication is lit in the display, the radio will exit SW STATION CALL and the indication will disappear.
- If there is no frequency for the station corresponding to the time zone stored in the ROM, a beep sounds, "MEMORY" "EMPTY" appears in the display, and the radio returns to the previous condition.
- If you press a station button without the ROM in the ROM compartment of the radio, a beep sounds, "NO" "ROM" appears in the display, and the radio returns to the previous condition. If the ROM is displaced when "SW STATION CALL" indication is lit in the display, a beep sounds, "NO" "ROM" appears in the display, and the radio changes to manual tuning.
- If "NO" "ROM" is displayed with the SW STATION CALL ROM inserted in the ROM compartment, the contact surface of the ROM may be dirty. See "Cleaning the SW STATION CALL ROM contact surface", page 46, and clean the contact surface with a cotton swab. Do not clean the contact springs of the main unit, as they may deform and cause a malfunction.

Various ways of reception (continued)

MY-Memory tuning

Preset up to 100 frequencies of any band (FM, SW, MW or LW) to the MY button. You can scan these stations or tune in one by one.

Presetting stations to MY-Memory

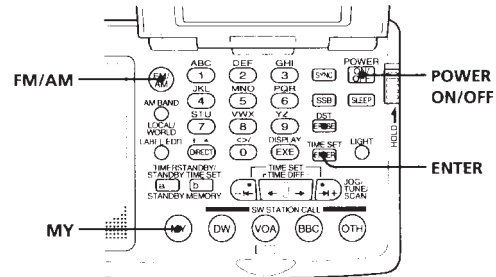

Listening to the radio

- 1 Press POWER ON/OFF to turn on the radio.
- 2 Tune in to the station you want to preset.
- 3 Hold down ENTER and press MY.
When ENTER is held down, "PRESET MY" will flash in the display.
A beep sounds when MY is pressed.
The station is stored to the lowest available MY-Memory number (00 to 99). The MY-Memory number and the MY-Memory label are displayed.

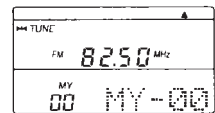

Default MY-Memory labels

Each time a station is stored to MY-Memory, it is assigned the default MY-Memory label "MY-xx" (with the memory number in place of "xx").

To change labels, see "Editing labels", page 36.

Note

The radio may have frequencies stored in MY-Memory at factory shipment. In this case, erase them before presetting stations to MY-Memory (see "Erasing a MY-Memory preset", page 29).

Tips

- If you press MY with all the MY-Memory numbers (00 to 99) assigned a station, a beep sounds, "MEMORY" "FULL" appears in the display, and the radio returns to the previous condition.
- MY-Memory tuning is not affected by the time zone setting.

Tuning in to a MY-Memory station

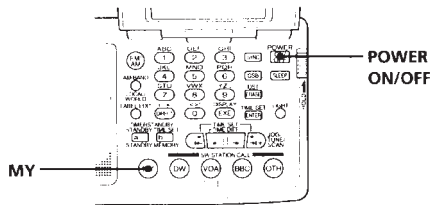

- 1 Press POWER ON/OFF to turn on the radio.
- 2 Press MY.
The radio enters the MY-Memory tuning mode.
- 3 Press MY again.
The radio scans the frequencies stored in MY-Memory and stops at reception.
Press the button again to resume scanning.

To stop scanning

Press MY during scan.

To manually recall the MY-Memory frequencies one by one

Hold down MY and press \leftarrow , \rightarrow or $-I\leftarrow$, $\rightarrow I+$.

The frequency changes quickly when $-I\leftarrow$ or $\rightarrow I+$ is held down and stops when released.

Tips

- MY-Memory scans only the stored memory numbers and skips the empty ones.
- MY-Memory scans fastest if the frequencies are stored in ascending or descending order.
- If MY is pressed with no frequency stored in MY-Memory, a beep sounds and "MEMORY" "EMPTY" appears in the display. Then the display returns to the previous condition.
- When scanning at night when reception is intense, or when scanning under prevalent interference, the unit may stop scanning to null broadcasts frequently. Switch ATT to ON and adjust sensitivity with the ATT Control (see "Controlling scan stops", page 21). Under normal conditions, set ATT to OFF.

When there is no reception

If any of the frequencies stored in MY-Memory was not received, scanning stops with a beep when the radio returns to the frequency where it started scanning.

Lowest stored MY-Memory number Scan start MY-Memory number Highest stored MY-Memory number

Erasing a MY-Memory preset

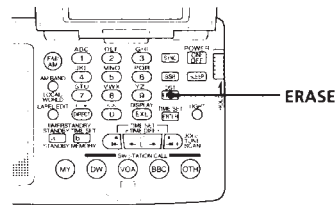

- 1 Recall the MY-Memory number you want to erase.
- 2 Hold down ERASE.
The MY-Memory number flashes in the display while ERASE is held down.
A beep sounds after 3 seconds and the station assigned to the MY-Memory number is erased. The MY-Memory number and the MY-Memory label disappear.

Note

When a MY-Memory station is erased, any changes to its default label is erased as well.

To change the station stored in MY-Memory

You cannot overwrite a frequency stored in MY-Memory with a new one. Erase the particular MY-Memory number first, then store a new frequency.

Note

MY-Memory stores stations to the lowest available MY-Memory number. Note, thus, that if a MY-Memory number lower than the one you erased is available, the new frequency will be stored to that number.

Receiving SSB and CW Transmissions

You can receive SSB (Single Side Band) and CW (Continuous Wave) transmissions with the built-in BFO circuit.

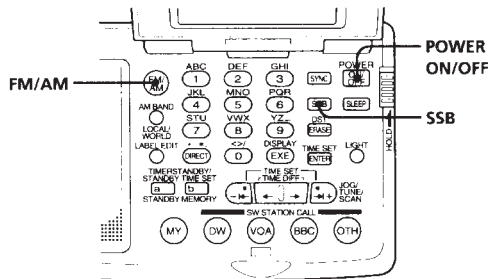

1 Press POWER ON/OFF to turn on the radio.

2 Press FM/AM and select AM.

3 Press SSB to select USB or LSB/CW.

Each time SSB is pressed, the display changes as follows:

(Normal mode) → USB → LSB/CW

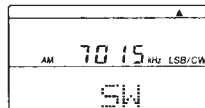

4 Tune in to the desired station.

For tuning methods, see "Various ways of reception", pages 16 to 29.

Tip

For more on SSB and CW, refer to "Tips on radio waves", page 50.

Notes

- The USB or the LSB/CW mode cannot be preset to memory. You can tune in to stations in 0.1 kHz steps in the USB or the LSB/CW mode, but the frequency digit below the decimal point is ignored when memorized.
- If a preset AM frequency is recalled during the USB or the LSB/CW mode, the mode setting remains active and the frequency is received in the respective mode.

Adjusting for optimum AM reception —Synchronous detection

Adjust AM reception (especially SW reception) to optimum condition with synchronous detection.

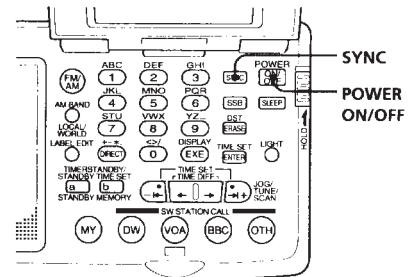

1 Press POWER ON/OFF to turn on the radio.

2 Tune in to the desired station.

For tuning methods, see "Various ways of reception", pages 16 to 29.

3 Press SYNC repeatedly to select the synchronous detection mode with better reception (SYNC U or SYNC L).

Each time SYNC is pressed, the display changes as follows:

(Normal mode) → SYNC U → SYNC L

"LOCK" appears in the display when synchronous detection is in effect.

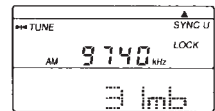

Tip

For more on synchronous detection, see "Tips on radio waves", page 50.

Notes

- Synchronous detection may be cancelled when the batteries become weak.
- Even when you have chosen either of the synchronous detection modes and SYNC U or SYNC L is lit in the display, synchronous detection may not take effect if reception is weak. In this case, "LOCK" will not light up.
- Synchronous detection setting cannot be preset to memory.
- If a preset AM frequency is recalled when either synchronous detection mode is in effect, the mode setting remains active and the frequency is received in the respective mode.

Using the supplied external antenna

Use the supplied Short Wave Active Antenna AN-LP2 for better short wave reception. The antenna gives you stable indoor reception with the built-in amplifier.

This antenna can be used only to receive the short wave meter bands from the 120 meter band to the 11 meter band as seen in "Frequency range of the bands/meter bands", page 19. Be sure to disconnect it for FM, MW or LW reception.

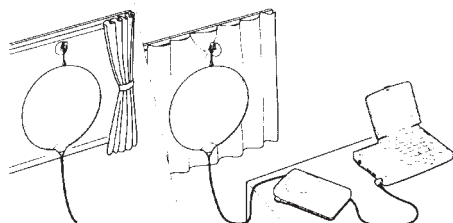

Inserting the Batteries

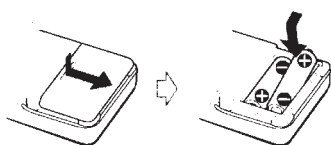

- 1 Open the battery compartment lid of the antenna controller.
- 2 Insert two R6 (size AA) batteries with correct polarity.
- 3 Close the lid.

Battery life of the active antenna

Using Sony R6 (size AA) dry batteries: approx. 40 hours

When to replace the batteries

When the batteries become weak, the POWER lamp of the antenna controller dims. Replace both batteries with new ones.

Setting Up

- 1 Unfold the antenna module slowly.

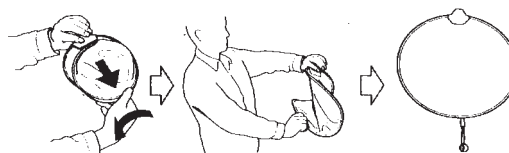

Be careful not to hit anyone or anything when unfolding the antenna module.

- 2 Pull out the long cord with the double pin plug from the antenna controller until it stops, and connect it to the antenna module.
- 3 Attach the antenna module to the window glass or the curtain.
Fix the antenna with the supplied clip or the suction cup, as seen in the illustration on the previous page.
- 4 Connect the short cord with a single pin plug to the AM EXT ANT (AM external antenna) jack of the radio.

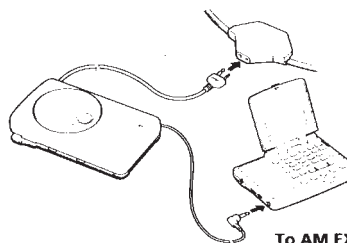

The power supply of the antenna controller is linked to the power supply of the radio. The POWER lamp lights up on the controller. Switch ATT to OFF on the radio.

On setup

- Place the antenna module where reception is well, such as by the window.
- Reception may become poorer if the long cord of the antenna controller is kept near the radio. Keep it as far away from the radio as possible.
- Keep the radio and the antenna away from fluorescent lamps, television sets, telephones, personal computers, etc., as they may generate noise interference.
- Set up the antenna as far away from the street as possible.
- Do not use the antenna outdoors.
- When using the external antenna, be sure to retract the telescopic antenna on the main unit.

After use

- 1 Disconnect the antenna module, antenna controller and radio.
- 2 Reel up the long cord.
- 3 Wrap the short cord to the antenna controller and set it in place.

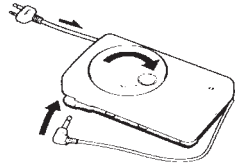

- 4 Twist and fold the antenna module, set it in place, and put it in the carrying case.

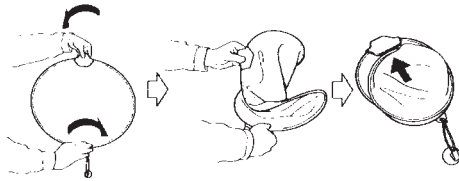

Note

- When receiving FM, MW or LW broadcasts, be sure to disconnect the active antenna. The radio cannot receive these bands with the external antenna plugged in, as the telescopic antenna and the built-in ferrite bar antenna will be disconnected.
- The supplied external antenna is to be used only with this unit. It cannot be used on other radios.
- Do not connect any other antennas other than the recommended active antennas to the AM EXT ANT jack of the unit, as the jack supplies DC voltage to power the recommended active antennas.

Recording broadcasts

Connect the radio to a cassette recorder with connecting cables to record radio broadcasts.

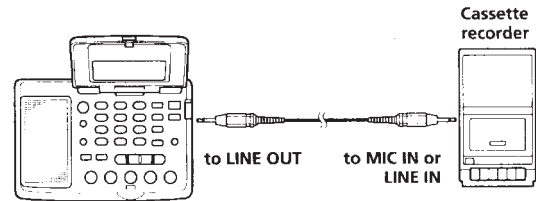

- 1 Connect the radio to a cassette recorder with connecting cords (not supplied). Use the appropriate cord for the type of cassette recorder.

Cassette recorder		Connecting cord
Type	Jack	
Monaural	MIC IN (minijack)	RK-G135
	MIC IN (minijack)	RK-G134
Stereo	LINE IN (minijack)	RK-G136
	LINE IN (pinjack)	RK-G129

- 2 Tune in to the station you want to record.
- 3 Record on the cassette recorder.

If you record with a stereo recorder

FM stereo programs are recorded in stereo. AM programs are recorded monaurally to both channels.

Tip

Adjusting VOL on the radio has no effect on the recording.

Editing labels

You can change the default label for a station preset, time zone, etc., to any combination of up to 6 alphanumeric letters.

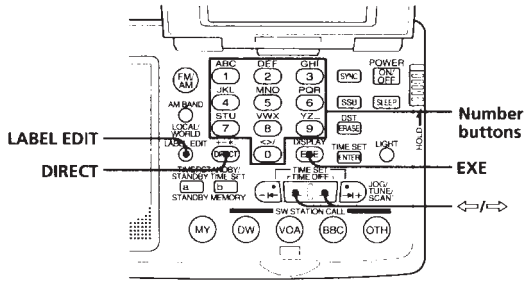

1 Display the label you want to edit by preset tuning (page 22), MY-Memory tuning (page 27), WORLD time display (page 14) or the Standby function (page 38).

2 Press LABEL EDIT.
The first letter of the label flashes.

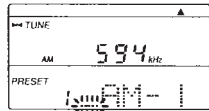

3 Press ← or → to move the cursor to the letter you want to change.

4 Press one of the number buttons (0 to 9) or DIRECT to enter the letter of your choice.
The first letter written above the number button is entered when the button is pressed. Every press of the button changes the letter as follows.

Ex. Pressing number button ①: A → B → C → 1

① A B C 1	② D E F 2	③ G H I 3
④ J K L 4	⑤ M N O 5	⑥ P Q R 6
⑦ S T U 7	⑧ V W X 8	⑨ Y Z . 9
DIRECT + - * .	⑩ < > / 0	—

. indicates a blank space.

5 Repeat steps 3 and 4 to change other letters.
Complete each button operation within 20 seconds.

6 Press EXE.
A beep sounds and the displayed letters are stored as the label.

If the flashing of the character stops

You took more than 20 seconds to complete a button operation. If the display returns to the original label, press LABEL EDIT again and start over.

To cancel editing

Press LABEL EDIT before pressing EXE.

Notes

- The SW STATION CALL labels cannot be edited.
- The unit does not beep if the beep is set to BEEP OFF (see "Turning off the beep", page 43).
- An edited preset label returns to the default setting if a station is overwritten to the preset button (see "Default preset labels", page 22).

Using the timer

Waking up to the radio or buzzer — Standby function

You can wake up to your favorite radio program using the Standby function. You can preset different frequencies and standby times to STANDBY MEMORY a and b.

To wake up to the buzzer, see "To wake up to the buzzer", page 40.

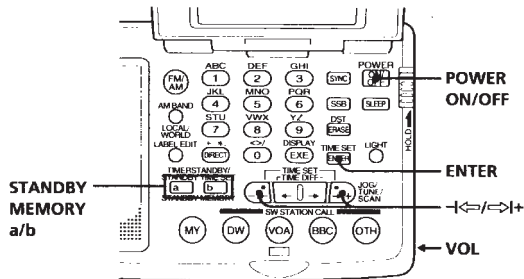

Make sure the clock is set correctly before using the Standby function (page 12).

- 1 Tune in to the station you want to preset.
- 2 Adjust VOL to your choice.
- 3 Hold down ENTER and press STANDBY MEMORY a or b.

When ENTER is held down, "PRESET MY" will flash in the display. A beep sounds when STANDBY MEMORY a or b is pressed. The station is stored to the selected button. The STANDBY MEMORY number (a or b) and the STANDBY MEMORY label are displayed.

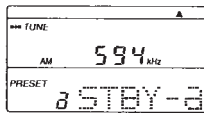

- 4 Press POWER ON/OFF to turn off the radio.
- 5 Hold down the STANDBY MEMORY button you pressed in step 3 and press \leftarrow or \rightarrow repeatedly to set the standby time (i.e., the time the radio is to turn on). "STANDBY" and "a" or "b" flash while the STANDBY MEMORY button is held down.
- 6 Release the STANDBY MEMORY button.

"STANDBY" and "a" or "b" light up and the standby setting is complete. The clock indication returns to the current time. The radio turns on at the standby time to receive the preset broadcast station.

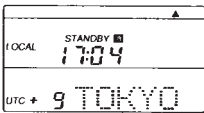

To check the standby time

Hold down STANDBY MEMORY a or b with the radio turned off. The preset standby time is displayed while the button is pressed.

To change the standby time

Repeat steps 4 to 6 and preset a new standby time.

To cancel the standby function

Press STANDBY MEMORY a or b with the radio turned off so that "STANDBY" "a" or "b" is cleared from the display.

Make sure to release the button within a second. If the button is pressed for longer than a second, the radio goes to step 5.

At the standby time

The radio turns on, "SLEEP" lights up, and the preset broadcast station is tuned in. The radio turns off after about 60 minutes.

Notes

- The Standby function is activated when the currently displayed time, whether in LOCAL or WORLD display mode, reaches the standby time. Make sure, therefore, that the time display is in the mode of your choice.
- If a station was already stored to the STANDBY MEMORY button, the previous preset station is overwritten by the new preset. If the preset label had been edited, it will return to the following default:
a = "STBY-a"
b = "STBY-b"
To change labels, see "Editing labels", page 36.
- Make sure that the radio is turned off before setting the standby time. You cannot set the standby time with the radio turned on.

Tips

- To temporarily cancel the Standby function, turn off the radio and slide HOLD in the direction of the arrow so that "O" is displayed. The standby timer goes back to effect when HOLD is turned off ("O" is cleared from the display). See "Using the hold function", page 42.
- Once the standby presets are set, the radio turns on at the preset time everyday unless the standby status is canceled (see "To cancel the standby function", above). Canceling the standby status does not erase the standby setting itself. The setting can be put back to the standby status by pressing STANDBY MEMORY a or b with the radio turned off so that "STANDBY" "a" or "b" is lit in the display.
- If the standby memory is in standby status, it takes effect even when you are listening to the radio. The radio switches to the preset standby frequency at the standby time.
- You can set both STANDBY memories to the standby status at the same time (i.e., both the a and b indicators are lit in the display). The radio turns on at the first standby time to receive the first standby frequency, then switches to the second standby frequency at the second standby time.
- If both STANDBY memories are set to the same standby time, STANDBY a takes precedence.

To wake up to the buzzer

If a STANDBY MEMORY without a frequency preset is activated, the buzzer sounds at the standby time. Erase if a frequency is preset.

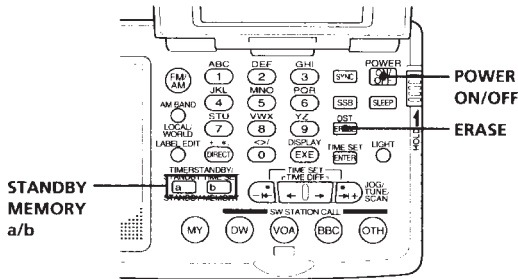

- 1 Press POWER ON/OFF to turn on the radio.
- 2 Press STANDBY MEMORY a or b.
The preset frequency is recalled.
If no frequency is stored, a beep sounds and "MEMORY" "EMPTY" appears in the display. Go to step 4.
- 3 Hold down ERASE.
The Standby Memory number flashes in the display while ERASE is held down.
A beep sounds after 3 seconds and the station assigned to the STANDBY MEMORY button is erased. The Standby Memory number and the Standby Memory label disappear.
- 4 Follow steps 4 to 6 of "Waking up to the radio or buzzer", page 38 to set the standby time (i.e., the time the buzzer is to sound).
The buzzer sounds at the standby time.

To stop the buzzer

Press any button except LIGHT.
The buzzer stops after about 60 minutes if it is left on.

Notes

- The buzzer volume cannot be adjusted with VOL.
- The Standby Memory buzzer sounds regardless of the BEEP OFF setting.
- When a Standby Memory preset is erased, any changes to its default label is erased as well.

Falling asleep listening to the radio — Sleep timer

You can turn off the radio automatically after about 60 minutes using the sleep timer.

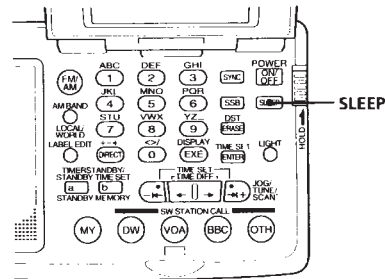

- 1 Press SLEEP.
If the radio was off, the radio turns on.
"SLEEP" lights up.
- 2 Tune in to the station of your choice.
The radio turns off automatically after about 60 minutes.

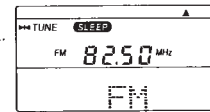

To turn off the radio before the 60 minute duration

Press POWER ON/OFF.

Tips

- If SLEEP is pressed with the radio turned on, "SLEEP" lights up and the radio turns off after about 60 minutes.
- If you press SLEEP to turn on the radio, the radio tunes to the previously tuned frequency.
- If SLEEP is pressed when "SLEEP" is already lit, the sleep countdown is reset and the radio turns off after about 60 minutes from this point.

Warning

To prevent fire or shock hazard, do not expose the unit to rain or moisture.

To avoid electrical shock, do not open the cabinet.

Refer servicing to qualified personnel only.

Features

• World clock feature

Find out the time for any place in the world by selecting a city name.

• Worldwide coverage with FM stereo/SW/MW/LW reception

Simple and precise tuning with the quartz controlled PLL (Phase Locked Loop) synthesizer system.

FM: 76–108 MHz

SW: 1621–29999 kHz

MW: 530–1620 kHz

LW: 150–529 kHz

Refer to the supplied "Wave Handbook" for more information.

• SW STATION CALL tuning

Tune in to major short wave stations just by pressing the station buttons. The radio automatically chooses the frequencies used in your time zone from the ROM data and scans for them.

• MY-Memory tuning

Memorizes and scans up to 100 frequencies of your choice.

• Four other tuning methods to suit your needs

– **Direct tuning:** tune in by inputting the frequency digits directly.

– **Manual tuning:** tune in by manually changing the frequency step by step.

– **Scan tuning:** scans automatically through the band and stops at reception.

– **Preset tuning:** tune in by recalling a preset broadcast station with the single press of a button.

• Label editing

Label preset frequencies, time zones, etc., with a station name, city name, etc., or any combination of up to 6 alphanumeric letters.

• Built-in timer operation

Turns on the radio automatically at any preset time to a station of your choice. Preset two individual standby-times and frequencies under STANDBY MEMORY a and b.

• Sleep timer

Set the sleep timer and fall asleep to the radio. The timer turns off the radio automatically after approximately 60 minutes.

• Stereo FM reception

Use the supplied stereo headphones to enjoy stereo FM.

Tips on radio waves

What is SSB (Single Side Band)?

SSB is very popular among ham and business radio transmissions, and is commonly used in many amateur bands because of its superiority in signal intelligibility. Its impressive signal intelligibility is achieved with minimum interferences when compared to DSB (Double Side Band) owing to its half bandwidth structure.

In general, SSB transmissions employ the USB (Upper Side Band) modulation, while amateur band transmissions below 10 MHz employ the LSB (Lower Side Band) modulation.

Conventional radios without a BFO (Beat Frequency Oscillator) circuit cannot receive SSB transmissions successfully. This unit can receive SSB transmissions successfully with the built-in BFO (Beat Frequency Oscillator) circuit.

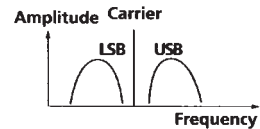

What is CW (Continuous Wave)?

CW is also popular among ham and business radio transmissions. Unlike other signals, the amplitude of a carrier is not modulated for CW transmissions. CW transmissions convey information by interrupting the carrier and use Morse code as a means of communication.

This unit can receive CW transmissions successfully with the built-in BFO (Beat Frequency Oscillator) circuit as beat sound only. To fully comprehend the information transmitted by CW transmissions, an understanding of the Morse code is prerequisite.

What is synchronous detection?

There are two underlying obstacles in optimum AM reception: distortions due to fading and interferences from adjacent broadcast stations.

Synchronous detection is effective in solving these obstacles.

Distortions due to fading are generally caused by over-modulation which occurs when a carrier component of the received signal is attenuated along the way. The synchronous detection circuit of this unit generates a pure carrier frequency with no level variation which is ideally synchronized with the original carrier to compensate for the attenuated carrier component, thus dramatically reducing distortion.

Likewise, AM (LW, MW, and SW) broadcast generally employs DSB (Double Side Band) signals for transmissions in which the modulated signals are transmitted using both the upper and lower side bands (USB and LSB). In most cases, one of the side bands is affected by interferences from adjacent broadcast stations (i.e., beats). The synchronous detection circuit of this unit extracts one of the two sides (USB or LSB) of the DSB

(Double Side Band) signal which is free from interferences. This allows clear reception without the interferences from adjacent broadcast stations.

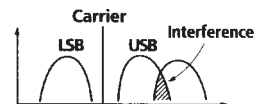

SECTION 3 DISASSEMBLY

- The equipment can be removed using the following procedure.

<RADIO SECTION>

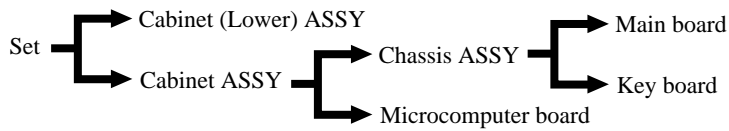

<ANTENNA CONTROLLER SECTION>

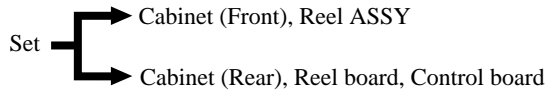

Note : Follow the disassembly procedure in the numerical order given.

<RADIO SECTION>

3-1. CABINET (LOWER), CABINET ASSY

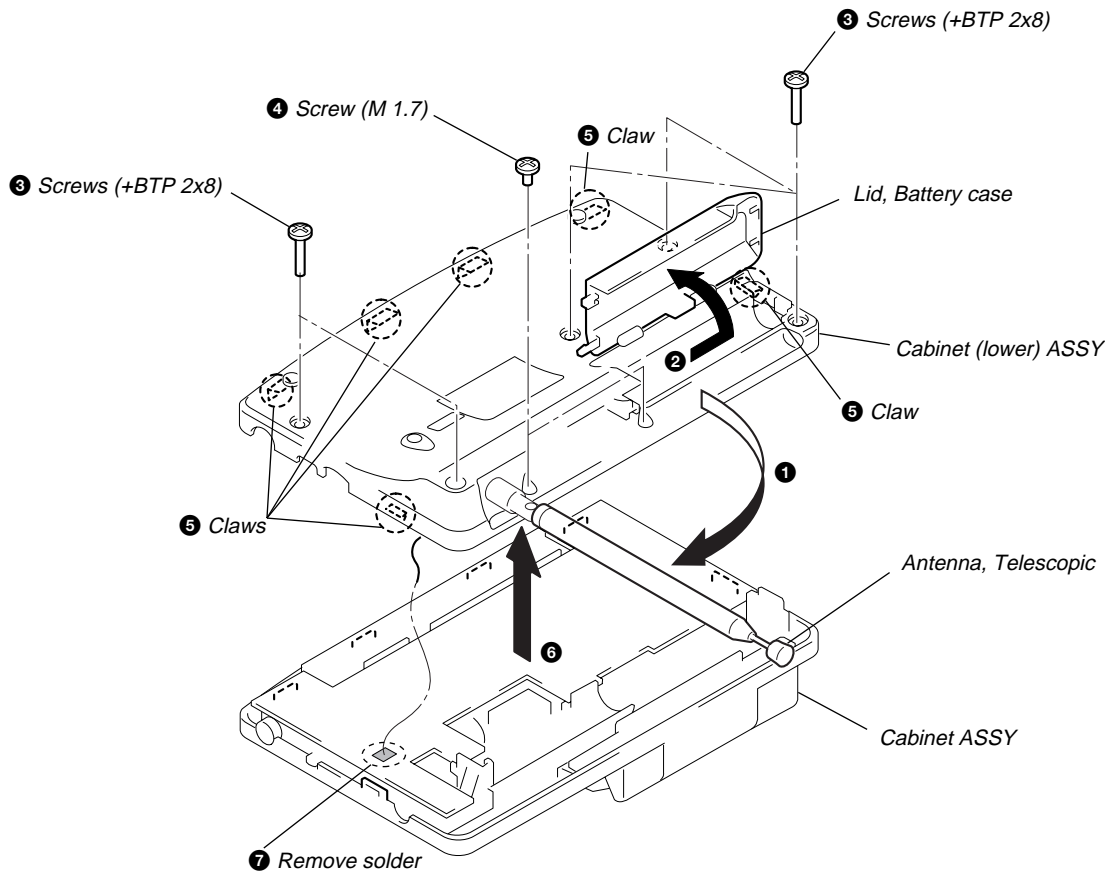

3-2. CHASSIS ASSY

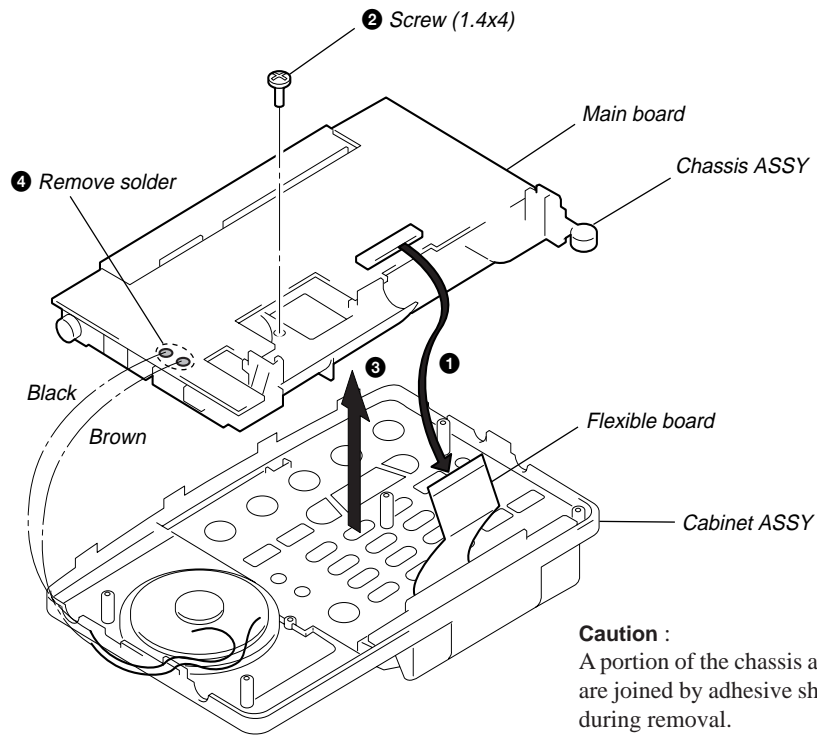

3-3. MAIN BOARD

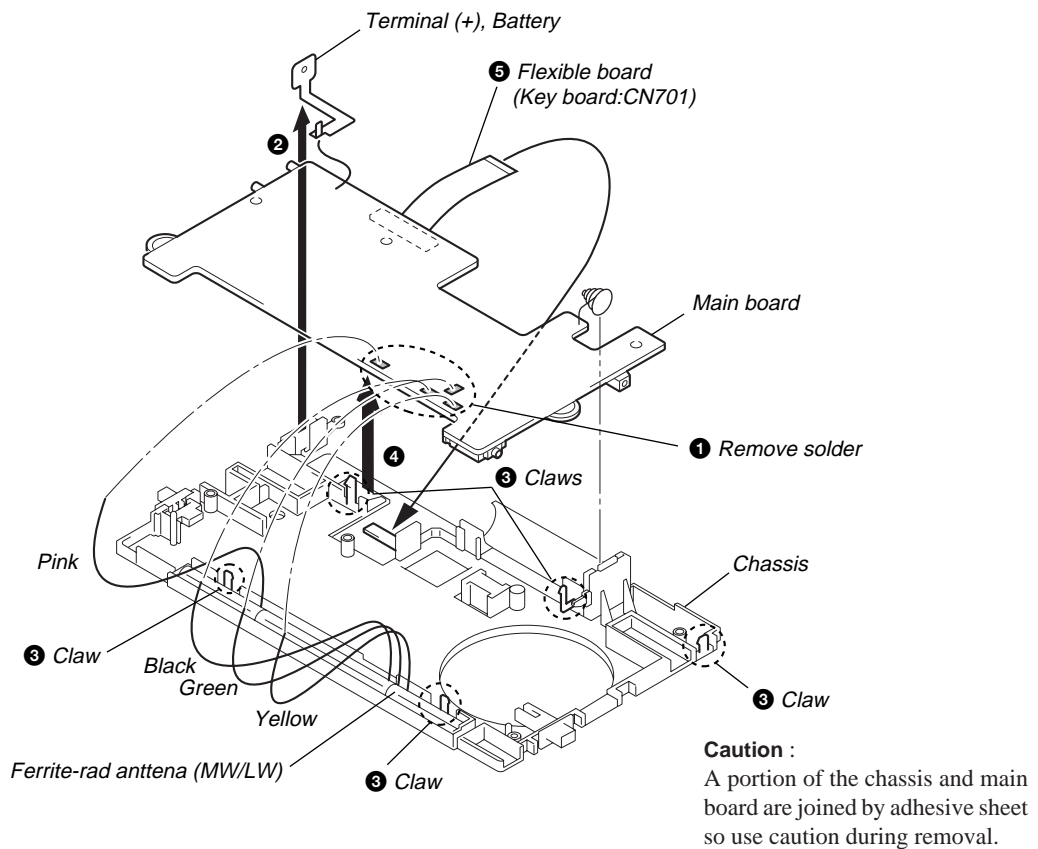

3-4. KEY BOARD

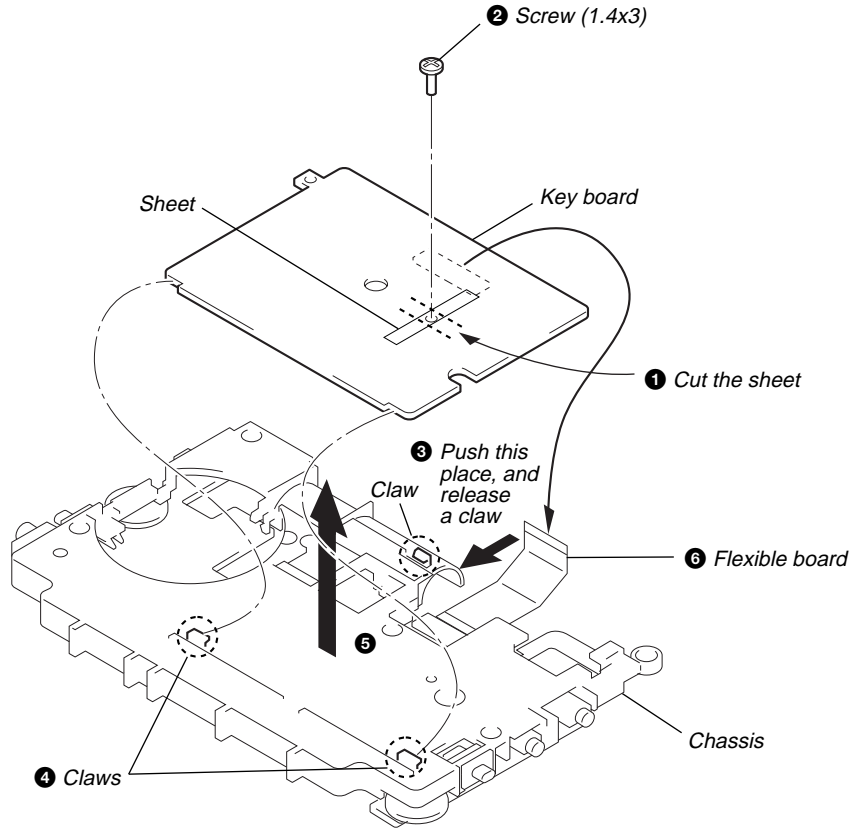

3-5. MICROCOMPUTER BOARD

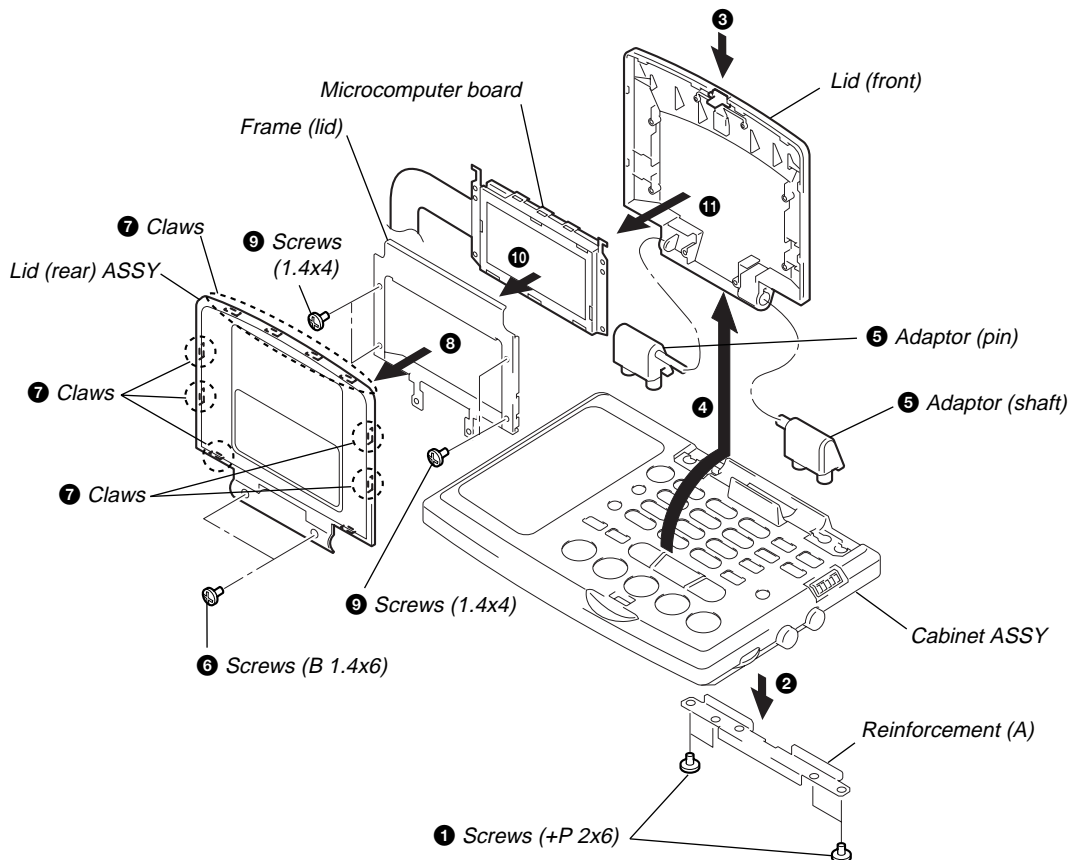

<ANTENNA CONTROLLER SECTION>

3-6. CABINET (FRONT), REEL ASSY

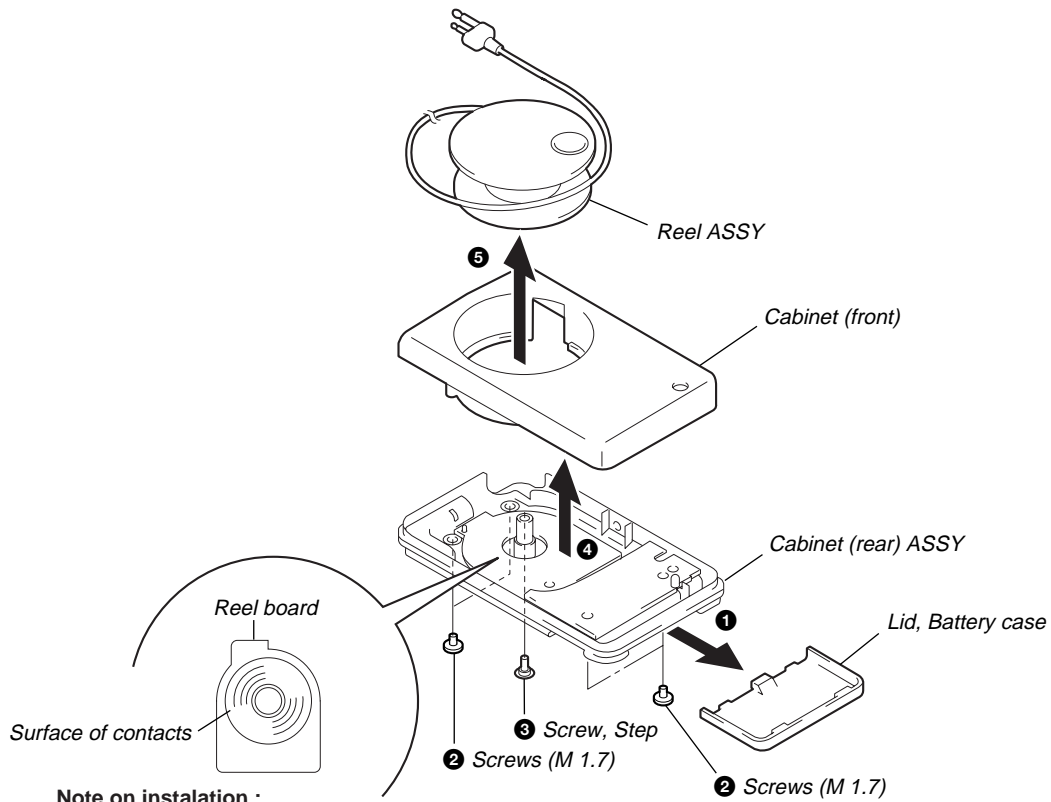

Note on installation :
Apply grease (J-2502-028-1)
to the surface of contacts
on the reel board.

3-7. CABINET (REAR), REEL BOARD, CONTROL BOARD

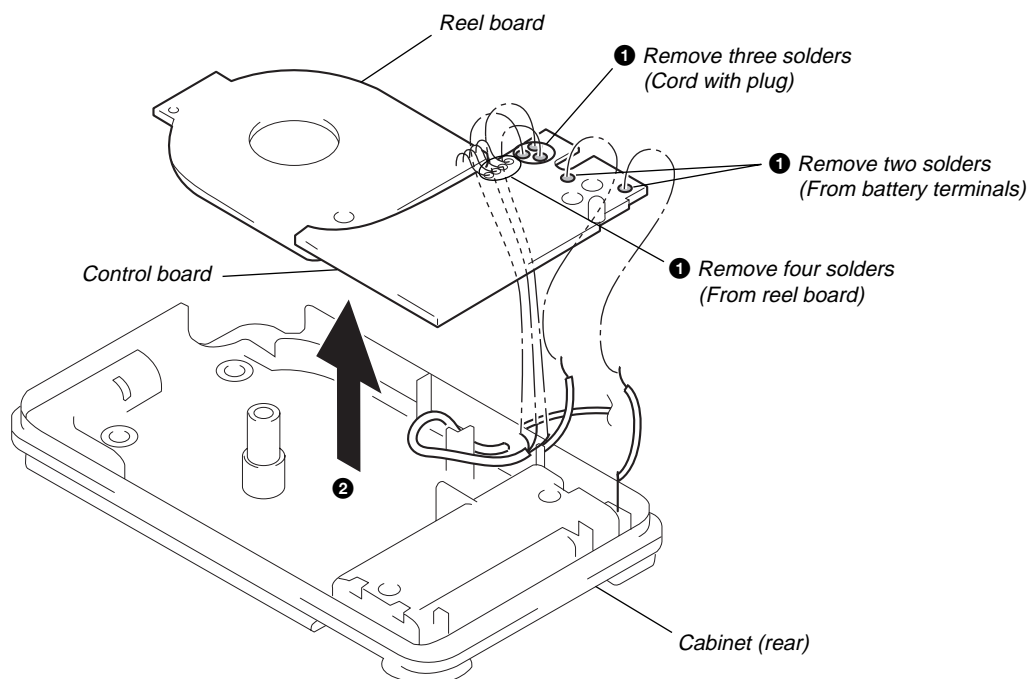

SECTION 4 ELECTRICAL ADJUSTMENTS

AM SECTION 0dB=1μV

2nd LOCAL Adjustment

BAND : AM

VOLUME control : as required

Connection Points :

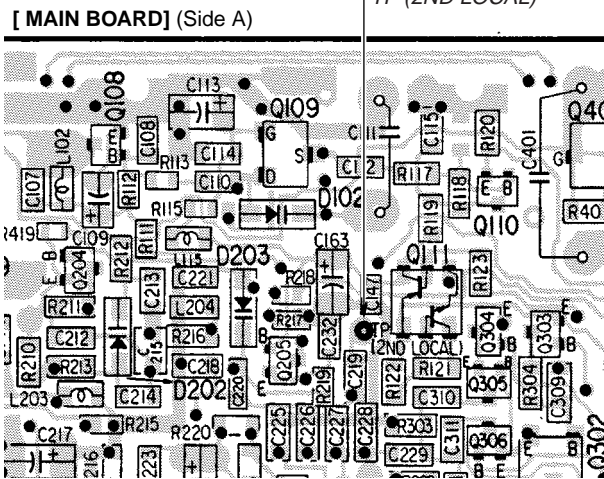
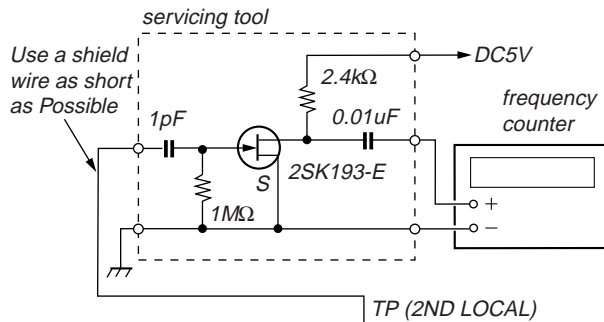

Procedure :

1. Tune the set to AM 150kHz.
2. Press the SSB button, and confirm that USB is displayed.
3. Press the **→|** button.
4. Adjust CT201 to obtain a 55.39MHz on the frequency counter.
Standard value : 55.38997 – 55.39003 MHz
5. Press the **←** button only once. (Return to 2 if wrong)
6. Adjust RV203 to obtain a 55.3891MHz on the frequency counter.
Standard value : 55.38907 – 55.38913 MHz

Adjustments Location : MAIN board (see page 33)

1 st IF Adjustment

BAND : AM

VOLUME control : as required

Setup :

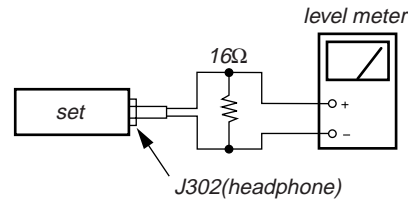
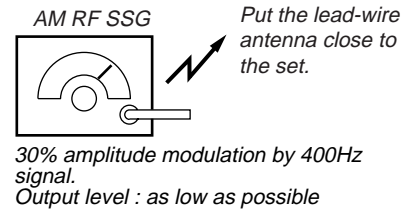

Procedure :

1. Set the frequencies of the AM RF SSG and the frequency display of the set to 150kHz.
2. Adjust T104 and T105 to obtain a maximum reading on the level meter.

Adjustments Location : MAIN board (see page 33)

SSB ZERO BEAT Adjustment

Setup :

BAND : AM

MODE : SSB (USB or LSB/CW)

Procedure :

1. Tune to the strong and stable AM station nearby.
2. Adjust the RV201 to attain zero beat (no beat sound heard).
3. Change the mode to the alternative band (LSB/CW if USB), and if not, readjust.

Adjustments Location : MAIN board (see page 33)

SW FREQUENCY Adjustment

BAND : AM

VOLUME control : as required

Connection Points :

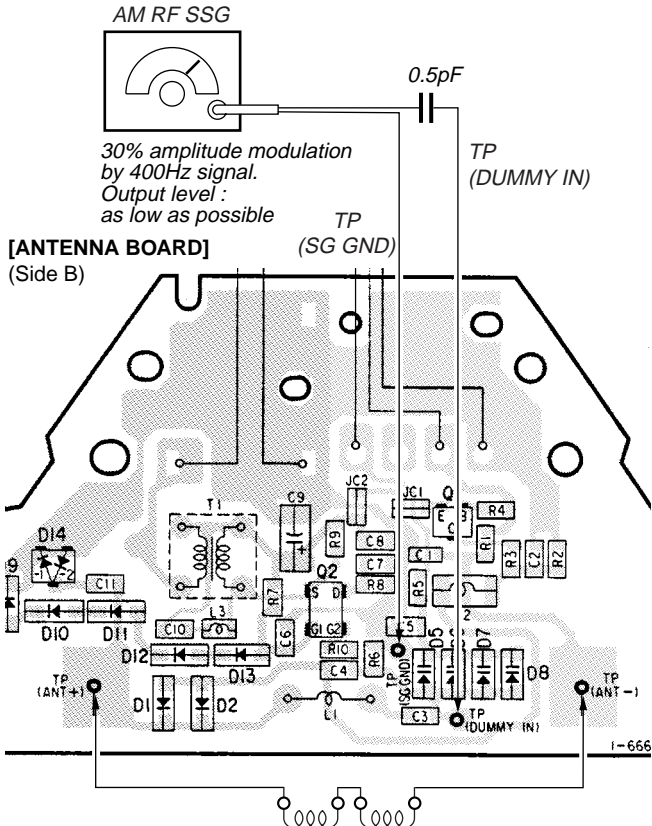

Two dummy antenna coils 1 μ H (1-410-497-11)

Note : Disconnect a loop antenna ASSY from the antenna board, and connect two dummy antenna coils in series connection.

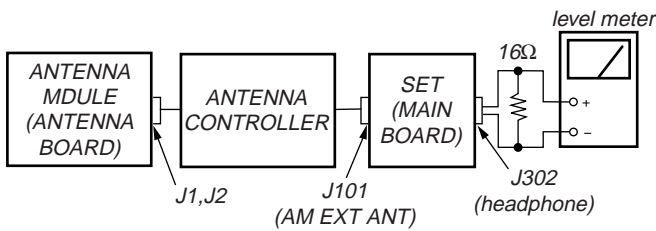

Procedure :

1. Align the set with the frequency of the AM RF signal generator shown on the table below.
2. Align RV401 - RV412 for each band meter band until the highest reading is obtained on the level meter.

AM RF SSG frequency	Meter band	Adjust part
2.4MHz	120mb	RV401
3.3MHz	90mb	RV403
3.95MHz	75mb	RV405
4.9MHz	60mb	RV407
6.075MHz	49mb	RV409
7.25MHz	41mb	RV411
9.7MHz	31mb	RV402
11.825MHz	25mb	RV404
13.7MHz	22mb	RV406
15.35MHz	19mb	RV408
18.275MHz	16mb	RV410
23.5MHz	13mb	RV412

Caution : Always perform the SW Frequency Adjustment after having replace the main circuit board or antenna circuit board.

Adjustments Location : MAIN board (see page 33)

FM SECTION

FM FREQUENCY COVERAGE Adjustment

BAND : FM

VOLUME control : as required

Connection Points :

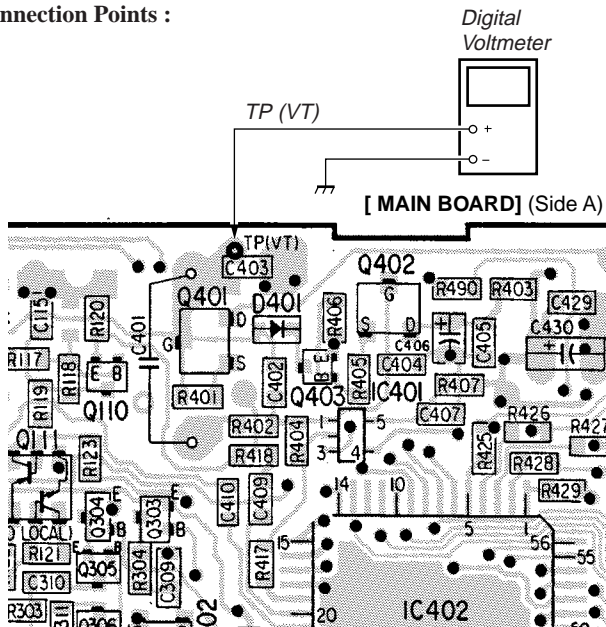

Procedure :

1. Tune the set to 76MHz.
2. Adjust T201 to obtain a 1.6V on the digital voltmeter.
Standard value : 1.55 – 1.65V
3. Tune the set to 108MHz.
4. Make sure that the digital voltmeter reading is below 11V.

Adjustments Location : MAIN board (see page 33)

FM TRACKING Adjustment

Note : This adjustment should be performed after the remove Rod Antenna (ANT102).

This adjustment should be performed after the FM FREQUENCY COVERAGE ADJUSTMENT.

BAND : FM

VOLUME control : as required

Connection Points :

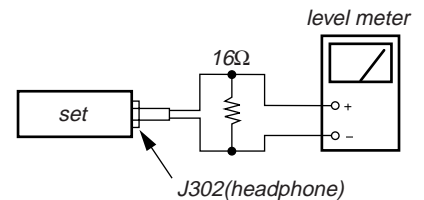
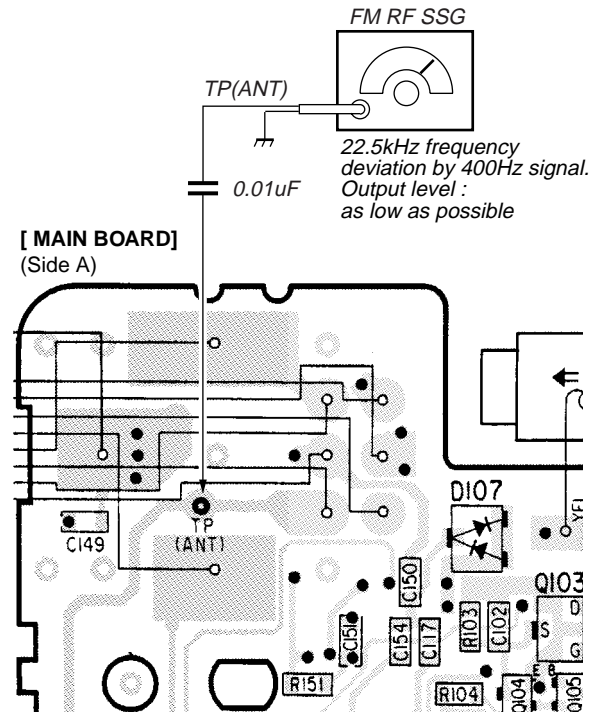

Procedure :

1. Set the frequencies of the FM RF SSG and the frequency display of the set to 76MHz.
2. Adjust T106 and T107 to obtain a maximum reading on the level meter.
3. Set the frequencies of the FM RF SSG and the frequency display of the set to 108MHz.
4. Adjust CT101 and CT102 to obtain a maximum reading on the level meter.
5. Repeat the above steps several times, and finish the adjustment with the trimmers CT101 and CT102.

Adjustments Location : MAIN board (see page 33)

FM STEREO Adjustment

BAND : FM

ST • MONO switch : ST

VOLUME control : as required

Connection Points :

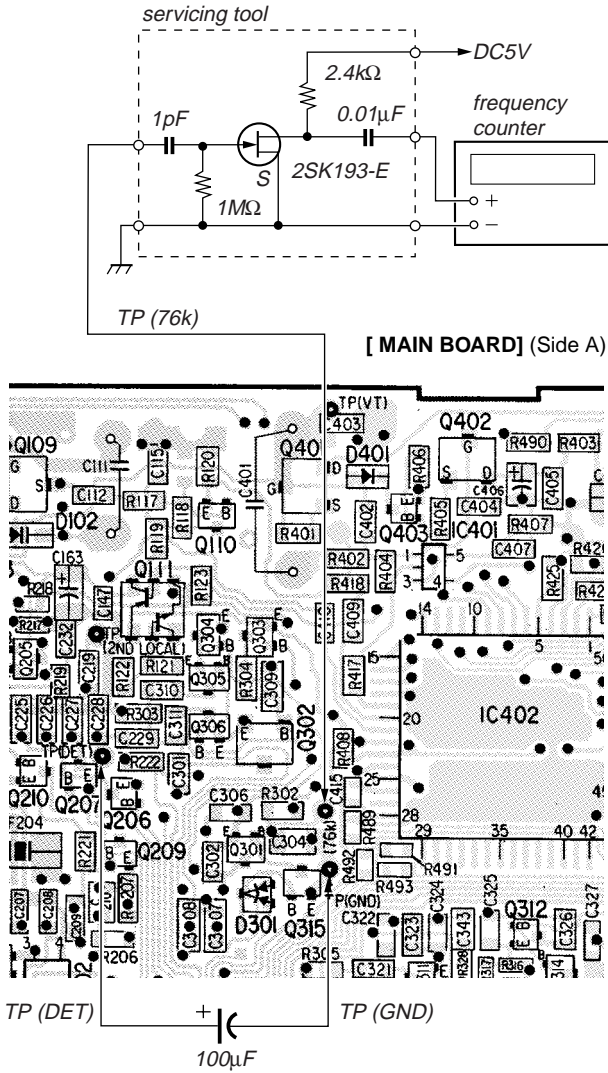

Note : Connect a capacitor (100μF) to TP (DET) during TP (GND).

Procedure :

1. Adjust RV301 to obtain a 76kHz on the frequency counter.
Standard value : 75.7 – 76.3MHz

Adjustments Location : MAIN board (see page 33)

SD Adjustment

BAND : FM

VOLUME control : as required

Connection Points :

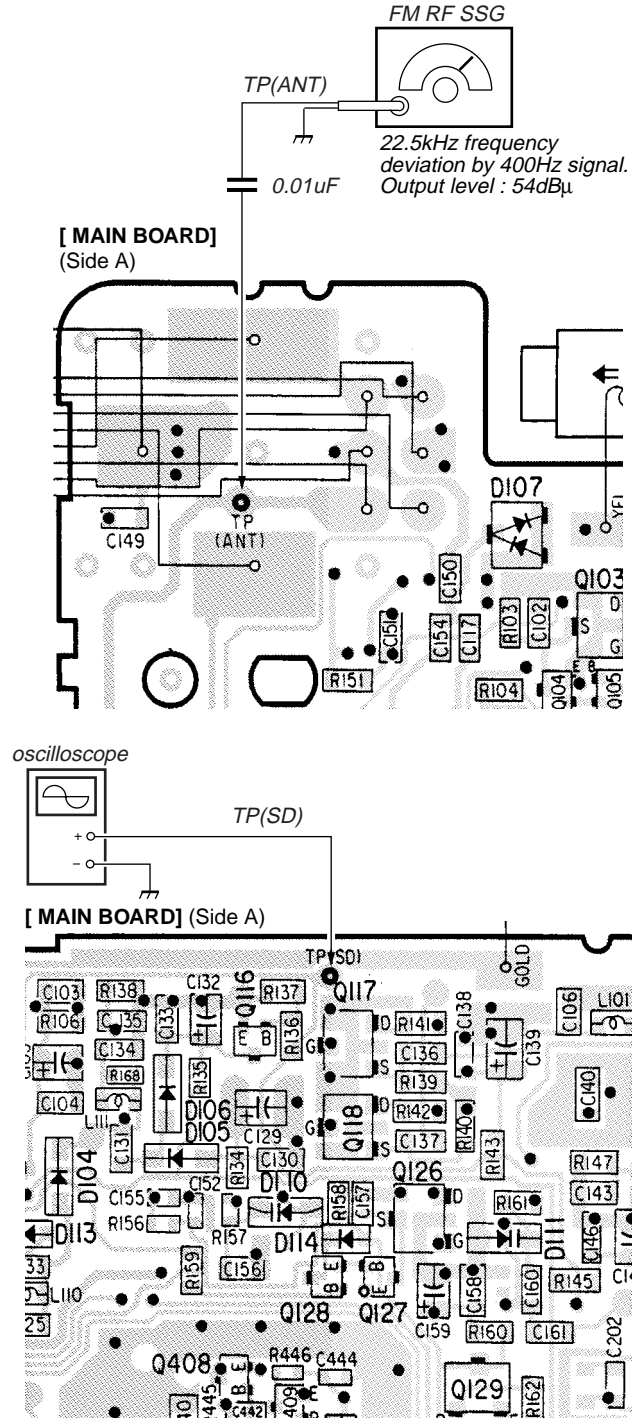

Procedure :

1. Set the frequencies of the FM RF SSG and the frequency display of the set to 93MHz.
2. Adjust RV202 so that a waveform on oscilloscope is as shown below.

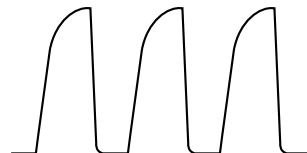

Adjustments Location : MAIN board (see page 33)

FM 100MHz Adjustment

BAND : FM

VOLUME control : as required

Connection Points :

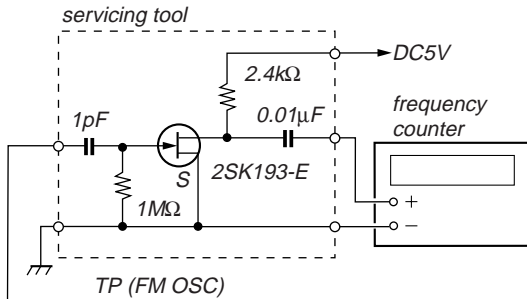

[MAIN BOARD] (Side A)

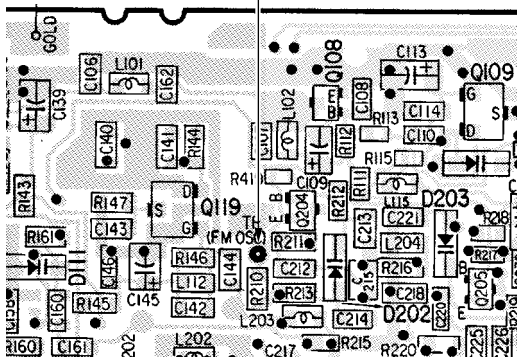

Procedure :

1. Tune the set to FM 89.3MHz.
2. Adjust CT401 to obtain a 100MHz on the frequency counter.
Standard value : 99.99997 – 100.00003MHz

Adjustments Location : MAIN board

MICROCOMPUTER SECTION

4MHz SYSTEM CLOCK Adjustment

BAND : AM

VOLUME control : as required

Connection Points :

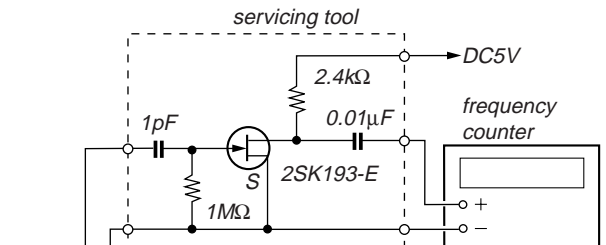

[MICROCOMPUTER BOARD] (Side A)

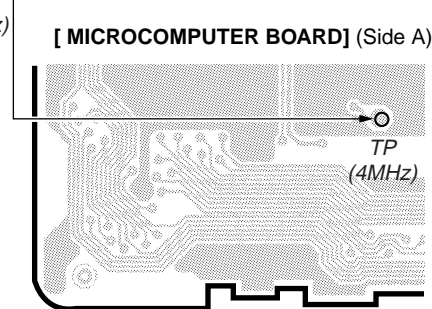

Procedure :

1. Tune the set to AM 150kHz.
2. Adjust CT501 to obtain a 4.04MHz on the frequency counter.
Standard value : 4.038 – 4.042MHz
3. Tune the set to AM 1010kHz.
4. Make sure that the frequency counter reading is 3.9670 – 3.9730 MHz

Adjustments Location :

[MICROCOMPUTER BOARD] (SIDE B)

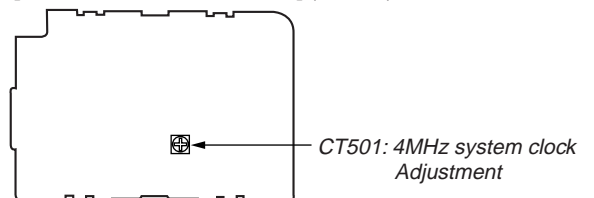

Adjustments Location :

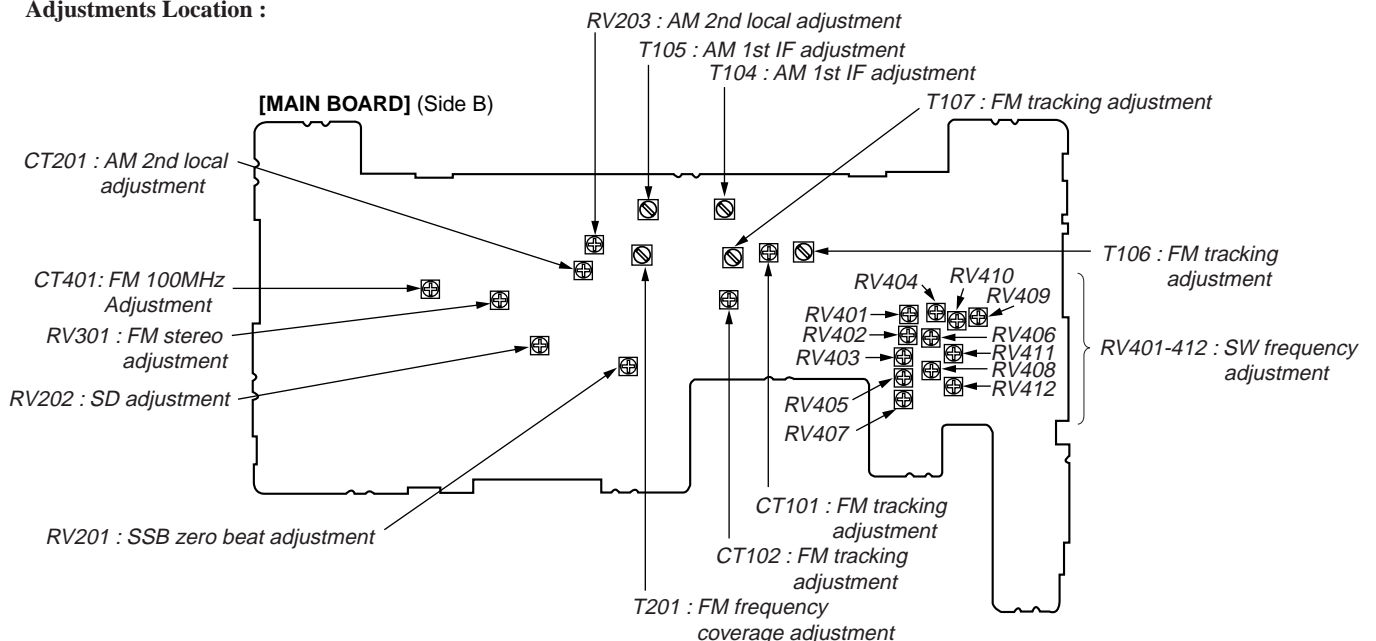

SECTION 5 DIAGRAMS

5-1. EXPLANATION OF IC TERMINALS

IC402 μ PD17072GB-556-1A7 (PLL SYNTHESIZER CONTROL)

Pin No.	Pin name	I/O	Description
1	ROD/BAR	O	ROD/BAR antenna select output. "H" : BAR, "L" : ROD
2	AM/FM	O	AM/FM select output. "H" : AM, "L" : FM
3	ENV/PSN	O	ENV/PSN select output. "H" : ENV, "L" : PSN
4	SSB/SYNC	O	SSB/SYNC select output. "H" : SSB, "L" : SYNC
5	L/U	O	USB/LSB select output.
6	BAND0	O	Meter band select output.
7	BAND1	O	Meter band select output.
8	BAND2	O	Meter band select output.
9	BAND3	O	Meter band select output.
10 – 13	——	–	Not used (OPEN).
14	DA0	I/O	DA signal in/out terminal.
15	DA1	I/O	DA signal in/out terminal.
16	DA2	I/O	DA signal in/out terminal.
17	DA3	I/O	DA signal in/out terminal.
18	GND	–	Ground terminal.
19	EO	O	PLL charge pump output.
20	VCOL	I	MF, HF input terminal.
21	VCOH	I	VHF input terminal.
22	REGO	O	Regulator output for PLL.
23	VDD	–	Power supply terminal.
24	XOUT	O	Oscillator output terminal (75kHz).
25	XIN	I	Oscillator input terminal (75kHz).
26	REG1	O	Regulator output for oscillator.
27 – 49	——	–	Not used (OPEN).
50	CE	I	Chip enable input.
51	REQ	I	PLL request signal input.
52	PLL-CTL	O	PLL control output.
53	UNLOCK	O	PLL unlock signal output.
54	ACK	O	Clock signal output for system control (IC501).
55	SCK	O	Clock signal output for sub system control (IC502).
56	SI	I	Data signal input for sub system control (IC502).

IC501 μ PD753017AGK-717-BE9 (MAIN SYSTEM CONTROL, LCD DRIVE)

Pin No.	Pin name	I/O	Description
1 – 12	S12 – 23	O	LCD segment signal output.
13 – 16	—	–	Not used (OPEN).
17	XTAL-CTL	O	Level shift control output for system clock.
18	BEEP-CTL	O	Beep signal control output.
19	IF-POWER	O	IF B+ ON/OFF control output.
20	AF-POWER	O	Power amp ON/OFF control output.
21	COM0	O	LCD common signal output.
22	COM1	O	LCD common signal output.
23	COM2	O	LCD common signal output.
24	COM3	O	LCD common signal output.
25	BIAS	O	Bias output for LCD.
26	VLC0	–	LCD drive power supply.
27	VLC1	–	LCD drive power supply.
28	VLC2	–	LCD drive power supply.
29	SD	I	SD signal input terminal.
30	TUNE	I	TUNE signal input terminal.
31	—	–	Connect to VDD.
32	HOLD	I	Hold switch input.
33	GND	–	Ground terminal.
34	MUTE	O	Mute signal output.
35	SET	–	Not used (OPEN).
36	REQ-SUB	O	Request signal output for sub system control.
37	REQ-DTS	O	DTS request signal output for PLL.
38	VDET-1	I	Power voltage detect input.
39	SCK	I	Sub clock signal input.
40	SO	O	Data signal output.
41	SI	I	Data signal input.
42	ACK	I	Clock signal input from PLL.
43	VDET2	I	Power voltage detect input.
44	UNLOCK	I	PLL unlock detect input.
45	CARD	–	Connect to ground.
46	—	–	Not used (OPEN).
47	CS1	O	Chip select output for ROM.
48	BEEP	O	Beep signal output.
49	CS0	O	Chip select signal output.
50	KS0	I	Key input.
51	KS1	I	Key input.
52	KS2	I	Key input.
53	KS3	I	Key input.
54	VDD	–	Power supply terminal.
55	XT1	I	Sub clock input (32.768kHz).
56	XT2	O	Sub clock output (32.768kHz).
57	IC	–	Connect to VDD.
58	X1	I	Main system clock input (4MHz).
59	X2	O	Main system clock output (4MHz).
60 – 67	KR0 – KR7	I	Key input terminal.
68	RESET	I	System reset input. “L” : Reset
69 – 80	S0 – S11	O	LCD segment signal output.

IC502 μ PD753012AGK-781-BE9 (SUB SYSTEM CONTROL, LCD DRIVE)

Pin No.	Pin name	I/O	Description
1 – 18	S12 – S29	O	LCD segment signal output.
19, 20	—	–	Not used (OPEN).
21	COM0	O	LCD common signal output.
22	COM1	O	LCD common signal output.
23	COM2	O	LCD common signal output.
24	COM3	O	LCD common signal output.
25	BIAS	O	Bias output for LCD.
26	VLC0	–	LCD drive power supply.
27	VLC1	–	LCD drive power supply.
28	VLC2	–	LCD drive power supply.
29 – 37	—	–	Not used (Connect to GND).
38	REQ	I	Request signal input.
39	SCK	I	Sub clock input.
40	—	–	Not used (fix to “L”).
41	SI	I	Data signal input.
42 – 45	—	–	Not used (Connect to GND).
46	ACK	O	PLL clock signal control output.
47 – 53	—	–	Not used (OPEN).
54	VDD	–	Power supply terminal.
55	XT1	I	Sub clock input (32.768kHz).
56	XT2	O	Sub clock output (32.768kHz).
57	IC	–	Connect to VDD.
58	X1	I	System main clock input (4MHz).
59	X2	O	System main clock output (4MHz).
60 – 67	—	–	Not used (OPEN).
68 – 80	S0 – S11	O	LCD segment signal output.

● **Circuit Boards Location**

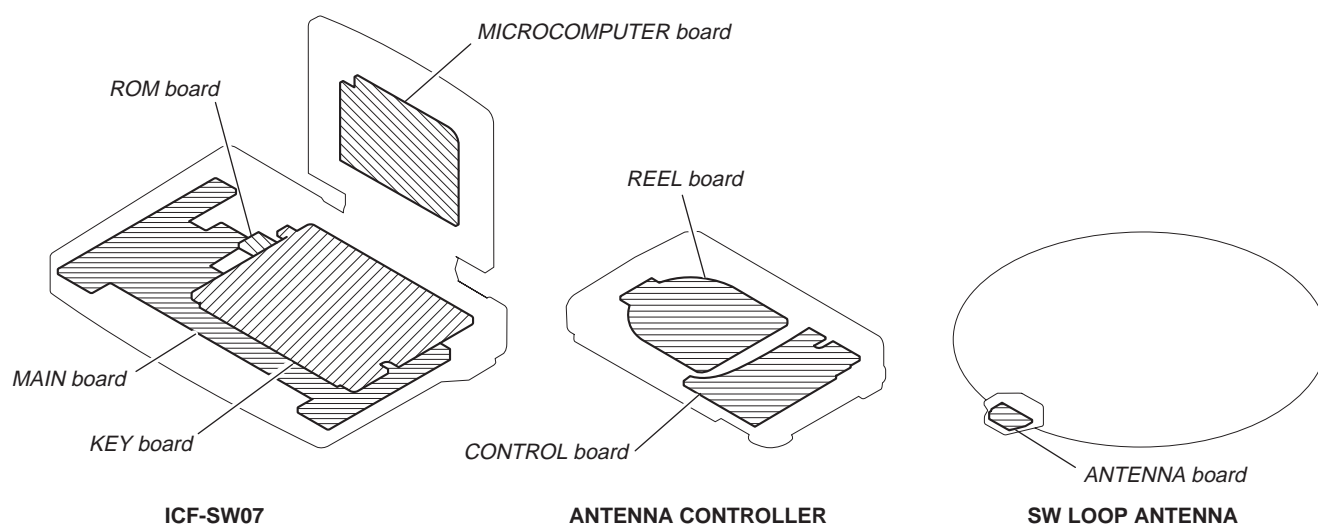

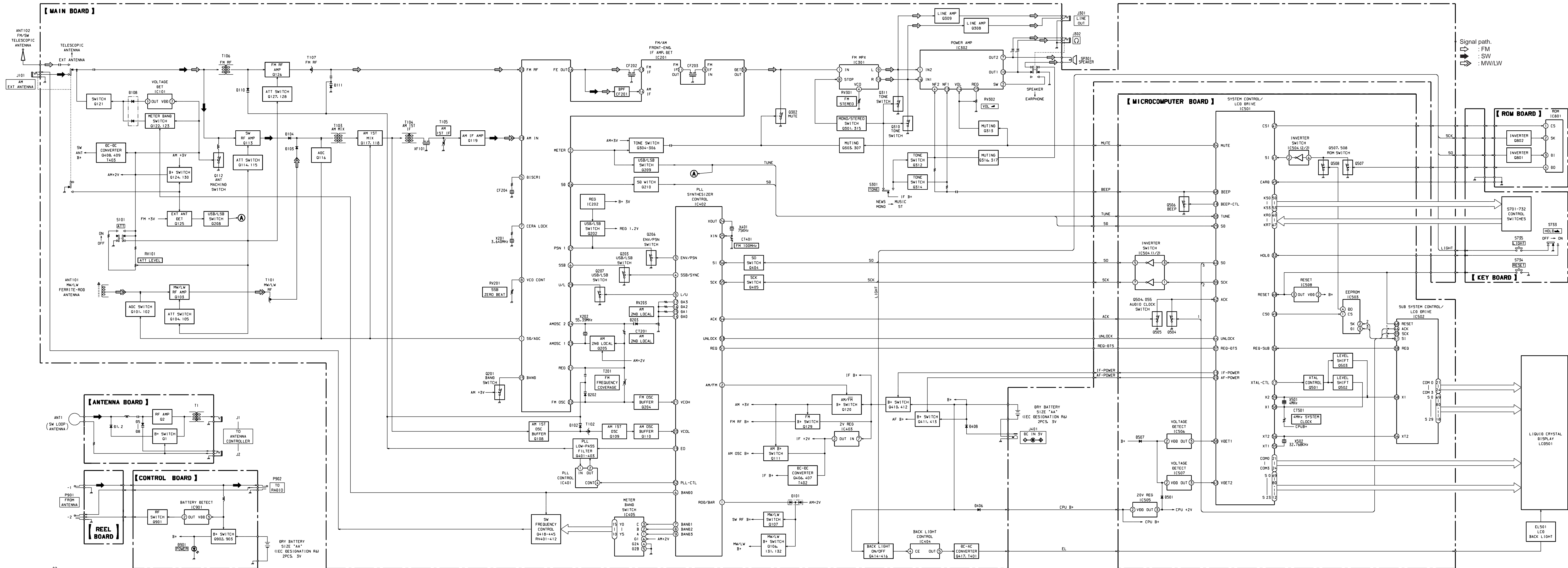

● Semiconductor Location

Ref. No.	Location	Ref. No.	Location
D101	C-22	Q202	D-7
D102	B-8	Q203	D-7
D103	B-21		
D104	B-4	Q204	B-7
D105	B-4	Q205	C-8
		Q206	C-8
D106	B-4	Q207	C-8
D107	B-3	Q208	D-16
D108	C-22		
D109	C-2	Q209	D-8
D110	C-5	Q210	C-8
		Q301	D-8
D111	C-6	Q302	C-9
D112	B-3	Q303	C-8
D113	C-4		
D114	C-5	Q304	C-8
D201	D-9	Q305	C-8
		Q306	C-8
D202	C-7	Q307	D-16
D203	B-7	Q308	D-11
D301	D-8		
D401	B-9	Q309	D-11
D402	C-11	Q310	D-9
		Q311	D-9
D403	C-11	Q312	D-10
D404	D-5	Q313	E-9
D405	D-5		
D406	E-10	Q314	D-10
D407	E-2	Q315	D-9
		Q316	E-10
D408	F-23	Q317	D-10
		Q401	B-9
IC101	C-22	Q402	B-9
IC201	C-17	Q403	B-9
IC202	D-8	Q404	C-15
IC301	D-16	Q405	C-15
IC302	D-15	Q406	C-11
IC401	B-9	Q407	C-11
IC402	C-9	Q408	C-5
IC403	B-15	Q409	C-5
IC404	E-7	Q410	E-16
		Q411	E-10
IC405	D-21		
		Q412	E-16
		Q413	E-10
Q101	B-4	Q414	E-7
Q102	B-4	Q415	E-7
Q103	B-3	Q416	E-7
Q104	B-3		
Q105	B-3	Q417	E-6
		Q418	C-2
Q106	B-22	Q419	D-2
Q107	B-21	Q420	C-2
Q108	B-7	Q421	C-3
Q109	B-8		
Q110	B-8	Q422	C-2
		Q423	C-3
Q111	B-8	Q424	C-3
Q112	C-3	Q425	D-3
Q113	C-4	Q426	D-3
Q114	C-4		
Q115	C-4	Q427	D-3
		Q428	D-3
Q116	B-5	Q429	D-3
Q117	B-5	Q430	D-3
Q118	B-5	Q431	C-2
Q119	B-6		
Q120	D-6	Q432	C-3
		Q433	D-2
Q121	B-22	Q434	D-3
Q122	C-22	Q435	D-2
Q123	C-22	Q436	D-3
Q124	C-22		
Q125	C-22	Q437	D-3
		Q438	D-3
Q126	C-5	Q439	D-2
Q127	C-5	Q440	D-3
Q128	C-5	Q441	D-3
Q129	C-6		
Q130	C-2	Q442	D-3
		Q443	D-4
Q131	B-21	Q444	D-4
Q132	C-21	Q445	D-4
Q201	D-6		

Note:

- ◯ : parts extracted from the component side.
- ● : Through hole.
- ◻ : Pattern from the side which enables seeing.
(The other layers' patterns are not indicated.)

Caution:
 Pattern face side: Parts on the pattern face side seen from the pattern face are indicated.
 (Side A)
 Parts face side: Parts on the parts face side seen from the parts face are indicated.
 (Side B)

5-4. SCHEMATIC DIAGRAM (MAIN SECTION) Refer to page 63 for IC Block Diagrams.

VOLTAGE VALUES OF IC402 PINS ON CONNECTING AM EXT ANTENNA (SW RECEPTION)

Table with 12 columns (Pin No., 11mb, 13mb, 15mb, 16mb, 19mb, 22mb, 25mb, 31mb, 41mb, 49mb, 60mb, 75mb, 90mb, 120mb) and 9 rows of voltage values.

VOLTAGE VALUES OF IC405 ON CONNECTING AM EXT ANTENNA (SW RECEPTION)

Table with 12 columns (Pin No., 11mb, 13mb, 15mb, 16mb, 19mb, 22mb, 25mb, 31mb, 41mb, 49mb, 60mb, 75mb, 90mb, 120mb) and 16 rows of voltage values.

VOLTAGE VALUES OF TRANSISTORS Q418 - 445 ON CONNECTING AM EXT ANTENNA (SW RECEPTION)

Large table with 12 columns (SW, 11mb, 13mb, 15mb, 16mb, 19mb, 22mb, 25mb, 31mb, 41mb, 49mb, 60mb, 75mb, 90mb, 120mb) and 48 rows of voltage values for various transistors.

Waveforms (MAIN Section)

- Note: All capacitors are in μF unless otherwise noted. pF: μμF 50 WV or less are not indicated except for electrolytics and tantalums. All resistors are in Ω and 1/4 W or less unless otherwise specified.

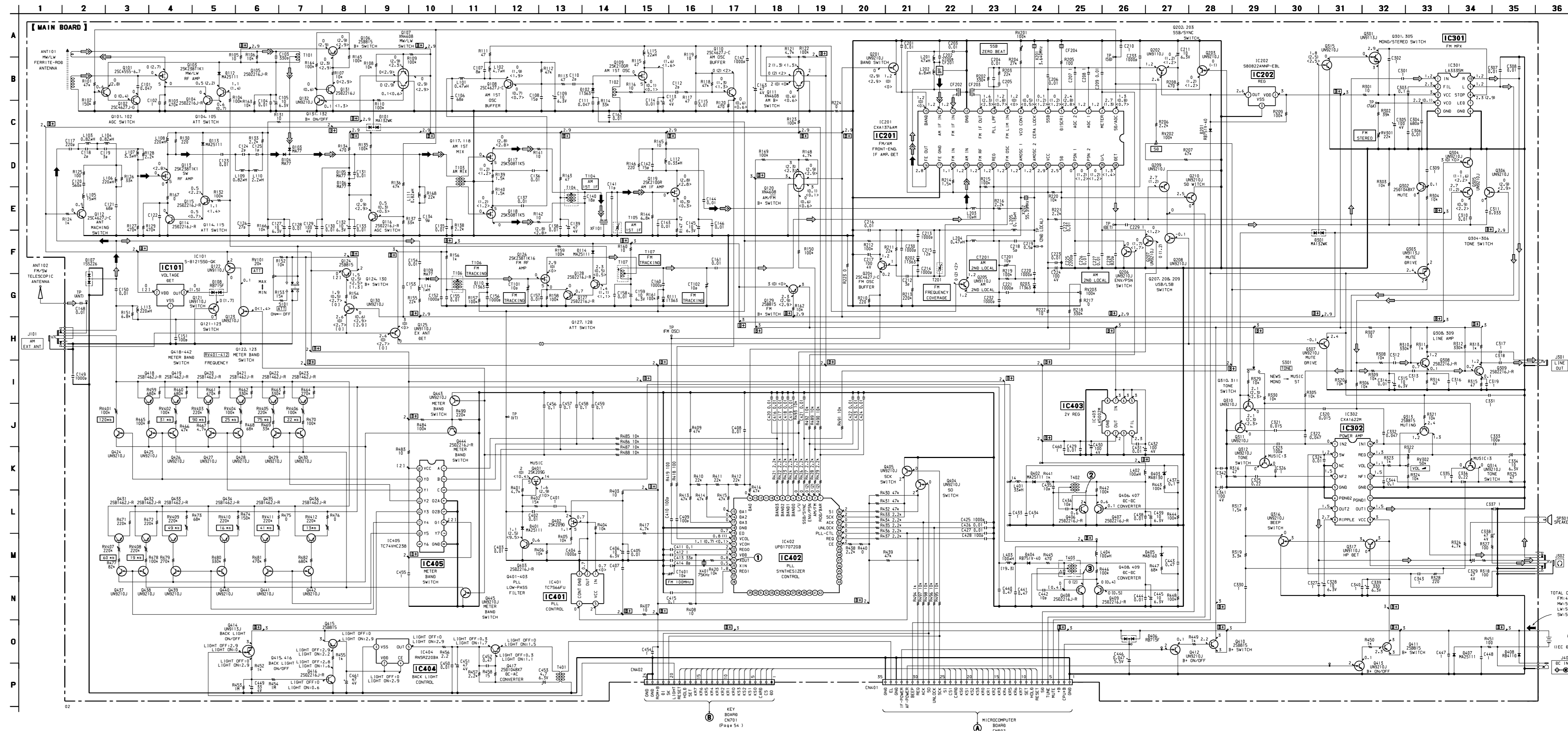
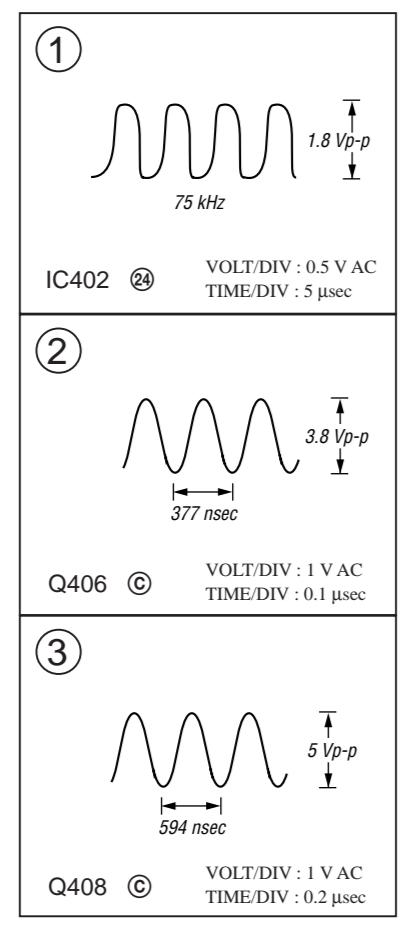

5-5. PRINTED WIRING BOARDS (KEY SECTION)

● Semiconductor Location

Ref. No.	Location
IC801	G-12
Q801	G-12
Q802	G-12

Note:
 ○ : parts extracted from the component side.
 ● : Through hole.
 ▨ : Pattern from the side which enables seeing.
 (The other layers' patterns are not indicated.)

Caution:
 Pattern face side: Parts on the pattern face side seen from the (Side A)
 Parts face side: Parts on the parts face side seen from the (Side B)

5-6. SCHEMATIC DIAGRAM (KEY SECTION)

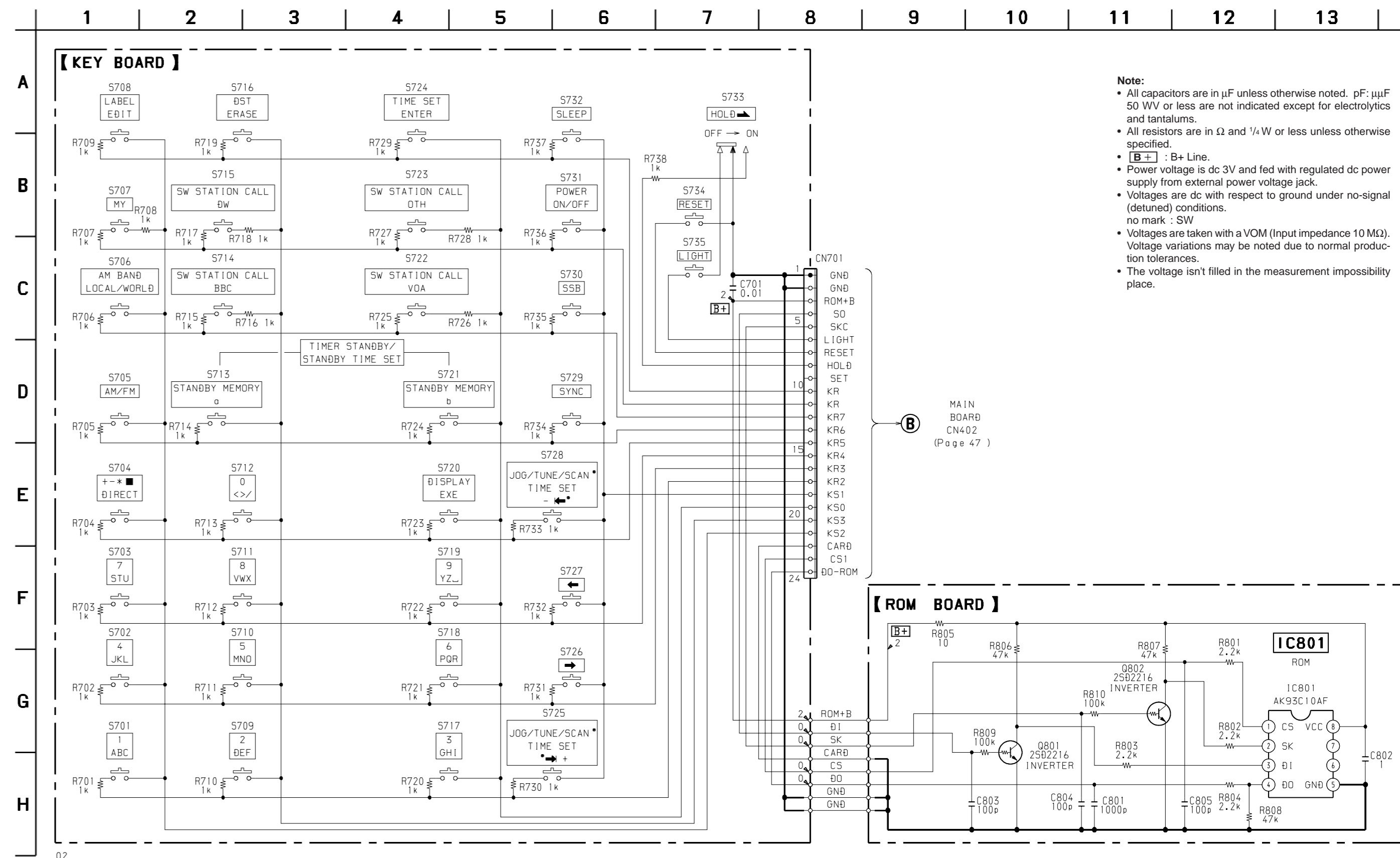

Note:
 • All capacitors are in μF unless otherwise noted. pF : μF
 50 WV or less are not indicated except for electrolytics and tantalums.
 • All resistors are in Ω and $1/4\text{W}$ or less unless otherwise specified.
 • [B+]: B+ Line.
 • Power voltage is dc 3V and fed with regulated dc power supply from external power voltage jack.
 • Voltages are dc with respect to ground under no-signal (detuned) conditions.
 • Voltages are taken with a VOM (Input impedance 10 M Ω). Voltage variations may be noted due to normal production tolerances.
 • The voltage isn't filled in the measurement impossibility place.

● Semiconductor Location

Ref. No.	Location
D501	C-2
D502	D-3
D503	D-3
D504	D-2
D505	D-2
D506	B-2
D507	C-2
IC501	B-3
IC502	C-5
IC503	B-5
IC504	C-2
IC505	B-2
IC506	D-2
IC507	C-3
IC508	D-3
Q501	C-4
Q502	C-4
Q503	C-4
Q504	C-3
Q505	C-3
Q506	C-3
Q507	D-2
Q508	D-2

- Note:
- : parts extracted from the component side.
 - : Through hole.
 - : Pattern of the rear side.
 - : Pattern on the side which is seen.

● Waveform

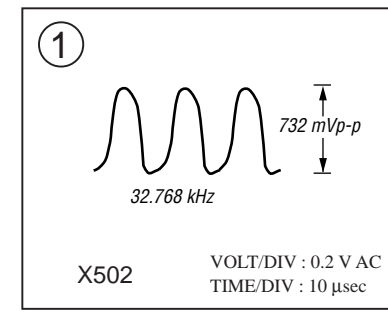

- Note:
- All capacitors are in μF unless otherwise noted. pF: μF 50 WV or less are not indicated except for electrolytics and tantalums.
 - All resistors are in Ω and $1/4$ W or less unless otherwise specified.
 - B+ : B+ Line.
 - : adjustment for repair.
 - Power voltage is dc 3V and fed with regulated dc power supply from external power voltage jack.
 - Voltages and waveforms are dc with respect to ground under no-signal (detuned) conditions. no mark : FM
 - Voltages are taken with a VOM (Input impedance 10 M Ω). Voltage variations may be noted due to normal production tolerances.
 - Waveforms are taken with an oscilloscope. Voltage variations may be noted due to normal production tolerances.
 - Circled numbers refer to waveforms.
 - The voltage isn't filled in the measurement impossibility place.

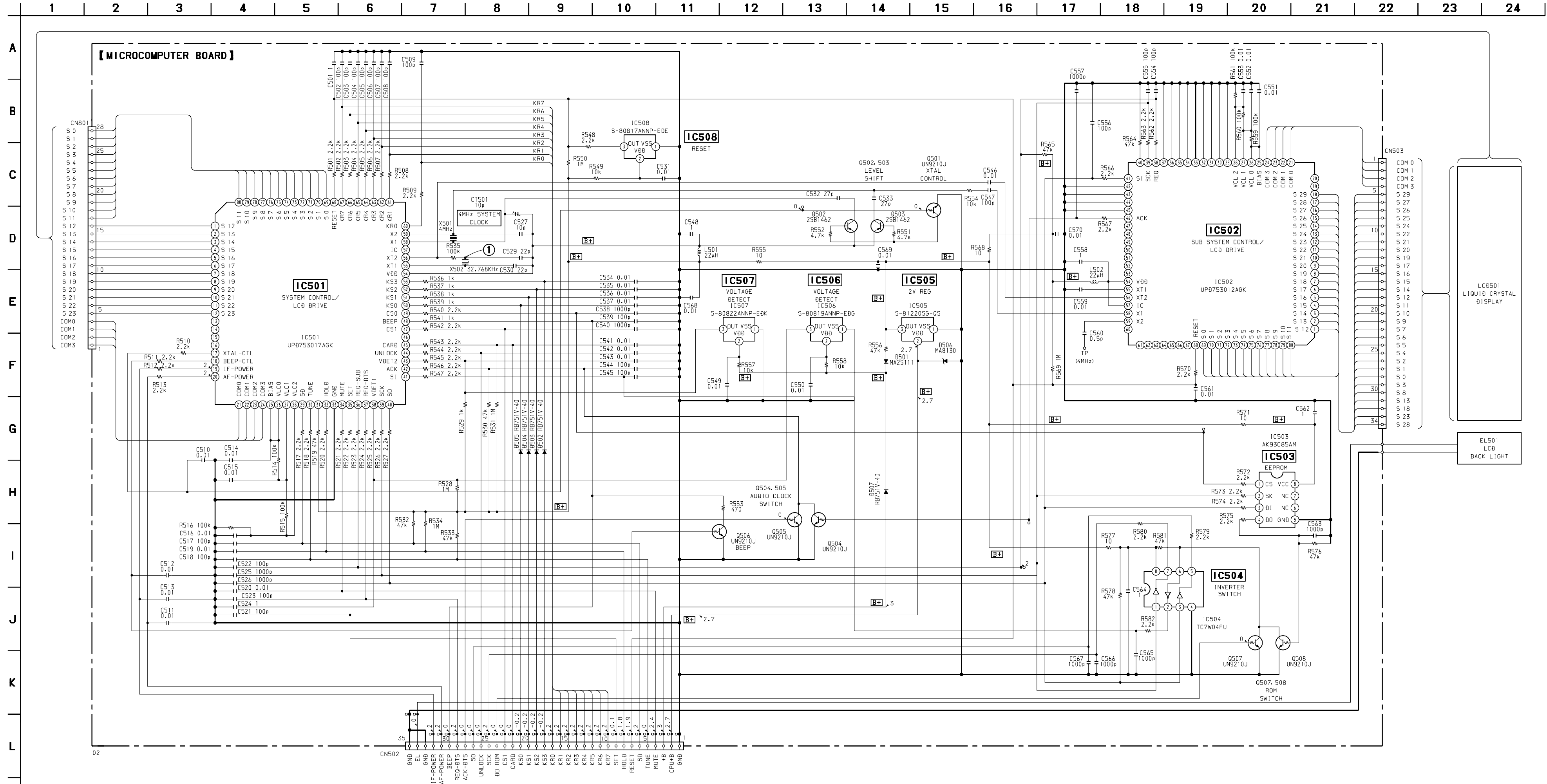

● Semiconductor Location

Ref. No.	Location
D1	I-2
D2	I-2
D5	I-3
D6	I-3
D7	I-3
D8	I-3
D9	I-1
D10	I-1
D11	I-2
D12	I-2
D13	I-2
D14	I-1
D901	B-11
D902	B-9
IC901	C-10
Q1	H-3
Q2	I-3
Q901	C-9
Q902	B-10
Q903	B-10

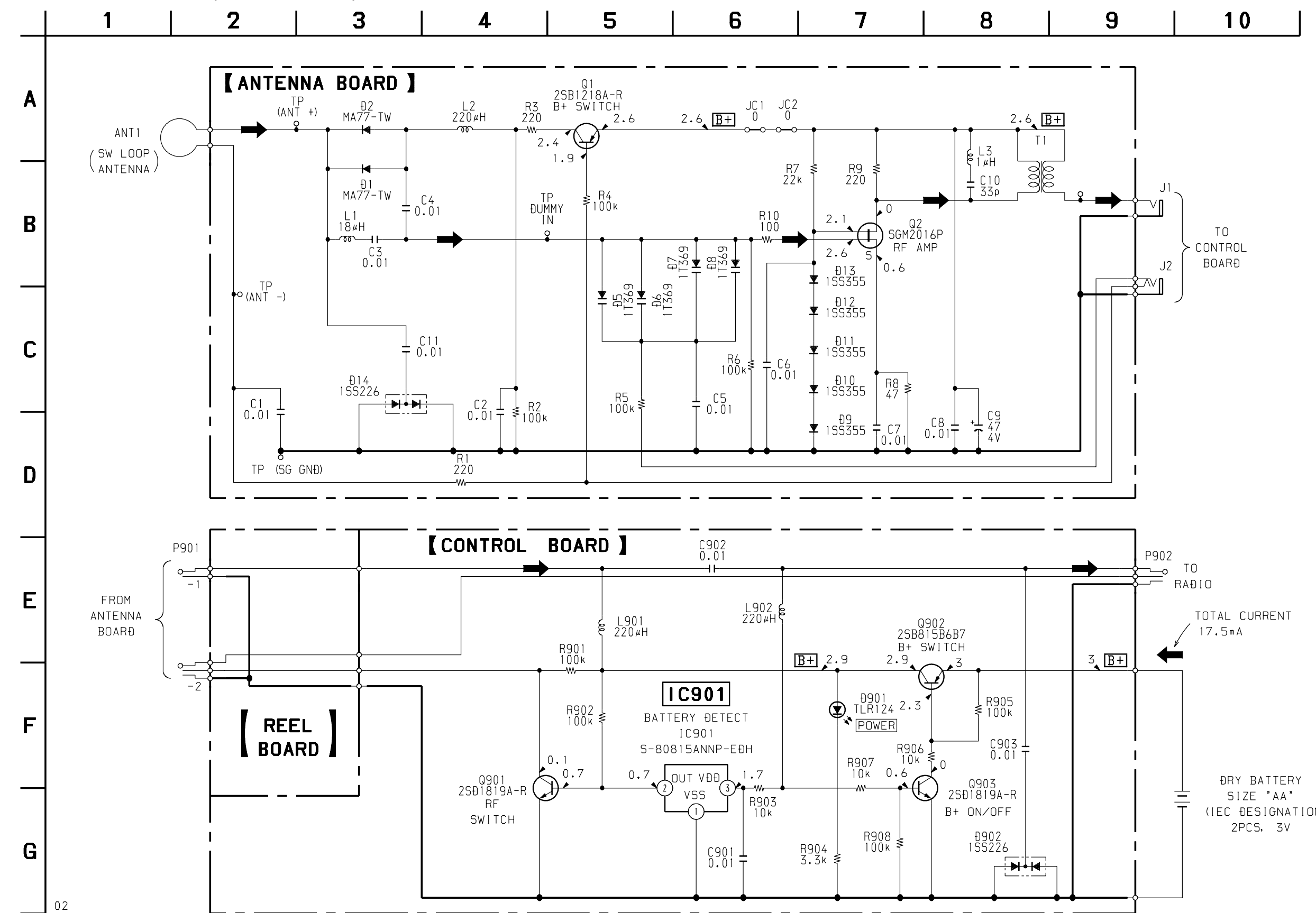

Note:
 ○ : parts extracted from the component side.
 ▨ : Pattern from the side which enables seeing.

Note:
 • All capacitors are in μF unless otherwise noted. pF: μpF
 50 WV or less are not indicated except for electrolytics and tantalums.
 • All resistors are in Ω and $\frac{1}{4}\text{W}$ or less unless otherwise specified.
 • [B+] : B+ Line.
 • Power voltage is dc 3V and fed with regulated dc power supply from external power voltage jack.

• Voltages are dc with respect to ground under no-signal (detuned) conditions.
 no mark : SW
 • Voltages are taken with a VOM (Input impedance 10 M Ω). Voltage variations may be noted due to normal production tolerances.
 • Signal path.
 → : SW

● IC Block Diagrams (MAIN Section)

IC403 LA5002M

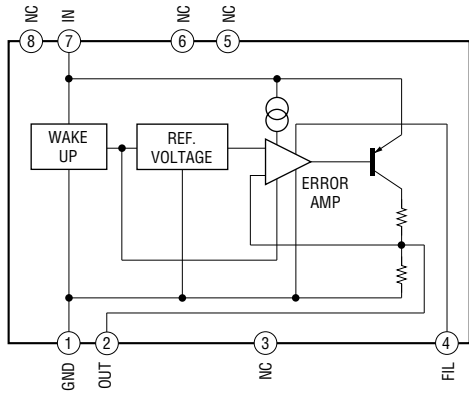

IC201 CXA1376AM

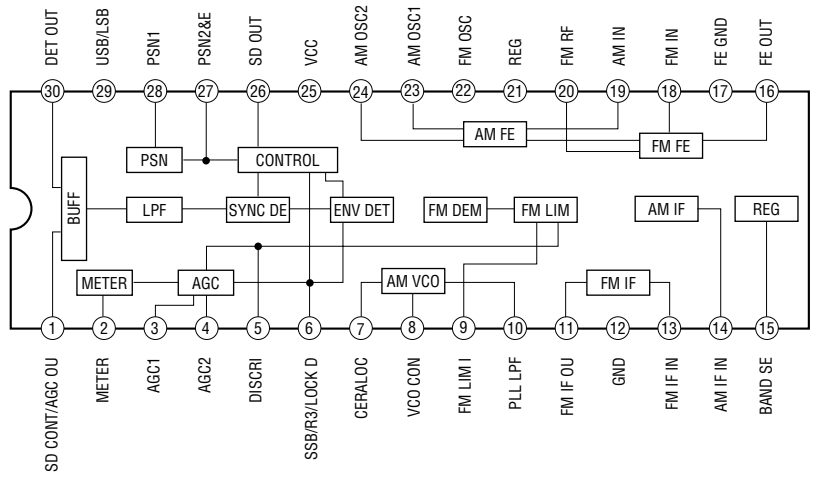

IC301 LA3335M

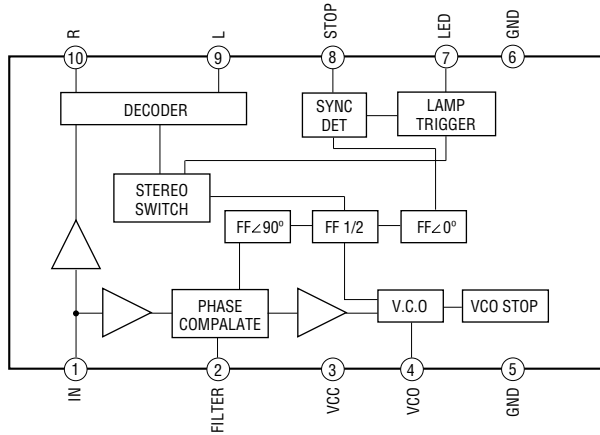

IC302 CXA1622M

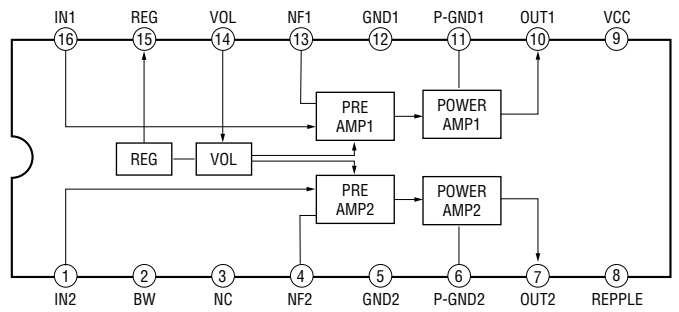

SECTION 6 EXPLODED VIEWS

NOTE :

- -XX, -X mean standardized parts, so they may have some difference from the original one.
- Items marked “ * ” are not stocked since they are seldom required for routine service. Some delay should be anticipated when ordering these items.
- The mechanical parts with no reference number in the exploded views are not supplied
- Accessories and packing materials are given in the last of this parts list.

6-1. CABINET SECTION

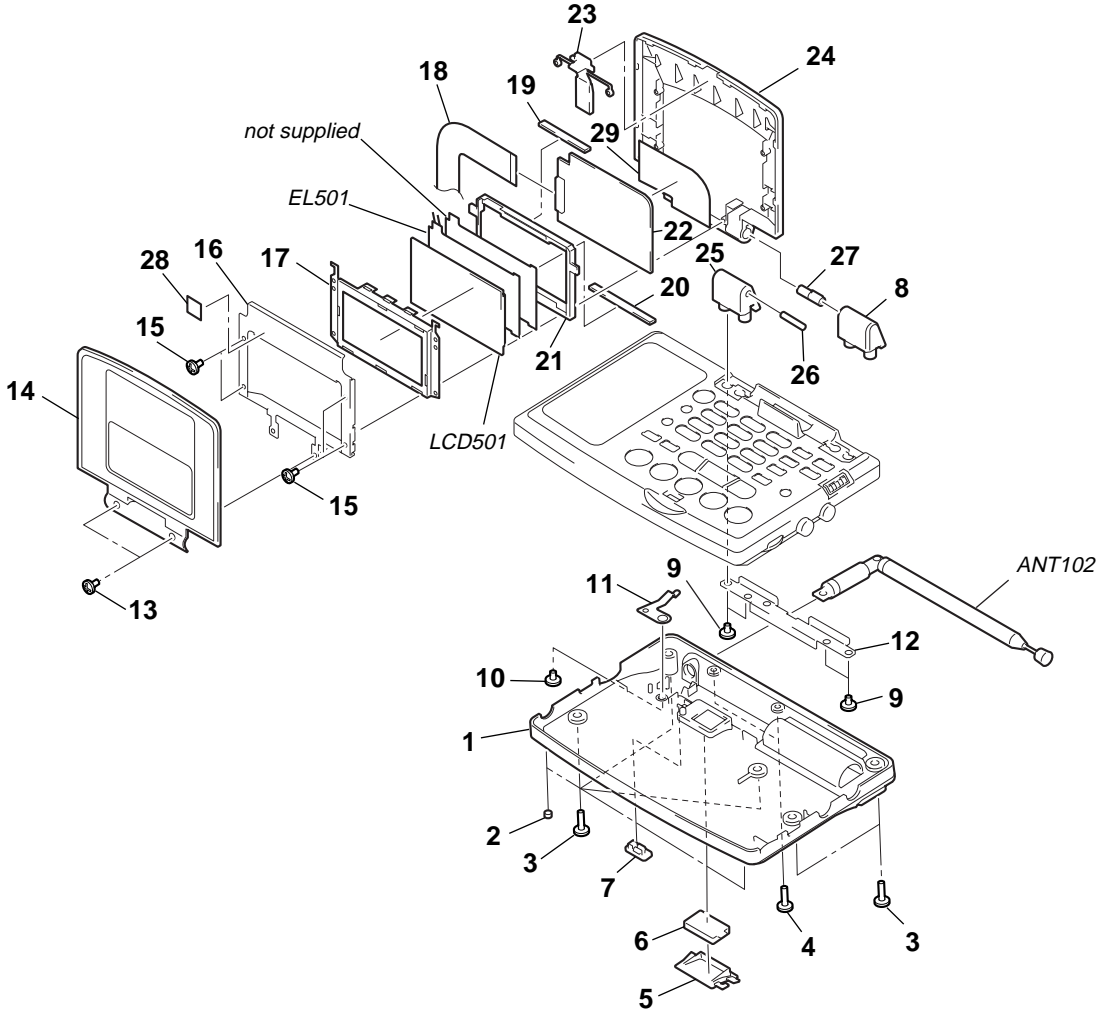

Ref. No.	Part No.	Description	Remark	Ref. No.	Part No.	Description	Remark
1	X-3377-539-1	CABINET (LOWER) ASSY		17	3-031-516-01	HOLDER (LCD)	
2	3-910-062-01	FOOT,RUBBER		18	1-672-548-11	FLEXIBLE BOARD	
3	3-371-765-11	SCREW(2X8), +BTP		19	1-694-492-11	CONDUCTIVE BOARD,CONNECTION(B)	
4	3-363-895-01	SCREW(M1.7)		20	1-694-491-11	CONDUCTIVE BOARD,CONNECTION(A)	
5	3-031-499-01	LID(ROM)		21	3-031-517-01	CASE(LCD)	
* 6	X-3377-112-1	ROM ASSY		* 22	A-3663-171-A	MICROCOMPUTER BOARD, COMPLETE	
7	3-031-500-01	STOPPER (ROM)		23	3-031-493-01	BUTTON (OPEN)	
8	3-031-509-01	ADAPTOR (SHAFT)		24	3-031-492-01	LID(FRONT)	
9	7-685-104-19	SCREW +P 2X6 TYPE2 NON-SLIT		25	3-031-510-01	ADAPTOR (PIN)	
10	3-719-381-01	SCREW (M2X4)		26	3-703-357-08	PIN(DIA. 1.6 SERISE)	
* 11	3-938-082-01	PLATE (ANT), CONTACT		27	X-3376-860-1	SHAFT ASSY	
* 12	3-031-513-01	REINFORCEMENT (A)		* 28	3-033-858-01	SPACER (FRAME)	
13	3-316-938-51	SCREW (B1.4X6), TAPPING		29	3-035-189-01	LEAF, COPPER (FPC)	
14	X-3376-587-1	LID(REAR) ASSY		ANT102	1-501-658-11	ANTENNA, TELESCOPIC (FM/SW)	
15	3-384-797-01	SCREW		EL501	1-803-372-11	ELEMENT, EL INDICATION (LCD BACK LIGHT)	
* 16	3-031-514-01	FRAME (LID)		LCD501	1-803-371-11	PANEL, LIQUID CRYSTAL DISPLAY	

6-2. CHASSIS SECTION

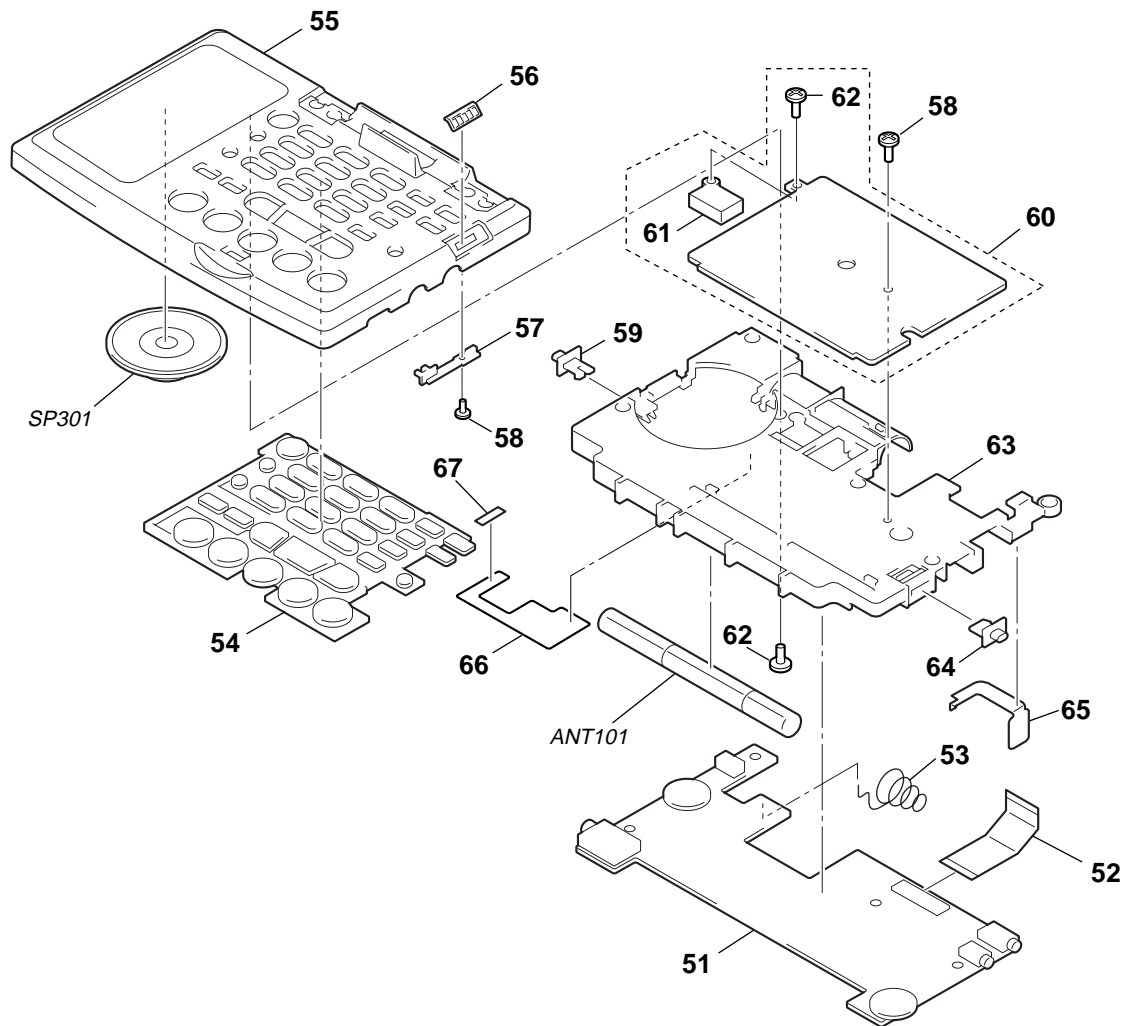

Ref. No.	Part No.	Description	Remark	Ref. No.	Part No.	Description	Remark
* 51	A-3683-027-A	MAIN BOARD, COMPLETE		* 61	A-3638-687-A	CONNECTOR ASSY	
52	1-672-549-11	FLEXIBLE BOARD		62	3-384-797-01	SCREW	
53	3-031-529-01	TERMINAL (-), BATTERY		63	3-031-494-01	CHASSIS	
54	3-031-491-01	BUTTON (10 KEY)		64	3-031-520-01	KNOB(TONE)	
55	X-3376-861-1	CABINET ASSY		65	3-031-518-01	TERMINAL (+), BATTERY	
56	3-031-511-01	KNOB(HOLD)		66	3-033-844-01	LEAF(3.64M), COPPER	
57	3-031-512-01	LEVER (HOLD)		67	3-355-482-01	SHEET (KT), ADHESIVE	
58	3-895-823-11	SCREW (B1.4X3), TAPPING		ANT101	1-501-657-22	FERRITE-ROD ANTENNA (MW/LW)	
59	3-031-519-01	KNOB(ATT)		SP301	1-505-165-11	SPEAKER (4cm)	
* 60	A-3683-026-A	KEYBOARD, COMPLETE					

6-3. ANTENNA CONTROLLER SECTION

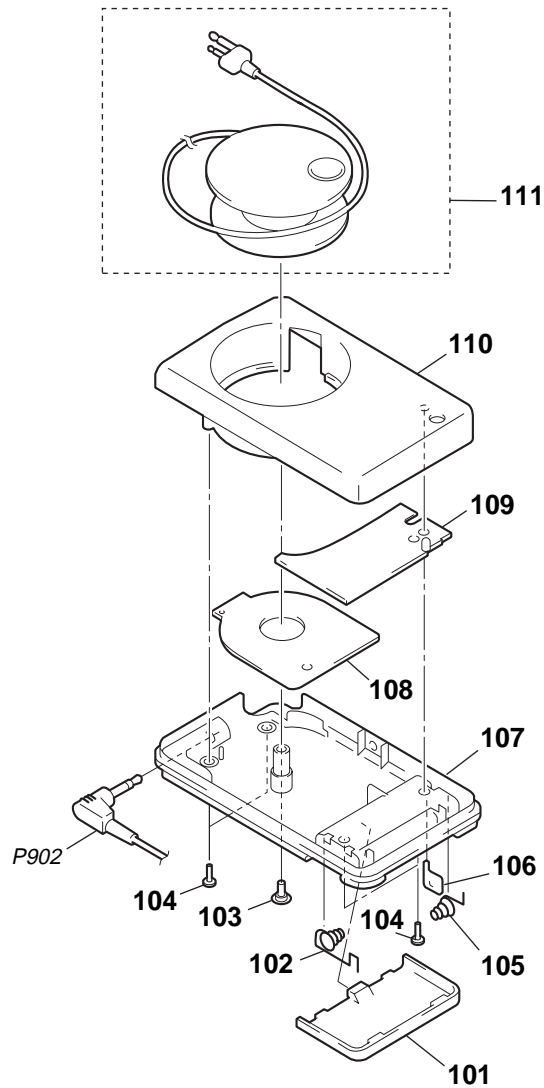

<u>Ref. No.</u>	<u>Part No.</u>	<u>Description</u>	<u>Remark</u>	<u>Ref. No.</u>	<u>Part No.</u>	<u>Description</u>	<u>Remark</u>
101	3-015-956-01	LID, BATTERY CASE		107	3-015-949-01	CABINET (REAR)	
102	3-907-747-01	SPRING (+/-B), BATTERY		* 108	1-666-723-11	REEL BOARD	
103	3-895-517-11	SCREW (2), TAPPING, STEP		* 109	A-3683-030-A	CONTROL BOARD, COMPLETE	
104	3-363-895-01	SCREW (M1.7)		110	3-030-407-01	CABINET (FRONT)	
105	3-907-745-01	SPRING (-), BATTERY		111	A-3638-504-A	REEL ASSY	
106	3-377-127-01	TERMINAL (+), BATTERY		P902	1-790-234-11	CODE (WITH PLUG)	

6-4. SW LOOP ANTENNA SECTION

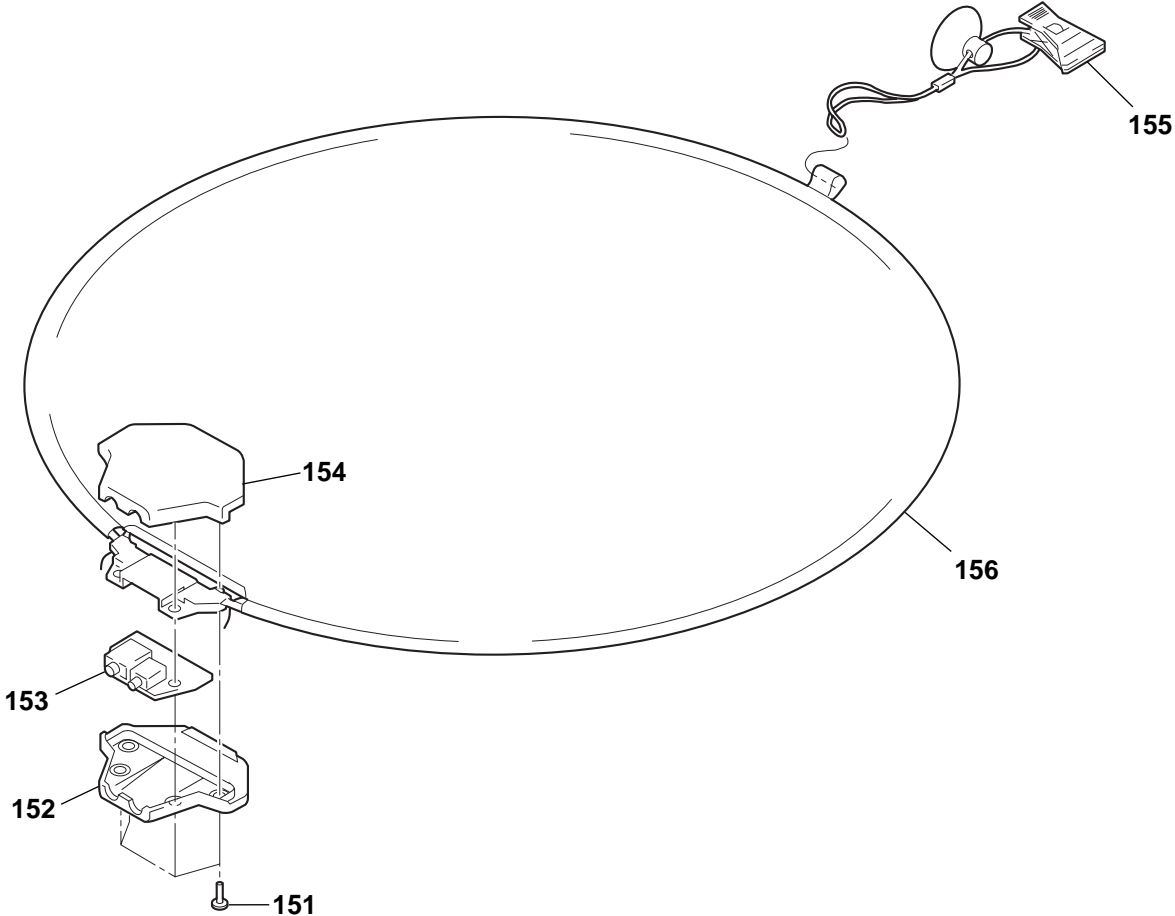

Ref. No.	Part No.	Description	Remark	Ref. No.	Part No.	Description	Remark
151	3-910-063-01	SCREW (1.7X10)		154	3-015-953-11	CASE (UPPER)	
152	3-015-954-01	CASE (LOWER)		155	3-018-979-01	CLIP (SUCKER)	
* 153	A-3683-029-A	ANTENNA BOARD, COMPLETE		156	X-3374-227-2	ANTENNA ASSY	

ANTENNA

CONTROL

**SECTION 7
ELECTRICAL PARTS LIST**

NOTE :

- Due to standardization, replacements in the parts list may be different from the parts specified in the diagrams or the components used on the set.
- -XX, -X mean standardized parts, so they may have some difference from the original one.
- RESISTORS
All resistors are in ohms
METAL : Metal-film resistor
METAL OXIDE :Metal oxide-film resistor
F : nonflammable
- Items marked “ * ”are not stocked since they are seldom required for routine service. Some delay should be anticipated when ordering these items.

- SEMICONDUCTORS
In each case, u : μ , for example :
uA.... : μ A.... , uPA.... : μ PA....
uPB.... : μ PB.... , uPC.... : μ PC....
uPD.... : μ PD....
- CAPACITORS
uF : μ F
- COILS
uH : μ H
- Abbreviation
AEP : AC adaptor is attached
7AEP : AC adaptor is not attached

The components identified by mark Δ or dotted line with mark Δ are critical for safety.
Replace only with part number specified.

Les composants identifiés par une marque Δ sont critiques pour la sécurité. Ne les remplacer que par une pièce portant le numéro spécifié.

When indicating parts by reference number, please include the board.

Ref. No.	Part No.	Description	Remark
*	A-3683-029-A	ANTENNA BOARD, COMPLETE *****	
		< CAPACITOR >	
C1	1-162-970-11	CERAMIC CHIP 0.01uF 10%	25V
C2	1-162-970-11	CERAMIC CHIP 0.01uF 10%	25V
C3	1-162-970-11	CERAMIC CHIP 0.01uF 10%	25V
C4	1-162-970-11	CERAMIC CHIP 0.01uF 10%	25V
C5	1-162-970-11	CERAMIC CHIP 0.01uF 10%	25V
C6	1-162-970-11	CERAMIC CHIP 0.01uF 10%	25V
C7	1-162-970-11	CERAMIC CHIP 0.01uF 10%	25V
C8	1-162-970-11	CERAMIC CHIP 0.01uF 10%	25V
C9	1-104-908-11	TANTAL. CHIP 47uF 20%	4V
C10	1-162-921-11	CERAMIC CHIP 33PF 5%	50V
C11	1-162-970-11	CERAMIC CHIP 0.01uF 10%	25V
		< DIODE >	
D1	8-719-421-40	DIODE MA77	
D2	8-719-421-40	DIODE MA77	
D5	8-713-101-57	DIODE 1T369-M20-T8A	
D6	8-713-101-57	DIODE 1T369-M20-T8A	
D7	8-713-101-57	DIODE 1T369-M20-T8A	
D8	8-713-101-57	DIODE 1T369-M20-T8A	
D9	8-719-988-61	DIODE 1SS355TE-17	
D10	8-719-988-61	DIODE 1SS355TE-17	
D11	8-719-988-61	DIODE 1SS355TE-17	
D12	8-719-988-61	DIODE 1SS355TE-17	
D13	8-719-988-61	DIODE 1SS355TE-17	
D14	8-719-800-76	DIODE 1SS226	
		< JACK >	
J1	1-569-215-11	JACK (FROM ANTENNA CONTROLLER)	
J2	1-573-996-11	JACK, SMALL (WATERPROOF) (FROM ANTENNA CONTROLLER)	
		< JUMPER RESISTOR >	
JC1	1-216-864-11	METAL CHIP 0 5%	1/16W
JC2	1-216-864-11	METAL CHIP 0 5%	1/16W
		< COIL >	
L1	1-408-412-00	INDUCTOR 18uH	
L2	1-410-658-31	INDUCTOR CHIP 220uH	

Ref. No.	Part No.	Description	Remark
L3	1-412-979-21	INDUCTOR 1uH	
		< TRANSISTOR >	
Q1	8-729-402-55	TRANSISTOR 2SB1218A-R	
Q2	8-766-002-46	TRANSISTOR SGM2016AP-T7	
		< RESISTOR >	
R1	1-216-813-11	METAL CHIP 220 5%	1/16W
R2	1-216-845-11	METAL CHIP 100K 5%	1/16W
R3	1-216-813-11	METAL CHIP 220 5%	1/16W
R4	1-216-845-11	METAL CHIP 100K 5%	1/16W
R5	1-216-845-11	METAL CHIP 100K 5%	1/16W
R6	1-216-845-11	METAL CHIP 100K 5%	1/16W
R7	1-216-837-11	METAL CHIP 22K 5%	1/16W
R8	1-216-805-11	METAL CHIP 47 5%	1/16W
R9	1-216-813-11	METAL CHIP 220 5%	1/16W
R10	1-216-809-11	METAL CHIP 100 5%	1/16W
		< TRANSFORMER >	
T1	1-426-357-11	TRANSFORMER, RF	

*	A-3683-030-A	CONTROL BOARD, COMPLETE *****	
		< CAPACITOR >	
C901	1-162-970-11	CERAMIC CHIP 0.01uF 10%	25V
C902	1-163-031-11	CERAMIC CHIP 0.01uF	50V
C903	1-162-970-11	CERAMIC CHIP 0.01uF 10%	25V
		< DIODE >	
D901	8-719-812-41	LED TLR124 (POWER)	
D902	8-719-800-76	DIODE 1SS226	
		< IC >	
IC901	8-759-568-84	IC S-80815ANNP-EDC-T2	
		< COIL >	
L901	1-410-658-31	INDUCTOR CHIP 220uH	
L902	1-410-658-31	INDUCTOR CHIP 220uH	

Ref. No.	Part No.	Description	Remark	Ref. No.	Part No.	Description	Remark
		< TRANSISTOR >					
Q901	8-729-402-32	TRANSISTOR 2SD1819A-R		R731	1-218-953-11	RES,CHIP 1K 5% 1/16W	
Q902	8-729-800-71	TRANSISTOR 2SB815B7-TB		R732	1-218-953-11	RES,CHIP 1K 5% 1/16W	
Q903	8-729-402-32	TRANSISTOR 2SD1819A-R		R733	1-218-953-11	RES,CHIP 1K 5% 1/16W	
		< RESISTOR >		R734	1-218-953-11	RES,CHIP 1K 5% 1/16W	
R901	1-216-845-11	METAL CHIP 100K 5% 1/16W		R735	1-218-953-11	RES,CHIP 1K 5% 1/16W	
R902	1-216-845-11	METAL CHIP 100K 5% 1/16W		R736	1-218-953-11	RES,CHIP 1K 5% 1/16W	
R903	1-216-833-11	METAL CHIP 10K 5% 1/16W		R737	1-218-953-11	RES,CHIP 1K 5% 1/16W	
R904	1-216-827-11	METAL CHIP 3.3K 5% 1/16W		R738	1-218-953-11	RES,CHIP 1K 5% 1/16W	
R905	1-216-845-11	METAL CHIP 100K 5% 1/16W				< SWITCH >	
R906	1-216-833-11	METAL CHIP 10K 5% 1/16W		S701	1-692-453-11	SWITCH, KEY BOARD (1)	
R907	1-216-833-11	METAL CHIP 10K 5% 1/16W		S702	1-692-453-11	SWITCH, KEY BOARD (4)	
R908	1-216-845-11	METAL CHIP 100K 5% 1/16W		S703	1-692-453-11	SWITCH, KEY BOARD (7)	
*****				S704	1-692-453-11	SWITCH, KEY BOARD (DIRECT)	
*	A-3683-026-A	KEY BOARD, COMPLETE		S705	1-692-453-11	SWITCH, KEY BOARD (FM/AM)	
		*****		S706	1-692-453-11	SWITCH, KEY BOARD (AM BAND LOCAL/ WORLD)	
	3-384-797-01	SCREW		S707	1-692-453-11	SWITCH, KEY BOARD (MY)	
		< CAPACITOR >		S708	1-692-453-11	SWITCH, KEY BOARD (LABEL EDIT)	
C701	1-162-970-11	CERAMIC CHIP 0.01uF 10% 25V		S709	1-692-453-11	SWITCH, KEY BOARD (2)	
		< CONNECTOR >		S710	1-692-453-11	SWITCH, KEY BOARD (5)	
* CN701	1-766-598-11	HOUSING, FPC CONNECTOR(ZIF)24P		S711	1-692-453-11	SWITCH, KEY BOARD (8)	
		< RESISTOR >		S712	1-692-453-11	SWITCH, KEY BOARD (0)	
R701	1-218-953-11	RES,CHIP 1K 5% 1/16W		S713	1-692-453-11	SWITCH, KEY BOARD (STANDBY MEMORY a)	
R702	1-218-953-11	RES,CHIP 1K 5% 1/16W		S714	1-692-453-11	SWITCH, KEY BOARD (BBC)	
R703	1-218-953-11	RES,CHIP 1K 5% 1/16W		S715	1-692-453-11	SWITCH, KEY BOARD (DW)	
R704	1-218-953-11	RES,CHIP 1K 5% 1/16W		S716	1-692-453-11	SWITCH, KEY BOARD (DST ERASE)	
R705	1-218-953-11	RES,CHIP 1K 5% 1/16W		S717	1-692-453-11	SWITCH, KEY BOARD (3)	
R706	1-218-953-11	RES,CHIP 1K 5% 1/16W		S718	1-692-453-11	SWITCH, KEY BOARD (6)	
R707	1-218-953-11	RES,CHIP 1K 5% 1/16W		S719	1-692-453-11	SWITCH, KEY BOARD (9)	
R708	1-218-953-11	RES,CHIP 1K 5% 1/16W		S720	1-692-453-11	SWITCH, KEY BOARD (DISPLAY EXE)	
R709	1-218-953-11	RES,CHIP 1K 5% 1/16W		S721	1-692-453-11	SWITCH, KEY BOARD (STANDBY MEMORY b)	
R710	1-218-953-11	RES,CHIP 1K 5% 1/16W		S722	1-692-453-11	SWITCH, KEY BOARD (VOA)	
R711	1-218-953-11	RES,CHIP 1K 5% 1/16W		S723	1-692-453-11	SWITCH, KEY BOARD (OTH)	
R712	1-218-953-11	RES,CHIP 1K 5% 1/16W		S724	1-692-453-11	SWITCH, KEY BOARD (TIME SET ENTER)	
R713	1-218-953-11	RES,CHIP 1K 5% 1/16W		S725	1-692-453-11	SWITCH, KEY BOARD (JOG/TUNE/SCAN → I +)	
R714	1-218-953-11	RES,CHIP 1K 5% 1/16W		S726	1-692-453-11	SWITCH, KEY BOARD (TIME DIF →)	
R715	1-218-953-11	RES,CHIP 1K 5% 1/16W		S727	1-692-453-11	SWITCH, KEY BOARD (TIME DIF ←)	
R716	1-218-953-11	RES,CHIP 1K 5% 1/16W		S728	1-692-453-11	SWITCH, KEY BOARD (JOG/TUNE/SCAN - ← •)	
R717	1-218-953-11	RES,CHIP 1K 5% 1/16W		S729	1-692-453-11	SWITCH, KEY BOARD (SYNC)	
R718	1-218-953-11	RES,CHIP 1K 5% 1/16W		S730	1-692-453-11	SWITCH, KEY BOARD (SSB)	
R719	1-218-953-11	RES,CHIP 1K 5% 1/16W		S731	1-692-453-11	SWITCH, KEY BOARD (POWER ON/OFF)	
R720	1-218-953-11	RES,CHIP 1K 5% 1/16W		S732	1-692-453-11	SWITCH, KEY BOARD (SLEEP)	
R721	1-218-953-11	RES,CHIP 1K 5% 1/16W		S733	1-572-922-11	SWITCH, SLIDE (HOLD →)	
R722	1-218-953-11	RES,CHIP 1K 5% 1/16W		S734	1-572-921-11	SWITCH, KEY BOARD (RESET)	
R723	1-218-953-11	RES,CHIP 1K 5% 1/16W		S735	1-692-453-11	SWITCH, KEY BOARD (LIGHT)	
R724	1-218-953-11	RES,CHIP 1K 5% 1/16W		*****			
R725	1-218-953-11	RES,CHIP 1K 5% 1/16W		*	A-3683-027-A	MAIN BOARD, COMPLETE	
R726	1-218-953-11	RES,CHIP 1K 5% 1/16W				*****	
R727	1-218-953-11	RES,CHIP 1K 5% 1/16W				< CAPACITOR >	
R728	1-218-953-11	RES,CHIP 1K 5% 1/16W		C101	1-165-176-11	CERAMIC CHIP 0.047uF 10% 16V	
R729	1-218-953-11	RES,CHIP 1K 5% 1/16W		C102	1-115-156-11	CERAMIC CHIP 1uF 10V	
R730	1-218-953-11	RES,CHIP 1K 5% 1/16W		C103	1-162-959-11	CERAMIC CHIP 330PF 5% 50V	
				C104	1-162-970-11	CERAMIC CHIP 0.01uF 10% 25V	

MAIN

Ref. No.	Part No.	Description			Remark	Ref. No.	Part No.	Description			Remark
C105	1-107-813-11	TANTAL. CHIP	10uF	20%	6.3V	C163	1-107-811-11	TANTAL. CHIP	47uF	20%	4V
C106	1-162-925-11	CERAMIC CHIP	68PF	5%	50V	C201	1-162-970-11	CERAMIC CHIP	0.01uF	10%	25V
C107	1-162-913-11	CERAMIC CHIP	8PF	0.5PF	50V	C202	1-162-979-11	CERAMIC CHIP	2700PF	5%	50V
C108	1-162-917-11	CERAMIC CHIP	15PF	5%	50V	C203	1-162-970-11	CERAMIC CHIP	0.01uF	10%	25V
C109	1-107-813-11	TANTAL. CHIP	10uF	20%	6.3V	C204	1-162-970-11	CERAMIC CHIP	0.01uF	10%	25V
C110	1-162-907-11	CERAMIC CHIP	2PF	0.25PF	50V	C205	1-115-156-11	CERAMIC CHIP	1uF		10V
C111	1-162-847-11	CERAMIC	0.047uF	10%	16V	C206	1-164-943-11	CERAMIC CHIP	0.01uF	10%	16V
C112	1-162-907-11	CERAMIC CHIP	2PF	0.25PF	50V	C207	1-115-156-11	CERAMIC CHIP	1uF		10V
C113	1-107-811-11	TANTAL. CHIP	47uF	20%	4V	C208	1-115-156-11	CERAMIC CHIP	1uF		10V
C114	1-162-970-11	CERAMIC CHIP	0.01uF	10%	25V	C209	1-162-970-11	CERAMIC CHIP	0.01uF	10%	25V
C115	1-162-970-11	CERAMIC CHIP	0.01uF	10%	25V	C210	1-115-156-11	CERAMIC CHIP	1uF		10V
C117	1-162-957-11	CERAMIC CHIP	220PF	5%	50V	C211	1-107-813-11	TANTAL. CHIP	10uF	20%	6.3V
C118	1-162-907-11	CERAMIC CHIP	2PF	0.25PF	50V	C212	1-162-908-11	CERAMIC CHIP	3PF	0.25PF	50V
C119	1-162-908-11	CERAMIC CHIP	3PF	0.25PF	50V	C213	1-164-357-11	CERAMIC CHIP	1000PF	5%	50V
C120	1-164-363-11	CERAMIC CHIP	560PF	5%	50V	C214	1-164-357-11	CERAMIC CHIP	1000PF	5%	50V
C121	1-162-925-11	CERAMIC CHIP	68PF	5%	50V	C215	1-162-916-11	CERAMIC CHIP	12PF	5%	50V
C122	1-115-156-11	CERAMIC CHIP	1uF		10V	C216	1-162-970-11	CERAMIC CHIP	0.01uF	10%	25V
C123	1-162-970-11	CERAMIC CHIP	0.01uF	10%	25V	C217	1-110-967-11	TANTAL. CHIP	100uF	20%	4V
C124	1-162-907-11	CERAMIC CHIP	2PF	0.25PF	50V	C218	1-162-910-11	CERAMIC CHIP	5PF	0.25PF	50V
C125	1-162-905-11	CERAMIC CHIP	1PF	0.25PF	50V	C219	1-162-904-11	CERAMIC CHIP	0.5PF	0.25PF	50V
C126	1-162-920-11	CERAMIC CHIP	27PF	5%	50V	C220	1-164-357-11	CERAMIC CHIP	1000PF	5%	50V
C127	1-107-813-11	TANTAL. CHIP	10uF	20%	6.3V	C221	1-164-357-11	CERAMIC CHIP	1000PF	5%	50V
C128	1-162-970-11	CERAMIC CHIP	0.01uF	10%	25V	C222	1-162-970-11	CERAMIC CHIP	0.01uF	10%	25V
C129	1-110-967-11	TANTAL. CHIP	100uF	20%	4V	C223	1-162-970-11	CERAMIC CHIP	0.01uF	10%	25V
C130	1-162-970-11	CERAMIC CHIP	0.01uF	10%	25V	C224	1-110-967-11	TANTAL. CHIP	100uF	20%	4V
C131	1-162-970-11	CERAMIC CHIP	0.01uF	10%	25V	C225	1-162-966-11	CERAMIC CHIP	0.0022uF	10%	50V
C132	1-107-813-11	TANTAL. CHIP	10uF	20%	6.3V	C226	1-162-970-11	CERAMIC CHIP	0.01uF	10%	25V
C133	1-162-970-11	CERAMIC CHIP	0.01uF	10%	25V	C227	1-162-970-11	CERAMIC CHIP	0.01uF	10%	25V
C134	1-162-914-11	CERAMIC CHIP	9PF	0.5PF	50V	C228	1-164-473-11	CERAMIC CHIP	820PF	5%	50V
C135	1-162-970-11	CERAMIC CHIP	0.01uF	10%	25V	C229	1-115-156-11	CERAMIC CHIP	1uF		10V
C136	1-162-970-11	CERAMIC CHIP	0.01uF	10%	25V	C230	1-162-964-11	CERAMIC CHIP	0.001uF	10%	50V
C137	1-162-970-11	CERAMIC CHIP	0.01uF	10%	25V	C232	1-164-937-11	CERAMIC CHIP	0.001uF	10%	16V
C138	1-162-970-11	CERAMIC CHIP	0.01uF	10%	25V	C233	1-162-964-11	CERAMIC CHIP	0.001uF	10%	50V
C139	1-107-811-11	TANTAL. CHIP	47uF	20%	4V	C301	1-115-156-11	CERAMIC CHIP	1uF		10V
C140	1-162-918-11	CERAMIC CHIP	18PF	5%	50V	C302	1-115-156-11	CERAMIC CHIP	1uF		10V
C141	1-164-376-11	CERAMIC CHIP	11PF	5%	50V	C303	1-164-156-11	CERAMIC CHIP	0.1uF		25V
C142	1-162-917-11	CERAMIC CHIP	15PF	5%	50V	C304	1-163-137-00	CERAMIC CHIP	680PF	5%	50V
C143	1-162-970-11	CERAMIC CHIP	0.01uF	10%	25V	C305	1-110-967-11	TANTAL. CHIP	100uF	20%	4V
C144	1-162-970-11	CERAMIC CHIP	0.01uF	10%	25V	C306	1-162-970-11	CERAMIC CHIP	0.01uF	10%	25V
C145	1-107-813-11	TANTAL. CHIP	10uF	20%	6.3V	C307	1-162-970-11	CERAMIC CHIP	0.01uF	10%	25V
C146	1-162-970-11	CERAMIC CHIP	0.01uF	10%	25V	C308	1-162-970-11	CERAMIC CHIP	0.01uF	10%	25V
C147	1-164-937-11	CERAMIC CHIP	0.001uF	10%	16V	C309	1-115-156-11	CERAMIC CHIP	1uF		10V
C148	1-162-970-11	CERAMIC CHIP	0.01uF	10%	25V	C310	1-162-970-11	CERAMIC CHIP	0.01uF	10%	25V
C149	1-162-964-11	CERAMIC CHIP	0.001uF	10%	50V	C311	1-164-677-11	CERAMIC CHIP	0.033uF	10%	16V
C150	1-162-970-11	CERAMIC CHIP	0.01uF	10%	25V	C312	1-115-156-11	CERAMIC CHIP	1uF		10V
C151	1-162-927-11	CERAMIC CHIP	100PF	5%	50V	C313	1-115-156-11	CERAMIC CHIP	1uF		10V
C152	1-164-937-11	CERAMIC CHIP	0.001uF	10%	16V	C314	1-162-970-11	CERAMIC CHIP	0.01uF	10%	25V
C153	1-115-156-11	CERAMIC CHIP	1uF		10V	C315	1-107-813-11	TANTAL. CHIP	10uF	20%	6.3V
C154	1-162-970-11	CERAMIC CHIP	0.01uF	10%	25V	C316	1-115-156-11	CERAMIC CHIP	1uF		10V
C155	1-164-943-11	CERAMIC CHIP	0.01uF	10%	16V	C317	1-115-156-11	CERAMIC CHIP	1uF		10V
C156	1-164-357-11	CERAMIC CHIP	1000PF	5%	50V	C318	1-115-156-11	CERAMIC CHIP	1uF		10V
C157	1-164-943-11	CERAMIC CHIP	0.01uF	10%	16V	C319	1-115-156-11	CERAMIC CHIP	1uF		10V
C158	1-162-970-11	CERAMIC CHIP	0.01uF	10%	25V	C320	1-164-245-11	CERAMIC CHIP	0.015uF	10%	25V
C159	1-107-813-11	TANTAL. CHIP	10uF	20%	6.3V	C321	1-164-245-11	CERAMIC CHIP	0.015uF	10%	25V
C160	1-164-357-11	CERAMIC CHIP	1000PF	5%	50V	C322	1-165-176-11	CERAMIC CHIP	0.047uF	10%	16V
C161	1-162-970-11	CERAMIC CHIP	0.01uF	10%	25V	C323	1-162-927-11	CERAMIC CHIP	100PF	5%	50V
C162	1-162-970-11	CERAMIC CHIP	0.01uF	10%	25V	C324	1-162-970-11	CERAMIC CHIP	0.01uF	10%	25V
						C325	1-165-128-91	CERAMIC CHIP	0.22uF	10%	16V

Ref. No.	Part No.	Description	Remark	Ref. No.	Part No.	Description	Remark
C326	1-115-156-11	CERAMIC CHIP	1uF	10V	C439	1-107-813-11	TANTAL. CHIP 10uF 20% 6.3V
C327	1-115-156-11	CERAMIC CHIP	1uF	10V	C440	1-164-005-11	CERAMIC CHIP 0.47uF 25V
C328	1-107-813-11	TANTAL. CHIP	10uF	20% 6.3V	C441	1-164-005-11	CERAMIC CHIP 0.47uF 25V
C329	1-107-811-11	TANTAL. CHIP	47uF	20% 4V	C442	1-164-850-11	CERAMIC CHIP 10PF 0.5PF 16V
C330	1-115-156-11	CERAMIC CHIP	1uF	10V	C443	1-164-005-11	CERAMIC CHIP 0.47uF 25V
C331	1-115-156-11	CERAMIC CHIP	1uF	10V	C444	1-164-943-11	CERAMIC CHIP 0.01uF 10% 16V
C332	1-165-176-11	CERAMIC CHIP	0.047uF	10% 16V	C445	1-107-813-11	TANTAL. CHIP 10uF 20% 6.3V
C333	1-162-927-11	CERAMIC CHIP	100PF	5% 50V	C446	1-125-618-11	DOUBLE LAYER 0.047F 0 5.5V
C334	1-107-813-11	TANTAL. CHIP	10uF	20% 6.3V	C447	1-115-156-11	CERAMIC CHIP 1uF 10V
C335	1-115-156-11	CERAMIC CHIP	1uF	10V	C448	1-115-156-11	CERAMIC CHIP 1uF 10V
C336	1-165-128-91	CERAMIC CHIP	0.22uF	10% 16V	C449	1-107-810-11	TANTAL. CHIP 33uF 20% 4V
C337	1-115-156-11	CERAMIC CHIP	1uF	10V	C450	1-162-970-11	CERAMIC CHIP 0.01uF 10% 25V
C338	1-107-811-11	TANTAL. CHIP	47uF	20% 4V	C451	1-107-811-11	TANTAL. CHIP 47uF 20% 4V
C339	1-128-391-11	ELECT CHIP	330uF	20% 6.3V	C452	1-113-619-11	CERAMIC CHIP 0.47uF 10V
C340	1-115-156-11	CERAMIC CHIP	1uF	10V	C453	1-107-812-11	TANTAL. CHIP 4.7uF 20% 6.3V
C341	1-110-967-11	TANTAL. CHIP	100uF	20% 4V	C454	1-115-156-11	CERAMIC CHIP 1uF 10V
C342	1-115-156-11	CERAMIC CHIP	1uF	10V	C455	1-115-156-11	CERAMIC CHIP 1uF 10V
C343	1-115-156-11	CERAMIC CHIP	1uF	10V	C456	1-164-156-11	CERAMIC CHIP 0.1uF 25V
C344	1-107-820-11	CERAMIC CHIP	0.1uF	16V	C457	1-164-156-11	CERAMIC CHIP 0.1uF 25V
C401	1-130-834-00	FILM	1uF	5% 63V	C458	1-164-156-11	CERAMIC CHIP 0.1uF 25V
C402	1-162-970-11	CERAMIC CHIP	0.01uF	10% 25V	C459	1-164-156-11	CERAMIC CHIP 0.1uF 25V
C403	1-162-970-11	CERAMIC CHIP	0.01uF	10% 25V	C460	1-115-156-11	CERAMIC CHIP 1uF 10V
C404	1-164-357-11	CERAMIC CHIP	1000PF	5% 50V	C461	1-107-811-11	TANTAL. CHIP 47uF 20% 4V
C405	1-162-970-11	CERAMIC CHIP	0.01uF	10% 25V			< FILTER >
C406	1-107-813-11	TANTAL. CHIP	10uF	20% 6.3V	CF201	1-760-199-11	FILTER, CERAMIC
C407	1-115-156-11	CERAMIC CHIP	1uF	10V	CF202	1-767-313-11	FILTER, CERAMIC
C408	1-162-970-11	CERAMIC CHIP	0.01uF	10% 25V	CF203	1-767-313-11	FILTER, CERAMIC
C409	1-162-927-11	CERAMIC CHIP	100PF	5% 50V	CF204	1-781-211-21	FILTER, CERAMIC (DISCRIMINATOR)
C410	1-162-927-11	CERAMIC CHIP	100PF	5% 50V			< CONNECTOR >
C411	1-107-820-11	CERAMIC CHIP	0.1uF	16V	CN401	1-785-566-21	HOUSING, FPC CONNECTOR(ZIF)35P
C412	1-115-156-11	CERAMIC CHIP	1uF	10V	* CN402	1-766-598-11	HOUSING, FPC CONNECTOR(ZIF)24P
C413	1-164-862-11	CERAMIC CHIP	33PF	5% 16V			< TRIMMER >
C414	1-164-848-11	CERAMIC CHIP	8PF	0.5PF 16V	CT101	1-141-327-11	CAP, CHIP TYPE TRIMMER 10PF (FM TRACKING)
C415	1-107-820-11	CERAMIC CHIP	0.1uF	16V	CT102	1-141-327-11	CAP, CHIP TYPE TRIMMER 10PF (FM TRACKING)
C416	1-162-970-11	CERAMIC CHIP	0.01uF	10% 25V	CT201	1-141-482-21	CAP, ADJ 10PF (AM 2ND LOCAL)
C417	1-162-970-11	CERAMIC CHIP	0.01uF	10% 25V	CT401	1-141-482-21	CAP, ADJ 10PF (FM100MHZ)
C418	1-162-970-11	CERAMIC CHIP	0.01uF	10% 25V			< DIODE >
C419	1-162-970-11	CERAMIC CHIP	0.01uF	10% 25V	D101	8-719-421-67	DIODE MA132WK
C420	1-162-970-11	CERAMIC CHIP	0.01uF	10% 25V	D102	8-719-002-81	DIODE 1T363
C421	1-162-970-11	CERAMIC CHIP	0.01uF	10% 25V	D103	8-719-421-40	DIODE MA77
C422	1-162-970-11	CERAMIC CHIP	0.01uF	10% 25V	D104	8-719-421-40	DIODE MA77
C423	1-162-970-11	CERAMIC CHIP	0.01uF	10% 25V	D105	8-719-421-40	DIODE MA77
C424	1-162-970-11	CERAMIC CHIP	0.01uF	10% 25V	D106	8-719-421-40	DIODE MA77
C425	1-164-937-11	CERAMIC CHIP	0.001uF	10% 16V	D107	8-719-800-76	DIODE 1SS226
C426	1-164-943-11	CERAMIC CHIP	0.01uF	10% 16V	D108	8-719-988-82	DIODE RB715F
C427	1-162-970-11	CERAMIC CHIP	0.01uF	10% 25V	D109	8-719-421-40	DIODE MA77
C428	1-164-874-11	CERAMIC CHIP	100PF	5% 16V	D110	8-719-002-81	DIODE 1T363
C429	1-162-970-11	CERAMIC CHIP	0.01uF	10% 25V	D111	8-719-002-81	DIODE 1T363
C430	1-110-967-11	TANTAL. CHIP	100uF	20% 4V	D112	8-719-046-91	DIODE MA2S111
C431	1-162-970-11	CERAMIC CHIP	0.01uF	10% 25V	D113	8-719-046-91	DIODE MA2S111
C432	1-110-967-11	TANTAL. CHIP	100uF	20% 4V	D114	8-719-046-91	DIODE MA2S111
C433	1-164-346-11	CERAMIC CHIP	1uF	16V	D201	8-719-060-48	DIODE RB751V-40TE-17
C434	1-164-346-11	CERAMIC CHIP	1uF	16V			
C435	1-164-850-11	CERAMIC CHIP	10PF	0.5PF 16V			
C436	1-164-850-11	CERAMIC CHIP	10PF	0.5PF 16V			
C437	1-107-820-11	CERAMIC CHIP	0.1uF	16V			
C438	1-162-970-11	CERAMIC CHIP	0.01uF	10% 25V			

MAIN

Ref. No.	Part No.	Description	Remark	Ref. No.	Part No.	Description	Remark
D202	8-719-002-81	DIODE 1T363		Q102	8-729-037-89	TRANSISTOR 2SC4627J-C(TX).SO	
D203	8-719-002-81	DIODE 1T363		Q103	8-729-123-86	TRANSISTOR 2SK238-K16	
D301	8-719-421-67	DIODE MA132WK		Q104	8-729-037-92	TRANSISTOR 2SD2216J-R(TX).SO	
D401	8-719-046-91	DIODE MA2S111		Q105	8-729-037-92	TRANSISTOR 2SD2216J-R(TX).SO	
D402	8-719-046-91	DIODE MA2S111		Q106	8-729-800-71	TRANSISTOR 2SB815B7-TB	
D403	8-719-420-87	DIODE MA8130		Q107	8-729-402-16	TRANSISTOR XN4608	
D404	8-719-060-48	DIODE RB751V-40TE-17		Q108	8-729-037-89	TRANSISTOR 2SC4627J-C(TX).SO	
D405	8-719-057-80	DIODE MA8160-M-TX		Q109	8-729-208-47	TRANSISTOR 2SK210-GR	
D406	8-719-988-82	DIODE RB715F		Q110	8-729-037-89	TRANSISTOR 2SC4627J-C(TX).SO	
D407	8-719-046-91	DIODE MA2S111		Q111	8-729-402-16	TRANSISTOR XN4608	
D408	8-719-975-40	DIODE RB411D		Q112	8-729-037-89	TRANSISTOR 2SC4627J-C(TX).SO	
		< IC >		Q113	8-729-123-86	TRANSISTOR 2SK238-K16	
IC101	8-759-461-80	IC S-81215SG-QK-T1		Q114	8-729-037-92	TRANSISTOR 2SD2216J-R(TX).SO	
IC201	8-752-064-32	IC CXA1376AM		Q115	8-729-037-92	TRANSISTOR 2SD2216J-R(TX).SO	
IC202	8-759-575-75	IC S-80822ANNP-EDK-T2		Q116	8-729-037-92	TRANSISTOR 2SD2216J-R(TX).SO	
IC301	8-759-804-98	IC LA3335M		Q117	8-729-116-64	TRANSISTOR 2SK508-K51	
IC302	8-752-058-42	IC CXA1622M		Q118	8-729-116-64	TRANSISTOR 2SK508-K51	
IC401	8-759-082-60	IC TC7S66FU		Q119	8-729-208-47	TRANSISTOR 2SK210-GR	
IC402	8-759-585-44	IC uPD17072GB-556-1A7		Q120	8-729-402-16	TRANSISTOR XN4608	
IC403	8-759-804-76	IC LA5002M		Q121	8-729-037-58	TRANSISTOR UN9110J-(TX).SO	
IC404	8-759-577-33	IC RN5RZ20BA-TR		Q122	8-729-037-58	TRANSISTOR UN9110J-(TX).SO	
IC405	8-759-524-23	IC TC74VHC238FT(EL)		Q123	8-729-037-71	TRANSISTOR UN9210J-(TX).SO	
		< JACK >		Q124	8-729-800-71	TRANSISTOR 2SB815B7-TB	
J101	1-573-178-11	JACK (AM EXT ANT)		Q125	8-729-037-58	TRANSISTOR UN9110J-(TX).SO	
J301	1-563-280-21	JACK (LINE OUT)		Q126	8-729-123-86	TRANSISTOR 2SK238-K16	
J302	1-573-177-11	JACK (⊘)		Q127	8-729-037-92	TRANSISTOR 2SD2216J-R(TX).SO	
J401	1-580-372-21	JACK,DC(POLARITY UNIFIED TYPE)(DC IN 3V)		Q128	8-729-037-92	TRANSISTOR 2SD2216J-R(TX).SO	
		< COIL >		Q129	8-729-800-71	TRANSISTOR 2SB815B7-TB	
L101	1-412-975-31	INDUCTOR 0.47uH		Q130	8-729-037-71	TRANSISTOR UN9210J-(TX).SO	
L102	1-412-987-31	INDUCTOR 4.7uH		Q131	8-729-037-92	TRANSISTOR 2SD2216J-R(TX).SO	
L103	1-412-978-21	INDUCTOR 0.82uH		Q132	8-729-037-71	TRANSISTOR UN9210J-(TX).SO	
L104	1-412-978-21	INDUCTOR 0.82uH		Q201	8-729-037-71	TRANSISTOR UN9210J-(TX).SO	
L105	1-412-993-11	INDUCTOR 15uH		Q202	8-729-037-58	TRANSISTOR UN9110J-(TX).SO	
L106	1-410-658-31	INDUCTOR CHIP 220uH		Q203	8-729-037-71	TRANSISTOR UN9210J-(TX).SO	
L107	1-412-985-11	INDUCTOR 3.3uH		Q204	8-729-037-89	TRANSISTOR 2SC4627J-C(TX).SO	
L108	1-410-658-31	INDUCTOR CHIP 220uH		Q205	8-729-037-58	TRANSISTOR UN9110J-(TX).SO	
L109	1-412-978-21	INDUCTOR 0.82uH		Q206	8-729-037-71	TRANSISTOR UN9210J-(TX).SO	
L110	1-412-983-11	INDUCTOR 2.2uH		Q207	8-729-037-71	TRANSISTOR UN9210J-(TX).SO	
L111	1-412-978-21	INDUCTOR 0.82uH		Q208	8-729-037-71	TRANSISTOR UN9210J-(TX).SO	
L112	1-412-973-11	INDUCTOR 0.33uH		Q209	8-729-037-71	TRANSISTOR UN9210J-(TX).SO	
L113	1-410-658-31	INDUCTOR CHIP 220uH		Q210	8-729-037-71	TRANSISTOR UN9210J-(TX).SO	
L114	1-412-979-21	INDUCTOR 1uH		Q301	8-729-037-61	TRANSISTOR UN9113J-(TX).SO	
L115	1-412-995-21	INDUCTOR 22uH		Q302	8-729-800-37	TRANSISTOR 2SD1048-X7	
L201	1-412-959-21	INDUCTOR CHIP 47uH		Q303	8-729-037-61	TRANSISTOR UN9113J-(TX).SO	
L202	1-412-989-11	INDUCTOR 6.8uH		Q304	8-729-037-71	TRANSISTOR UN9210J-(TX).SO	
L203	1-412-991-11	INDUCTOR 10uH		Q305	8-729-037-71	TRANSISTOR UN9210J-(TX).SO	
L204	1-412-975-31	INDUCTOR 0.47uH		Q306	8-729-037-71	TRANSISTOR UN9210J-(TX).SO	
L205	1-469-419-21	INDUCTOR		Q307	8-729-037-71	TRANSISTOR UN9210J-(TX).SO	
L401	1-412-997-11	INDUCTOR 33uH		Q308	8-729-037-92	TRANSISTOR 2SD2216J-R(TX).SO	
L402	1-412-963-11	INDUCTOR 100uH		Q309	8-729-037-92	TRANSISTOR 2SD2216J-R(TX).SO	
L403	1-412-963-11	INDUCTOR 100uH		Q310	8-729-037-71	TRANSISTOR UN9210J-(TX).SO	
L404	1-412-963-11	INDUCTOR 100uH		Q311	8-729-037-71	TRANSISTOR UN9210J-(TX).SO	
		< TRANSISTOR >		Q312	8-729-037-71	TRANSISTOR UN9210J-(TX).SO	
Q101	8-729-034-58	TRANSISTOR 2SC4555-6.7-TL		Q313	8-729-800-71	TRANSISTOR 2SB815B7-TB	
				Q314	8-729-037-71	TRANSISTOR UN9210J-(TX).SO	
				Q315	8-729-037-71	TRANSISTOR UN9210J-(TX).SO	
				Q316	8-729-037-71	TRANSISTOR UN9210J-(TX).SO	
				Q317	8-729-037-58	TRANSISTOR UN9110J-(TX).SO	

Ref. No.	Part No.	Description	Remark	Ref. No.	Part No.	Description	Remark
Q401	8-729-220-93	TRANSISTOR 2SK209-G		R111	1-218-937-11	RES,CHIP 47 5%	1/16W
Q402	8-729-220-93	TRANSISTOR 2SK209-G		R112	1-218-973-11	RES,CHIP 47K 5%	1/16W
Q403	8-729-037-92	TRANSISTOR 2SD2216J-R(TX).SO		R113	1-218-937-11	RES,CHIP 47 5%	1/16W
Q404	8-729-037-71	TRANSISTOR UN9210J-(TX).SO		R114	1-216-839-11	METAL CHIP 33K 5%	1/16W
Q405	8-729-037-71	TRANSISTOR UN9210J-(TX).SO		R115	1-218-937-11	RES,CHIP 47 5%	1/16W
Q406	8-729-037-92	TRANSISTOR 2SD2216J-R(TX).SO		R116	1-218-929-11	RES,CHIP 10 5%	1/16W
Q407	8-729-037-92	TRANSISTOR 2SD2216J-R(TX).SO		R117	1-216-805-11	METAL CHIP 47 5%	1/16W
Q408	8-729-037-92	TRANSISTOR 2SD2216J-R(TX).SO		R118	1-216-841-11	METAL CHIP 47K 5%	1/16W
Q409	8-729-037-92	TRANSISTOR 2SD2216J-R(TX).SO		R119	1-216-797-11	METAL CHIP 10 5%	1/16W
Q410	8-729-800-71	TRANSISTOR 2SB815B7-TB		R120	1-216-817-11	METAL CHIP 470 5%	1/16W
Q411	8-729-800-71	TRANSISTOR 2SB815B7-TB		R121	1-216-829-11	METAL CHIP 4.7K 5%	1/16W
Q412	8-729-037-71	TRANSISTOR UN9210J-(TX).SO		R122	1-216-845-11	METAL CHIP 100K 5%	1/16W
Q413	8-729-037-71	TRANSISTOR UN9210J-(TX).SO		R123	1-216-845-11	METAL CHIP 100K 5%	1/16W
Q414	8-729-037-61	TRANSISTOR UN9113J-(TX).SO		R124	1-216-821-11	METAL CHIP 1K 5%	1/16W
Q415	8-729-800-71	TRANSISTOR 2SB815B7-TB		R125	1-216-809-11	METAL CHIP 100 5%	1/16W
Q416	8-729-037-92	TRANSISTOR 2SD2216J-R(TX).SO		R126	1-216-839-11	METAL CHIP 33K 5%	1/16W
Q417	8-729-800-37	TRANSISTOR 2SD1048-X7		R127	1-216-853-11	METAL CHIP 470K 5%	1/16W
Q418	8-729-037-86	TRANSISTOR 2SB1462J-R(TX).SO		R128	1-216-825-11	METAL CHIP 2.2K 5%	1/16W
Q419	8-729-037-86	TRANSISTOR 2SB1462J-R(TX).SO		R129	1-216-853-11	METAL CHIP 470K 5%	1/16W
Q420	8-729-037-86	TRANSISTOR 2SB1462J-R(TX).SO		R130	1-216-813-11	METAL CHIP 220 5%	1/16W
Q421	8-729-037-86	TRANSISTOR 2SB1462J-R(TX).SO		R131	1-216-797-11	METAL CHIP 10 5%	1/16W
Q422	8-729-037-86	TRANSISTOR 2SB1462J-R(TX).SO		R132	1-216-845-11	METAL CHIP 100K 5%	1/16W
Q423	8-729-037-86	TRANSISTOR 2SB1462J-R(TX).SO		R133	1-216-825-11	METAL CHIP 2.2K 5%	1/16W
Q424	8-729-037-71	TRANSISTOR UN9210J-(TX).SO		R134	1-218-949-11	RES,CHIP 470 5%	1/16W
Q425	8-729-037-71	TRANSISTOR UN9210J-(TX).SO		R135	1-218-977-11	RES,CHIP 100K 5%	1/16W
Q426	8-729-037-71	TRANSISTOR UN9210J-(TX).SO		R136	1-216-841-11	METAL CHIP 47K 5%	1/16W
Q427	8-729-037-71	TRANSISTOR UN9210J-(TX).SO		R137	1-216-839-11	METAL CHIP 33K 5%	1/16W
Q428	8-729-037-71	TRANSISTOR UN9210J-(TX).SO		R138	1-216-825-11	METAL CHIP 2.2K 5%	1/16W
Q429	8-729-037-71	TRANSISTOR UN9210J-(TX).SO		R139	1-216-823-11	METAL CHIP 1.5K 5%	1/16W
Q430	8-729-037-71	TRANSISTOR UN9210J-(TX).SO		R140	1-216-823-11	METAL CHIP 1.5K 5%	1/16W
Q431	8-729-037-86	TRANSISTOR 2SB1462J-R(TX).SO		R141	1-216-797-11	METAL CHIP 10 5%	1/16W
Q432	8-729-037-86	TRANSISTOR 2SB1462J-R(TX).SO		R142	1-216-797-11	METAL CHIP 10 5%	1/16W
Q433	8-729-037-86	TRANSISTOR 2SB1462J-R(TX).SO		R143	1-216-805-11	METAL CHIP 47 5%	1/16W
Q434	8-729-037-86	TRANSISTOR 2SB1462J-R(TX).SO		R144	1-216-831-11	METAL CHIP 6.8K 5%	1/16W
Q435	8-729-037-86	TRANSISTOR 2SB1462J-R(TX).SO		R145	1-216-797-11	METAL CHIP 10 5%	1/16W
Q436	8-729-037-86	TRANSISTOR 2SB1462J-R(TX).SO		R146	1-216-813-11	METAL CHIP 220 5%	1/16W
Q437	8-729-037-71	TRANSISTOR UN9210J-(TX).SO		R147	1-216-805-11	METAL CHIP 47 5%	1/16W
Q438	8-729-037-71	TRANSISTOR UN9210J-(TX).SO		R148	1-216-829-11	METAL CHIP 4.7K 5%	1/16W
Q439	8-729-037-71	TRANSISTOR UN9210J-(TX).SO		R149	1-216-845-11	METAL CHIP 100K 5%	1/16W
Q440	8-729-037-71	TRANSISTOR UN9210J-(TX).SO		R150	1-216-845-11	METAL CHIP 100K 5%	1/16W
Q441	8-729-037-71	TRANSISTOR UN9210J-(TX).SO		R151	1-216-831-11	METAL CHIP 6.8K 5%	1/16W
Q442	8-729-037-71	TRANSISTOR UN9210J-(TX).SO		R152	1-216-833-11	METAL CHIP 10K 5%	1/16W
Q443	8-729-037-71	TRANSISTOR UN9210J-(TX).SO		R153	1-216-835-11	METAL CHIP 15K 5%	1/16W
Q444	8-729-037-92	TRANSISTOR 2SD2216J-R(TX).SO		R154	1-216-833-11	METAL CHIP 10K 5%	1/16W
Q445	8-729-037-71	TRANSISTOR UN9210J-(TX).SO		R155	1-216-837-11	METAL CHIP 22K 5%	1/16W
		< RESISTOR >		R156	1-218-953-11	RES,CHIP 1K 5%	1/16W
R101	1-216-841-11	METAL CHIP 47K 5%	1/16W	R157	1-218-977-11	RES,CHIP 100K 5%	1/16W
R102	1-216-847-11	METAL CHIP 150K 5%	1/16W	R158	1-218-977-11	RES,CHIP 100K 5%	1/16W
R103	1-216-853-11	METAL CHIP 470K 5%	1/16W	R159	1-216-845-11	METAL CHIP 100K 5%	1/16W
R104	1-216-845-11	METAL CHIP 100K 5%	1/16W	R160	1-216-797-11	METAL CHIP 10 5%	1/16W
R105	1-216-797-11	METAL CHIP 10 5%	1/16W	R161	1-216-845-11	METAL CHIP 100K 5%	1/16W
R106	1-216-833-11	METAL CHIP 10K 5%	1/16W	R162	1-216-833-11	METAL CHIP 10K 5%	1/16W
R107	1-216-833-11	METAL CHIP 10K 5%	1/16W	R163	1-218-965-11	RES,CHIP 10K 5%	1/16W
R108	1-216-833-11	METAL CHIP 10K 5%	1/16W	R164	1-216-845-11	METAL CHIP 100K 5%	1/16W
R109	1-216-845-11	METAL CHIP 100K 5%	1/16W	R165	1-216-845-11	METAL CHIP 100K 5%	1/16W
R110	1-216-845-11	METAL CHIP 100K 5%	1/16W	R166	1-216-833-11	METAL CHIP 10K 5%	1/16W
				R167	1-216-864-11	METAL CHIP 0 5%	1/16W
				R168	1-218-969-11	RES,CHIP 22K 5%	1/16W

MAIN

<u>Ref. No.</u>	<u>Part No.</u>	<u>Description</u>			<u>Remark</u>	<u>Ref. No.</u>	<u>Part No.</u>	<u>Description</u>			<u>Remark</u>
R201	1-216-826-11	METAL CHIP	2.7K	5%	1/16W	R404	1-216-833-11	METAL CHIP	10K	5%	1/16W
R202	1-216-851-11	METAL CHIP	330K	5%	1/16W	R405	1-216-833-11	METAL CHIP	10K	5%	1/16W
R203	1-216-837-11	METAL CHIP	22K	5%	1/16W	R406	1-216-833-11	METAL CHIP	10K	5%	1/16W
R204	1-216-838-11	METAL CHIP	27K	5%	1/16W	R407	1-216-797-11	METAL CHIP	10	5%	1/16W
R205	1-218-941-11	RES,CHIP	100	5%	1/16W	R408	1-218-929-11	RES,CHIP	10	5%	1/16W
R206	1-216-825-11	METAL CHIP	2.2K	5%	1/16W	R409	1-218-973-11	RES,CHIP	47K	5%	1/16W
R207	1-216-841-11	METAL CHIP	47K	5%	1/16W	R410	1-218-969-11	RES,CHIP	22K	5%	1/16W
R208	1-218-949-11	RES,CHIP	470	5%	1/16W	R411	1-218-969-11	RES,CHIP	22K	5%	1/16W
R209	1-216-845-11	METAL CHIP	100K	5%	1/16W	R412	1-218-969-11	RES,CHIP	22K	5%	1/16W
R210	1-216-813-11	METAL CHIP	220	5%	1/16W	R413	1-218-973-11	RES,CHIP	47K	5%	1/16W
R211	1-216-837-11	METAL CHIP	22K	5%	1/16W	R414	1-218-973-11	RES,CHIP	47K	5%	1/16W
R212	1-216-845-11	METAL CHIP	100K	5%	1/16W	R415	1-218-973-11	RES,CHIP	47K	5%	1/16W
R213	1-216-849-11	METAL CHIP	220K	5%	1/16W	R416	1-218-973-11	RES,CHIP	47K	5%	1/16W
R214	1-216-823-11	METAL CHIP	1.5K	5%	1/16W	R417	1-216-829-11	METAL CHIP	4.7K	5%	1/16W
R215	1-216-845-11	METAL CHIP	100K	5%	1/16W	R418	1-216-809-11	METAL CHIP	100	5%	1/16W
R216	1-216-825-11	METAL CHIP	2.2K	5%	1/16W	R419	1-218-948-11	RES,CHIP	100	5%	1/16W
R217	1-218-990-11	SHORT	0			R420	1-218-965-11	RES,CHIP	10K	5%	1/16W
R218	1-218-983-11	RES,CHIP	330K	5%	1/16W	R421	1-216-825-11	METAL CHIP	2.2K	5%	1/16W
R219	1-218-977-11	RES,CHIP	100K	5%	1/16W	R422	1-216-825-11	METAL CHIP	2.2K	5%	1/16W
R220	1-216-833-11	METAL CHIP	10K	5%	1/16W	R423	1-216-825-11	METAL CHIP	2.2K	5%	1/16W
R221	1-216-825-11	METAL CHIP	2.2K	5%	1/16W	R424	1-216-825-11	METAL CHIP	2.2K	5%	1/16W
R222	1-216-797-11	METAL CHIP	10	5%	1/16W	R425	1-216-825-11	METAL CHIP	2.2K	5%	1/16W
R223	1-216-864-11	METAL CHIP	0	5%	1/16W	R426	1-216-825-11	METAL CHIP	2.2K	5%	1/16W
R224	1-216-864-11	METAL CHIP	0	5%	1/16W	R427	1-216-825-11	METAL CHIP	2.2K	5%	1/16W
R301	1-216-797-11	METAL CHIP	10	5%	1/16W	R428	1-216-825-11	METAL CHIP	2.2K	5%	1/16W
R302	1-216-840-11	METAL CHIP	39K	5%	1/16W	R429	1-216-825-11	METAL CHIP	2.2K	5%	1/16W
R303	1-216-833-11	METAL CHIP	10K	5%	1/16W	R430	1-218-973-11	RES,CHIP	47K	5%	1/16W
R304	1-216-833-11	METAL CHIP	10K	5%	1/16W	R431	1-218-973-11	RES,CHIP	47K	5%	1/16W
R305	1-216-833-11	METAL CHIP	10K	5%	1/16W	R432	1-216-841-11	METAL CHIP	47K	5%	1/16W
R306	1-216-833-11	METAL CHIP	10K	5%	1/16W	R433	1-216-825-11	METAL CHIP	2.2K	5%	1/16W
R307	1-216-797-11	METAL CHIP	10	5%	1/16W	R434	1-218-957-11	RES,CHIP	2.2K	5%	1/16W
R308	1-216-833-11	METAL CHIP	10K	5%	1/16W	R435	1-218-957-11	RES,CHIP	2.2K	5%	1/16W
R309	1-216-833-11	METAL CHIP	10K	5%	1/16W	R436	1-216-825-11	METAL CHIP	2.2K	5%	1/16W
R310	1-216-851-11	METAL CHIP	330K	5%	1/16W	R437	1-218-957-11	RES,CHIP	2.2K	5%	1/16W
R311	1-216-821-11	METAL CHIP	1K	5%	1/16W	R438	1-218-957-11	RES,CHIP	2.2K	5%	1/16W
R312	1-216-851-11	METAL CHIP	330K	5%	1/16W	R439	1-218-973-11	RES,CHIP	47K	5%	1/16W
R313	1-216-821-11	METAL CHIP	1K	5%	1/16W	R440	1-218-990-11	SHORT	0		
R314	1-216-805-11	METAL CHIP	47	5%	1/16W	R441	1-218-953-11	RES,CHIP	1K	5%	1/16W
R315	1-216-805-11	METAL CHIP	47	5%	1/16W	R442	1-218-977-11	RES,CHIP	100K	5%	1/16W
R316	1-218-937-11	RES,CHIP	47	5%	1/16W	R443	1-218-977-11	RES,CHIP	100K	5%	1/16W
R317	1-218-955-11	RES,CHIP	1.5K	5%	1/16W	R444	1-218-977-11	RES,CHIP	100K	5%	1/16W
R318	1-216-809-11	METAL CHIP	100	5%	1/16W	R445	1-218-949-11	RES,CHIP	470	5%	1/16W
R319	1-216-827-11	METAL CHIP	3.3K	5%	1/16W	R446	1-218-977-11	RES,CHIP	100K	5%	1/16W
R320	1-216-833-11	METAL CHIP	10K	5%	1/16W	R447	1-218-975-11	RES,CHIP	68K	5%	1/16W
R321	1-216-833-11	METAL CHIP	10K	5%	1/16W	R448	1-218-977-11	RES,CHIP	100K	5%	1/16W
R322	1-216-864-11	METAL CHIP	0	5%	1/16W	R449	1-216-821-11	METAL CHIP	1K	5%	1/16W
R323	1-216-821-11	METAL CHIP	1K	5%	1/16W	R450	1-216-821-11	METAL CHIP	1K	5%	1/16W
R324	1-216-833-11	METAL CHIP	10K	5%	1/16W	R451	1-216-809-11	METAL CHIP	100	5%	1/16W
R325	1-218-937-11	RES,CHIP	47	5%	1/16W	R452	1-216-821-11	METAL CHIP	1K	5%	1/16W
R326	1-216-829-11	METAL CHIP	4.7K	5%	1/16W	R453	1-216-857-11	METAL CHIP	1M	5%	1/16W
R327	1-216-809-11	METAL CHIP	100	5%	1/16W	R454	1-216-857-11	METAL CHIP	1M	5%	1/16W
R328	1-218-945-11	RES,CHIP	220	5%	1/16W	R455	1-216-821-11	METAL CHIP	1K	5%	1/16W
R329	1-216-833-11	METAL CHIP	10K	5%	1/16W	R456	1-216-789-11	METAL CHIP	2.2	5%	1/16W
R330	1-218-965-11	RES,CHIP	10K	5%	1/16W	R457	1-216-825-11	METAL CHIP	2.2K	5%	1/16W
R401	1-216-829-11	METAL CHIP	4.7K	5%	1/16W	R458	1-216-799-11	METAL CHIP	15	5%	1/16W
R402	1-216-835-11	METAL CHIP	15K	5%	1/16W	R459	1-216-855-11	METAL CHIP	680K	5%	1/16W
R403	1-216-797-11	METAL CHIP	10	5%	1/16W	R460	1-216-855-11	METAL CHIP	680K	5%	1/16W
						R461	1-216-853-11	METAL CHIP	470K	5%	1/16W

Ref. No.	Part No.	Description	Remark	Ref. No.	Part No.	Description	Remark
R462	1-216-851-11	METAL CHIP	330K 5% 1/16W	RV410	1-241-482-11	RES, ADJ, CERMET	220K(16mb)
R463	1-216-851-11	METAL CHIP	330K 5% 1/16W	RV411	1-241-482-11	RES, ADJ, CERMET	220K(41mb)
R464	1-216-850-11	METAL CHIP	270K 5% 1/16W	RV412	1-241-482-11	RES, ADJ, CERMET	220K(13mb)
R465	1-216-845-11	METAL CHIP	100K 5% 1/16W			< SWITCH >	
R466	1-216-841-11	METAL CHIP	47K 5% 1/16W	S101	1-771-246-21	SWITCH, SLIDE (ATT)	
R467	1-216-829-11	METAL CHIP	4.7K 5% 1/16W	S301	1-572-922-11	SWITCH, SLIDE (TONE)	
R468	1-216-843-11	METAL CHIP	68K 5% 1/16W			< TRANSFORMER >	
R469	1-216-839-11	METAL CHIP	33K 5% 1/16W	T101	1-423-983-41	TRANSFORMER, HIGH FREQUENCY	
R470	1-216-845-11	METAL CHIP	100K 5% 1/16W	T102	1-403-629-41	COIL (WITH CORE) (OSC)	
R471	1-216-849-11	METAL CHIP	220K 5% 1/16W	T103	1-423-981-11	TRANSFORMER, HIGH FREQUENCY	
R472	1-216-849-11	METAL CHIP	220K 5% 1/16W	T104	1-403-633-41	TRANSFORMER, IF (AM 1ST IF)	
R473	1-216-843-11	METAL CHIP	68K 5% 1/16W	T105	1-403-604-41	TRANSFORMER, IF (AM 1ST IF)	
R474	1-216-847-11	METAL CHIP	150K 5% 1/16W	T106	1-411-446-21	COIL (FM ANT) (FM TRACKING)	
R475	1-216-864-11	METAL CHIP	0 5% 1/16W	T107	1-411-445-21	COIL (FM RF) (FM TRACKING)	
R476	1-216-864-11	METAL CHIP	0 5% 1/16W	T201	1-403-638-41	COIL (WITH CORE) (OSC)	
R477	1-216-844-11	METAL CHIP	82K 5% 1/16W			(FM FREQUENCY COVERAGE)	
R478	1-216-845-11	METAL CHIP	100K 5% 1/16W	T401	1-433-539-21	TRANSFORMER, EL	
R479	1-216-850-11	METAL CHIP	270K 5% 1/16W	T402	1-449-021-21	COIL, DC/DC CONVERTER	
R480	1-216-851-11	METAL CHIP	330K 5% 1/16W	T403	1-450-531-21	TRANSFORMER, DC-DC CONVERTER	
R481	1-216-853-11	METAL CHIP	470K 5% 1/16W			< VIBRATOR >	
R482	1-216-855-11	METAL CHIP	680K 5% 1/16W	X201	1-760-200-11	VIBRATOR, CERAMIC (3.640MHz)	
R483	1-216-797-11	METAL CHIP	10 5% 1/16W	X202	1-760-197-11	VIBRATOR, CRYSTAL (55.390MHz)	
R484	1-216-845-11	METAL CHIP	100K 5% 1/16W	X401	1-579-744-21	VIBRATOR, CRYSTAL (75kHz)	
R485	1-216-833-11	METAL CHIP	10K 5% 1/16W			< FILTER >	
R486	1-216-833-11	METAL CHIP	10K 5% 1/16W	XF101	1-760-198-11	FILTER, CRYSTAL	
R487	1-216-833-11	METAL CHIP	10K 5% 1/16W	*****			
R488	1-216-833-11	METAL CHIP	10K 5% 1/16W	*	A-3663-171-A	MICROCOMPUTER BOARD, COMPLETE	
R489	1-218-965-11	RES,CHIP	10K 5% 1/16W	*****			
R490	1-216-833-11	METAL CHIP	10K 5% 1/16W	Caution :			
R491	1-218-965-11	RES,CHIP	10K 5% 1/16W	When replacing the microcomputer board, remove IC503 from the older			
R492	1-218-965-11	RES,CHIP	10K 5% 1/16W	circuit board and add it to the new circuit board. This allows continued use			
R493	1-218-965-11	RES,CHIP	10K 5% 1/16W	of the user's preset memory.			
R494	1-218-953-11	RES,CHIP	1K 5% 1/16W		1-672-548-11	FLEXIBLE BOARD	
R495	1-218-965-11	RES,CHIP	10K 5% 1/16W		1-694-491-11	CONDUCTIVE BOARD,CONNECTION(A)	
R496	1-218-965-11	RES,CHIP	10K 5% 1/16W		1-694-492-11	CONDUCTIVE BOARD,CONNECTION(B)	
R497	1-218-965-11	RES,CHIP	10K 5% 1/16W		3-031-516-01	HOLDER (LCD)	
R498	1-218-965-11	RES,CHIP	10K 5% 1/16W		3-031-517-01	CASE (LCD)	
R499	1-216-849-11	METAL CHIP	220K 5% 1/16W			< CAPACITOR >	
		< VARIABLE RESISTOR >		C501	1-115-156-11	CERAMIC CHIP 1uF	10V
RV101	1-237-870-11	RES, VAR, CARBON	20K (ATT)	C502	1-162-927-11	CERAMIC CHIP 100PF	5% 50V
RV201	1-241-481-11	RES, ADJ, CERMET	100K (SSB ZERO BEAT)	C503	1-162-927-11	CERAMIC CHIP 100PF	5% 50V
RV202	1-241-481-11	RES, ADJ, CERMET	100K(SD)	C504	1-162-927-11	CERAMIC CHIP 100PF	5% 50V
RV203	1-241-481-11	RES, ADJ, CERMET	100K (AM 2ND LOCAL)	C505	1-162-927-11	CERAMIC CHIP 100PF	5% 50V
RV301	1-241-479-11	RES, ADJ, CERMET	22K (FM STEREO)	C506	1-162-927-11	CERAMIC CHIP 100PF	5% 50V
RV302	1-241-849-11	RES, VAR, CARBON	50K (VOL ▲)	C507	1-162-927-11	CERAMIC CHIP 100PF	5% 50V
RV401	1-241-481-11	RES, ADJ, CERMET	100K(120mb)	C508	1-162-927-11	CERAMIC CHIP 100PF	5% 50V
RV402	1-241-481-11	RES, ADJ, CERMET	100K(31mb)	C509	1-162-927-11	CERAMIC CHIP 100PF	5% 50V
RV403	1-241-482-11	RES, ADJ, CERMET	220K(90mb)	C510	1-162-970-11	CERAMIC CHIP 0.01uF	10% 25V
RV404	1-241-481-11	RES, ADJ, CERMET	100K(25mb)	C511	1-162-970-11	CERAMIC CHIP 0.01uF	10% 25V
RV405	1-241-482-11	RES, ADJ, CERMET	220K(75mb)	C512	1-162-970-11	CERAMIC CHIP 0.01uF	10% 25V
RV406	1-241-481-11	RES, ADJ, CERMET	100K(22mb)	C513	1-162-970-11	CERAMIC CHIP 0.01uF	10% 25V
RV407	1-241-482-11	RES, ADJ, CERMET	220K(60mb)	C514	1-162-970-11	CERAMIC CHIP 0.01uF	10% 25V
RV408	1-241-482-11	RES, ADJ, CERMET	220K(19mb)				
RV409	1-241-482-11	RES, ADJ, CERMET	220K(49mb)				

MICROCOMPUTER

Ref. No.	Part No.	Description	Remark	Ref. No.	Part No.	Description	Remark
C515	1-162-970-11	CERAMIC CHIP	0.01uF 10% 25V			< CONNECTOR >	
C516	1-162-970-11	CERAMIC CHIP	0.01uF 10% 25V	CN502	1-785-566-21	HOUSING, FPC CONNECTOR(ZIF)35P	
C517	1-162-927-11	CERAMIC CHIP	100PF 5% 50V			< TRIMMER >	
C518	1-162-927-11	CERAMIC CHIP	100PF 5% 50V				
C519	1-162-970-11	CERAMIC CHIP	0.01uF 10% 25V	CT501	1-141-327-11	CAP, CHIP TYPE TRIMMER 10PF (4MHz SYSTEM CLOCK)	
C520	1-162-970-11	CERAMIC CHIP	0.01uF 10% 25V			< DIODE >	
C521	1-162-927-11	CERAMIC CHIP	100PF 5% 50V	D501	8-719-046-91	DIODE MA2S111	
C522	1-162-927-11	CERAMIC CHIP	100PF 5% 50V	D502	8-719-060-48	DIODE RB751V-40TE-17	
C523	1-162-927-11	CERAMIC CHIP	100PF 5% 50V	D503	8-719-060-48	DIODE RB751V-40TE-17	
C524	1-115-156-11	CERAMIC CHIP	1uF 10V	D504	8-719-060-48	DIODE RB751V-40TE-17	
C525	1-162-964-11	CERAMIC CHIP	0.001uF 10% 50V	D505	8-719-060-48	DIODE RB751V-40TE-17	
C526	1-162-964-11	CERAMIC CHIP	0.001uF 10% 50V	D506	8-719-420-87	DIODE MA8130	
C527	1-162-915-11	CERAMIC CHIP	10PF 0.5PF 50V	D507	8-719-060-48	DIODE RB751V-40TE-17	
C529	1-162-919-11	CERAMIC CHIP	22PF 5% 50V			< EL LUMINOUS ELEMENT >	
C530	1-162-919-11	CERAMIC CHIP	22PF 5% 50V	EL501	1-803-372-11	ELEMENT, EL INDICATION (LCD BACK LIGHT)	
C531	1-162-970-11	CERAMIC CHIP	0.01uF 10% 25V			< IC >	
C532	1-162-920-11	CERAMIC CHIP	27PF 5% 50V	IC501	8-759-585-45	IC uPD753017AGK-717-BE9	
C533	1-162-920-11	CERAMIC CHIP	27PF 5% 50V	IC502	8-759-585-46	IC uPD753012AGK-781-BE9	
C534	1-162-970-11	CERAMIC CHIP	0.01uF 10% 25V	IC503	8-759-465-76	IC AK93C85AM-E2	
C535	1-162-970-11	CERAMIC CHIP	0.01uF 10% 25V	IC504	8-759-082-57	IC TC7W04FU	
C536	1-162-970-11	CERAMIC CHIP	0.01uF 10% 25V	IC505	8-759-278-04	IC S-81220SG-QS-T2	
C537	1-162-970-11	CERAMIC CHIP	0.01uF 10% 25V	IC506	8-759-578-28	IC S-80819ANNP-EDG-T2	
C538	1-162-964-11	CERAMIC CHIP	0.001uF 10% 50V	IC507	8-759-575-75	IC S-80822ANNP-EDK-T2	
C539	1-162-927-11	CERAMIC CHIP	100PF 5% 50V	IC508	8-759-577-41	IC S-80817ANNP-EDE-T2	
C540	1-162-964-11	CERAMIC CHIP	0.001uF 10% 50V			< COIL >	
C541	1-162-970-11	CERAMIC CHIP	0.01uF 10% 25V	L501	1-412-995-21	INDUCTOR 22uH	
C542	1-162-970-11	CERAMIC CHIP	0.01uF 10% 25V	L502	1-412-995-21	INDUCTOR 22uH	
C543	1-162-970-11	CERAMIC CHIP	0.01uF 10% 25V			< LIQUID CRYSTAL DISPLAY >	
C544	1-162-927-11	CERAMIC CHIP	100PF 5% 50V	LCD501	1-803-371-11	PANEL, LIQUID CRYSTAL DISPLAY	
C545	1-162-927-11	CERAMIC CHIP	100PF 5% 50V			< TRANSISTOR >	
C546	1-162-970-11	CERAMIC CHIP	0.01uF 10% 25V	Q501	8-729-037-71	TRANSISTOR UN9210J-(TX).SO	
C547	1-162-927-11	CERAMIC CHIP	100PF 5% 50V	Q502	8-729-037-86	TRANSISTOR 2SB1462J-R(TX).SO	
C548	1-115-156-11	CERAMIC CHIP	1uF 10V	Q503	8-729-037-86	TRANSISTOR 2SB1462J-R(TX).SO	
C549	1-162-970-11	CERAMIC CHIP	0.01uF 10% 25V	Q504	8-729-037-71	TRANSISTOR UN9210J-(TX).SO	
C550	1-162-970-11	CERAMIC CHIP	0.01uF 10% 25V	Q505	8-729-037-71	TRANSISTOR UN9210J-(TX).SO	
C551	1-162-970-11	CERAMIC CHIP	0.01uF 10% 25V	Q506	8-729-037-71	TRANSISTOR UN9210J-(TX).SO	
C552	1-162-970-11	CERAMIC CHIP	0.01uF 10% 25V	Q507	8-729-037-71	TRANSISTOR UN9210J-(TX).SO	
C553	1-162-970-11	CERAMIC CHIP	0.01uF 10% 25V	Q508	8-729-037-71	TRANSISTOR UN9210J-(TX).SO	
C554	1-162-927-11	CERAMIC CHIP	100PF 5% 50V			< RESISTOR >	
C555	1-162-927-11	CERAMIC CHIP	100PF 5% 50V	R501	1-216-825-11	METAL CHIP 2.2K 5% 1/16W	
C556	1-162-927-11	CERAMIC CHIP	100PF 5% 50V	R502	1-216-825-11	METAL CHIP 2.2K 5% 1/16W	
C557	1-162-964-11	CERAMIC CHIP	0.001uF 10% 50V	R503	1-216-825-11	METAL CHIP 2.2K 5% 1/16W	
C558	1-115-156-11	CERAMIC CHIP	1uF 10V	R504	1-216-825-11	METAL CHIP 2.2K 5% 1/16W	
C559	1-162-970-11	CERAMIC CHIP	0.01uF 10% 25V	R505	1-216-825-11	METAL CHIP 2.2K 5% 1/16W	
C560	1-162-904-11	CERAMIC CHIP	0.5PF 0.25PF 50V	R506	1-216-825-11	METAL CHIP 2.2K 5% 1/16W	
C561	1-162-970-11	CERAMIC CHIP	0.01uF 10% 25V	R507	1-216-825-11	METAL CHIP 2.2K 5% 1/16W	
C562	1-115-156-11	CERAMIC CHIP	1uF 10V	R508	1-216-825-11	METAL CHIP 2.2K 5% 1/16W	
C563	1-162-964-11	CERAMIC CHIP	0.001uF 10% 50V	R509	1-216-825-11	METAL CHIP 2.2K 5% 1/16W	
C564	1-115-156-11	CERAMIC CHIP	1uF 10V				
C565	1-162-964-11	CERAMIC CHIP	0.001uF 10% 50V				
C566	1-162-964-11	CERAMIC CHIP	0.001uF 10% 50V				
C567	1-162-964-11	CERAMIC CHIP	0.001uF 10% 50V				
C568	1-162-970-11	CERAMIC CHIP	0.01uF 10% 25V				
C569	1-162-970-11	CERAMIC CHIP	0.01uF 10% 25V				
C570	1-162-970-11	CERAMIC CHIP	0.01uF 10% 25V				

MICROCOMPUTER

REEL

ROM

Ref. No.	Part No.	Description	Remark	Ref. No.	Part No.	Description	Remark
R510	1-216-825-11	METAL CHIP	2.2K 5% 1/16W	R566	1-216-825-11	METAL CHIP	2.2K 5% 1/16W
R511	1-216-825-11	METAL CHIP	2.2K 5% 1/16W	R567	1-216-825-11	METAL CHIP	2.2K 5% 1/16W
R512	1-216-825-11	METAL CHIP	2.2K 5% 1/16W	R568	1-216-797-11	METAL CHIP	10 5% 1/16W
R513	1-216-825-11	METAL CHIP	2.2K 5% 1/16W	R569	1-216-857-11	METAL CHIP	1M 5% 1/16W
R514	1-216-845-11	METAL CHIP	100K 5% 1/16W	R570	1-216-825-11	METAL CHIP	2.2K 5% 1/16W
R515	1-216-845-11	METAL CHIP	100K 5% 1/16W	R571	1-216-797-11	METAL CHIP	10 5% 1/16W
R516	1-216-845-11	METAL CHIP	100K 5% 1/16W	R572	1-216-825-11	METAL CHIP	2.2K 5% 1/16W
R517	1-216-825-11	METAL CHIP	2.2K 5% 1/16W	R573	1-216-825-11	METAL CHIP	2.2K 5% 1/16W
R518	1-216-825-11	METAL CHIP	2.2K 5% 1/16W	R574	1-216-825-11	METAL CHIP	2.2K 5% 1/16W
R519	1-216-841-11	METAL CHIP	47K 5% 1/16W	R575	1-216-825-11	METAL CHIP	2.2K 5% 1/16W
R520	1-216-825-11	METAL CHIP	2.2K 5% 1/16W	R576	1-216-841-11	METAL CHIP	47K 5% 1/16W
R521	1-216-825-11	METAL CHIP	2.2K 5% 1/16W	R577	1-216-797-11	METAL CHIP	10 5% 1/16W
R522	1-216-825-11	METAL CHIP	2.2K 5% 1/16W	R578	1-216-841-11	METAL CHIP	47K 5% 1/16W
R523	1-216-825-11	METAL CHIP	2.2K 5% 1/16W	R579	1-216-825-11	METAL CHIP	2.2K 5% 1/16W
R524	1-216-825-11	METAL CHIP	2.2K 5% 1/16W	R580	1-216-825-11	METAL CHIP	2.2K 5% 1/16W
R525	1-216-825-11	METAL CHIP	2.2K 5% 1/16W	R581	1-216-841-11	METAL CHIP	47K 5% 1/16W
R526	1-216-825-11	METAL CHIP	2.2K 5% 1/16W	R582	1-216-825-11	METAL CHIP	2.2K 5% 1/16W
R527	1-216-825-11	METAL CHIP	2.2K 5% 1/16W			< VIBRATOR >	
R528	1-216-857-11	METAL CHIP	1M 5% 1/16W	X501	1-781-210-21	VIBRATOR, CERAMIC (4MHz)	
R529	1-216-857-11	METAL CHIP	1M 5% 1/16W	X502	1-760-201-11	VIBRATOR, CRYSTAL (32.768kHz)	
R530	1-216-841-11	METAL CHIP	47K 5% 1/16W			*****	
R531	1-216-857-11	METAL CHIP	1M 5% 1/16W	*	1-666-723-11	REEL BOARD	
R532	1-216-841-11	METAL CHIP	47K 5% 1/16W			*****	
R533	1-216-841-11	METAL CHIP	47K 5% 1/16W			*****	
R534	1-216-857-11	METAL CHIP	1M 5% 1/16W	*	X-3377-112-1	ROM ASSY	
R535	1-216-845-11	METAL CHIP	100K 5% 1/16W			< CAPACITOR >	
R536	1-216-821-11	METAL CHIP	1K 5% 1/16W	C801	1-162-964-11	CERAMIC CHIP	0.001uF 10% 50V
R537	1-216-821-11	METAL CHIP	1K 5% 1/16W	C802	1-115-156-11	CERAMIC CHIP	1uF 10V
R538	1-216-821-11	METAL CHIP	1K 5% 1/16W	C803	1-162-927-11	CERAMIC CHIP	100PF 5% 50V
R539	1-216-821-11	METAL CHIP	1K 5% 1/16W	C804	1-162-927-11	CERAMIC CHIP	100PF 5% 50V
R540	1-216-825-11	METAL CHIP	2.2K 5% 1/16W	C805	1-162-927-11	CERAMIC CHIP	100PF 5% 50V
R541	1-216-821-11	METAL CHIP	1K 5% 1/16W			< TRANSISTOR >	
R542	1-216-825-11	METAL CHIP	2.2K 5% 1/16W	Q801	8-729-037-92	TRANSISTOR	2SD2216J-R(TX).SO
R543	1-216-825-11	METAL CHIP	2.2K 5% 1/16W	Q802	8-729-037-92	TRANSISTOR	2SD2216J-R(TX).SO
R544	1-216-825-11	METAL CHIP	2.2K 5% 1/16W			< RESISTOR >	
R545	1-216-825-11	METAL CHIP	2.2K 5% 1/16W	R801	1-216-825-11	METAL CHIP	2.2K 5% 1/16W
R546	1-216-825-11	METAL CHIP	2.2K 5% 1/16W	R802	1-216-825-11	METAL CHIP	2.2K 5% 1/16W
R547	1-216-825-11	METAL CHIP	2.2K 5% 1/16W	R803	1-216-825-11	METAL CHIP	2.2K 5% 1/16W
R548	1-216-825-11	METAL CHIP	2.2K 5% 1/16W	R804	1-216-825-11	METAL CHIP	2.2K 5% 1/16W
R549	1-216-833-11	METAL CHIP	10K 5% 1/16W	R805	1-216-797-11	METAL CHIP	10 5% 1/16W
R550	1-216-857-11	METAL CHIP	1M 5% 1/16W	R806	1-216-841-11	METAL CHIP	47K 5% 1/16W
R551	1-216-829-11	METAL CHIP	4.7K 5% 1/16W	R807	1-216-841-11	METAL CHIP	47K 5% 1/16W
R552	1-216-829-11	METAL CHIP	4.7K 5% 1/16W	R808	1-216-841-11	METAL CHIP	47K 5% 1/16W
R553	1-216-817-11	METAL CHIP	470 5% 1/16W	R809	1-216-845-11	METAL CHIP	100K 5% 1/16W
R554	1-216-833-11	METAL CHIP	10K 5% 1/16W	R810	1-216-845-11	METAL CHIP	100K 5% 1/16W
R555	1-216-797-11	METAL CHIP	10 5% 1/16W			*****	
R556	1-216-841-11	METAL CHIP	47K 5% 1/16W			MISCELLANEOUS	
R557	1-216-833-11	METAL CHIP	10K 5% 1/16W			*****	
R558	1-216-833-11	METAL CHIP	10K 5% 1/16W	18	1-672-548-11	FLEXIBLE BOARD	
R559	1-216-845-11	METAL CHIP	100K 5% 1/16W	19	1-694-492-11	CONDUCTIVE BOARD, CONNECTION(B)	
R560	1-216-845-11	METAL CHIP	100K 5% 1/16W				
R561	1-216-845-11	METAL CHIP	100K 5% 1/16W				
R562	1-216-825-11	METAL CHIP	2.2K 5% 1/16W				
R563	1-216-825-11	METAL CHIP	2.2K 5% 1/16W				
R564	1-216-841-11	METAL CHIP	47K 5% 1/16W				
R565	1-216-841-11	METAL CHIP	47K 5% 1/16W				

Ref. No.	Part No.	Description	Remark
20	1-694-491-11	CONDUCTIVE BOARD,CONNECTION(A)	
52	1-672-549-11	FLEXIBLE BOARD	
ANT101	1-501-657-22	FERRITE-ROD ANTENNA (MW/LW)	
ANT102	1-501-658-11	ANTENNA, TELESCOPIC (FM/SW)	
EL501	1-803-372-11	ELEMENT, EL INDICATION(LCD BACK LIGHT)	
LCD501	1-803-371-11	PANEL, LIQUID CRYSTAL DISPLAY	
P902	1-790-234-11	CODE (WITH PLUG)	
SP301	1-505-165-11	SPEAKER (4cm)	

ACCESSORIES & PACKING MATERIALS

△	1-467-543-11	ADAPTOR, AC (AC-E311) (AEP,Singapore)
△	1-467-543-21	ADAPTOR, AC (AC-E312) (US)
△	1-467-543-31	ADAPTOR, AC (AC-E313) (Tourist)
△	1-467-543-41	ADAPTOR, AC (AC-E314) (Canadian)
△	1-569-007-11	ADAPTOR, CONVERSION 2P (Tourist)
△	1-569-008-21	ADAPTOR, CONVERSION 2P (AEP,Singapore)
△	1-573-856-11	ADAPTOR, CHANGE (Canadian)
	3-015-932-01	CASE, CARRYING (FOR LOOP ANTENNA)
	3-031-532-01	CASE, CARRYING (FOR RADIO)
	3-865-472-01	MANUAL, INSTRUCTION (JAPANESE, ENGLISH, SPANISH,KOREAN, CHINESE) (7AEP, Singapore, Tourist)
	3-865-472-11	MANUAL, INSTRUCTION (GERMAN, DUTCH, PORTUGUESE,SWEDISH, ITALIAN) (AEP)
	3-865-472-21	MANUAL, INSTRUCTION (ENGLISH, FRENCH, SPANISH,DANISH, FINNISH) (US,Canadian,AEP)
	3-893-802-14	BOOK, GUIDE, WAVE
	8-953-130-90	HEADPHONE MDR-E805LP/K SET
	X-332-965-71	ATTACHMENT

The components identified by mark △ or dotted line with mark △ are critical for safety. Replace only with part number specified.	Les composants identifiés par une marque △ sont critiques pour la sécurité. Ne les remplacer que par une pièce portant le numéro spécifié.
--	--